

GRADUA: INGENIARITZA MEKANIKOA
GRADU AMAIERAKO LANA

***PNEUMATIKOEN ERRODADURA
SAIAKUNTZA BANKUA***

4.DOKUMENTUA – PLANOAK

Ikaslea: Padrones Ligerio, Julen

Zuzendaria: Abasolo Bilbao, Mikel

Ikasturtea: 2018-2019

Data: Bilbo, 2018ko azaroaren 8a

4.DOKUMENTUA: PLANOAK

MULTZO OSOA.....	P01
ABIADURA ESTAZIOA AZPIMULTZOA.....	P02
DANBORRAREN ARDATZA ETA PLAKA DOITZAILEA.....	P03
KARRO MUGIKORRAREN ERAGINGAILUAREN AZPIMULTZOA.....	P04
ERAGINGAILU LINEALAREN MUTURRA.....	P05
BESO OSZILAKORRAREN AZPIMULTZOA.....	P06
ERAZTUNAK.....	P07
BERMAPUNTUAREN ARDATZA.....	P08
GURPILAREN ARDATZA.....	P09
ESTALKIAK.....	P10
PALANKA BESO SOLDATUA.....	P11

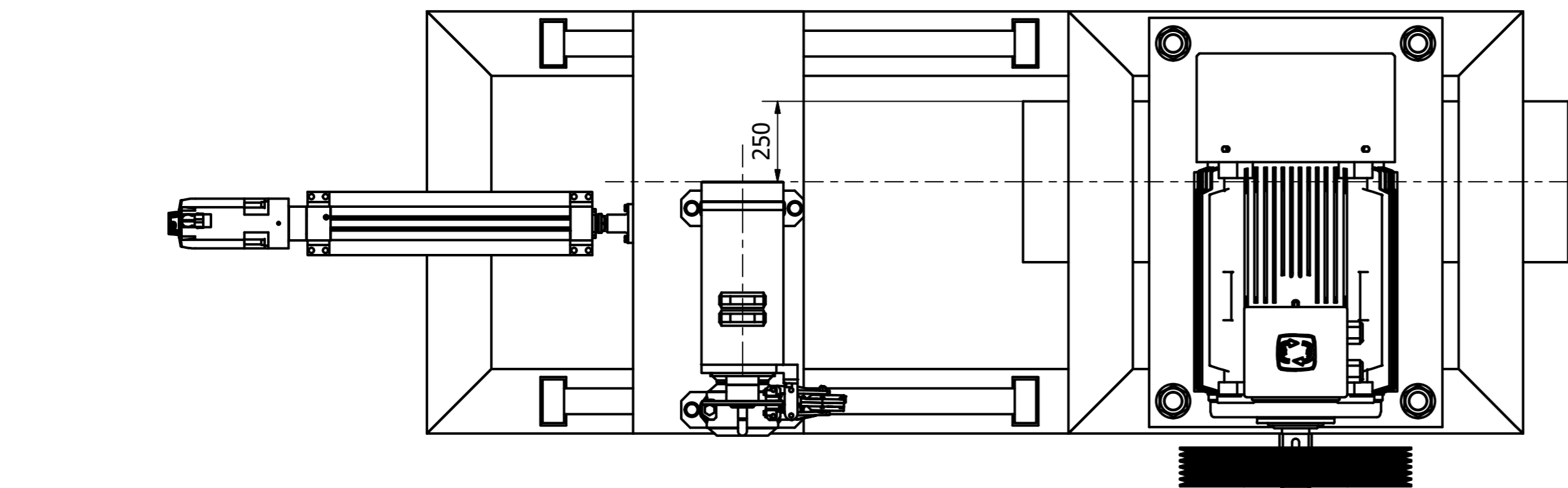
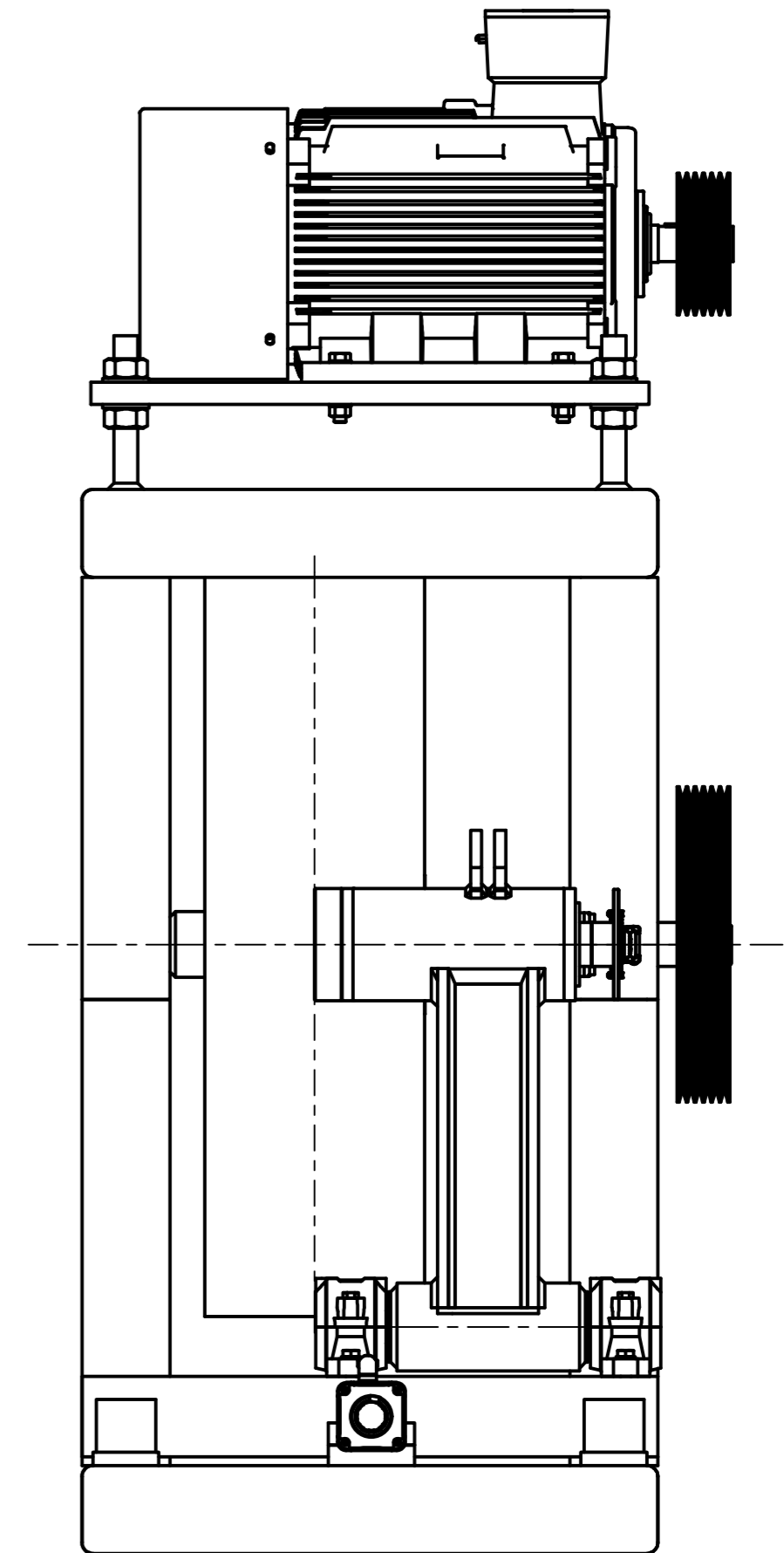
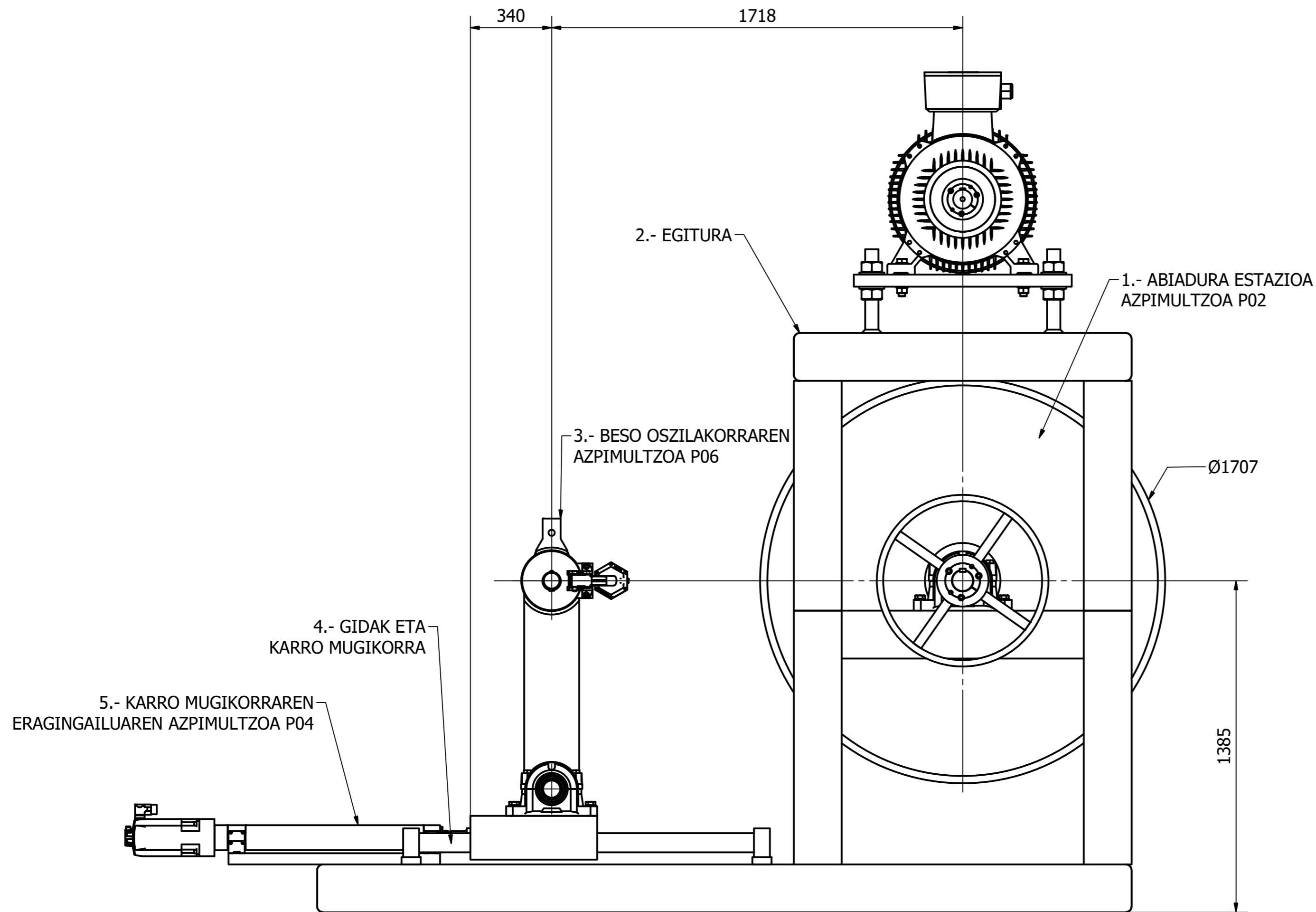

PLANOETAN EZ DIRA UHALAK ERAKUSTEN

1	ABIADURA ESTAZIOA AZPIMULTZOA	P02			
2	EGITURA	-			
3	BESO OSZILAKORRAREN AZPIMULTZOA	P06			
4	GIDAK ETA KARRO MUGIKORRA	-			
5	KARRO MUGIKORRAREN ERAGINGAILUAREN AZPIMULTZOA	P04			
Marka	Kant.	Izendapena	Araudia/Planoa	Materiala	Pisua

	Data	Izen-Abizenak	Sinaturak		
Marratzua :	29/10/2018	Julen Padrones Ligeru			
Gainbegiratua :					
Homologatua :					

 Perdoi Orok. ISO 2768-m	Eskala 1:15	<h1>MULTZO OSOA</h1>	PNEUMATIKOEN ERRODADURA SAIAKUNTZA BANKUA
			Plano Zkia. : P01 Plano Kop. : 1 / 11



BILBOKO INGENIARITZA ESCOLA
ESCUELA DE INGENIERIA DE BILBAO

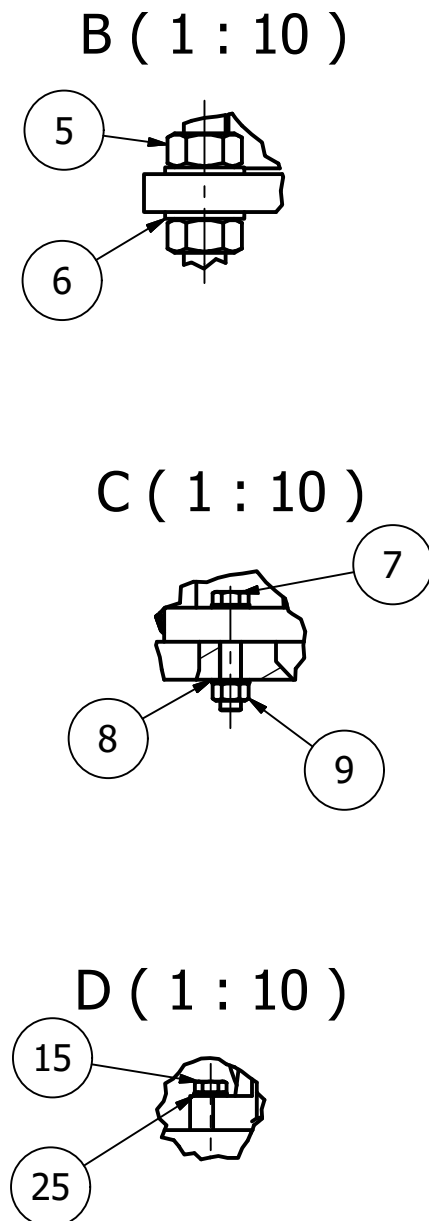
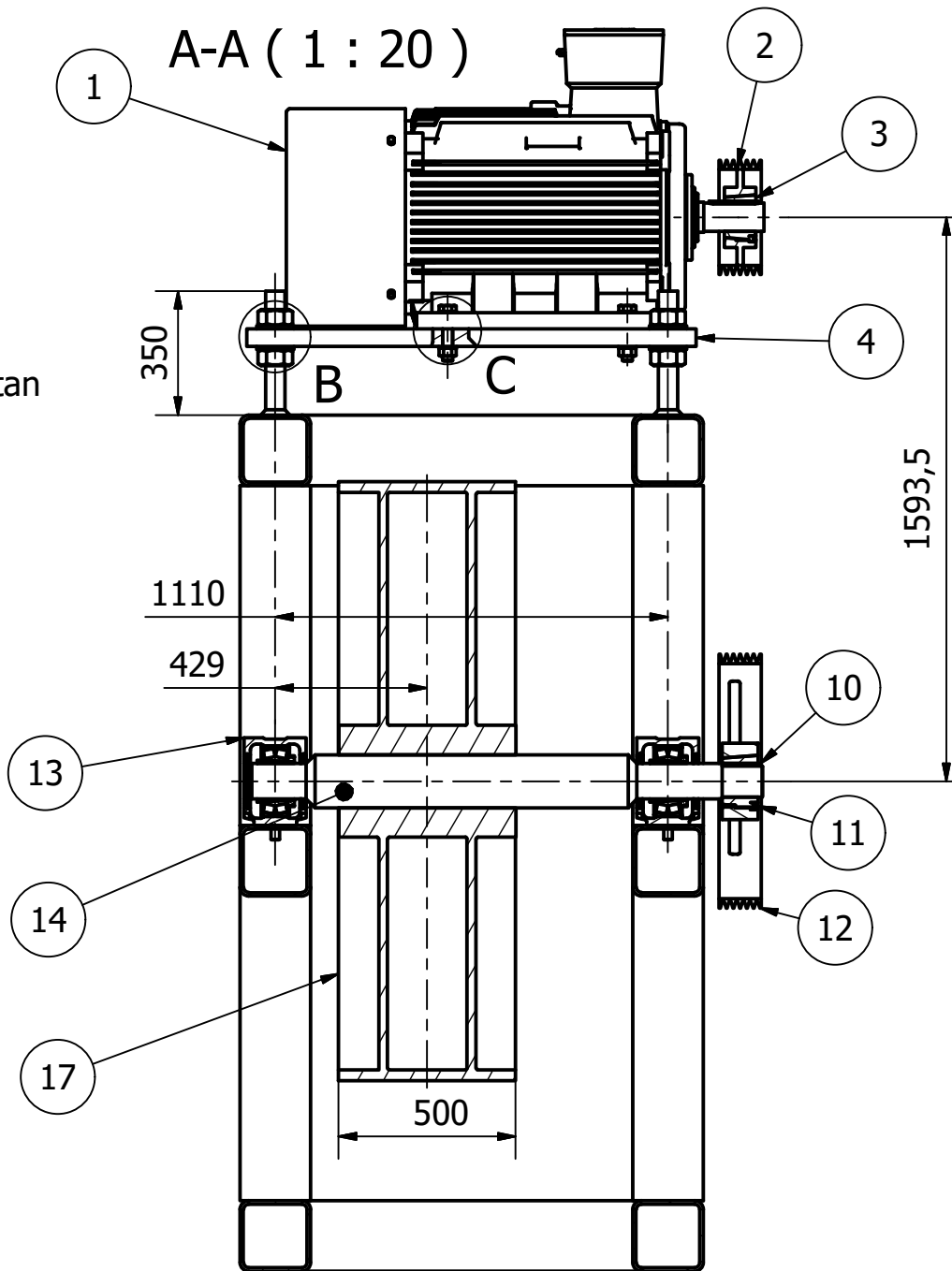
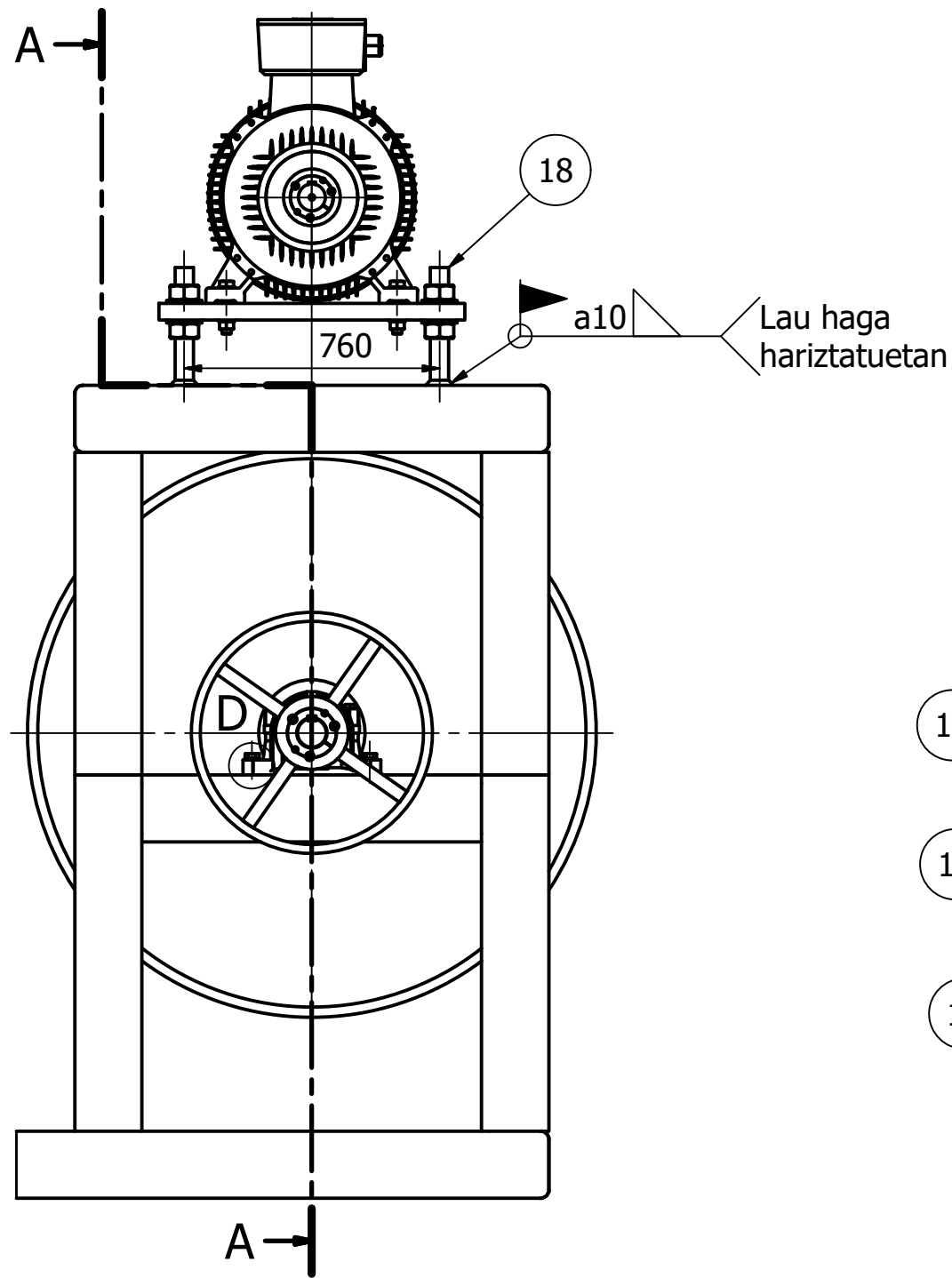

6	8	Zirindola	DIN 125 - 1 A A 57	Komertziala	0.431 kg
7	4	Torlojua	ISO 4016 - M27 x 140	Komertziala	0.822 kg
8	8	Zirindola	ISO 7089 - 27 - 140 HV	Komertziala	0.043 kg
9	4	Azkoina	ISO 4032 - M27	Komertziala	0.182 kg
10	1	Txabeta	DIN 6885-1 B B 25 x 14 x 110	Komertziala	0.882 kg
11	1	Zorro konikoa "Taper"	44104545-090	Komertziala	9.99 kg
12	1	Polea handia	4500b071006t5	Komertziala	69 kg
13	2	Errodamendu euskarria eta errodamendua	SNV 200 - 23222ESK.TVPB	Komertziala	21 kg
14	1	Danborraren ardatza	P03	AISI 4340	157.573 kg
15	4	Torlojua	DIN 933 - M24 x 90	Komertziala	0.445 kg
16	4	Zirindola	ISO 7089 - 24 - 140 HV	Komertziala	0.006 kg
17	1	Danborra	-	-	1600 kg
18	4	Haga hariztatua	DIN 975 - M56	Komertziala	6.545 kg
Marka	Kant.	Izendapena	Aradua/Planoa	Materiala	Pisua

1	1	Motorea	M2QA 31554A 3GQA 312	Komertziala	900 kg
2	1	Polea txikia	4500b031506t6	Komertziala	25.1 kg
3	1	Zorro konikoa "Taper"	44103535-080	Komertziala	4.08 kg
4	1	Plaka doitzalea	P03	ST 37-2	57.133 kg
5	8	Azkoina	ISO 4032 - M56	Komertziala	1.451 kg
Marka	Kant.	Izendapena	Aradua/Planoa	Materiala	Pisua
Marraztua :		Data	Izen-Abizenak	Sinadurak	
Gainbegiratua :		29/10/2018	Julen Padrones Ligerio		
Homologatua :					
Eskala		1:20		PNEUMATIKOEN ERRODADURA SAIKUNTZA BANKUA	
Perdoi Orok.		ISO 2768-m		Plano Zkia. : P02	
ABIADURA ESTAZIOA AZPIMULTZOA				Plano Kop. : 2 / 11	



14.- N9 / (N7 /)
E (1:4)

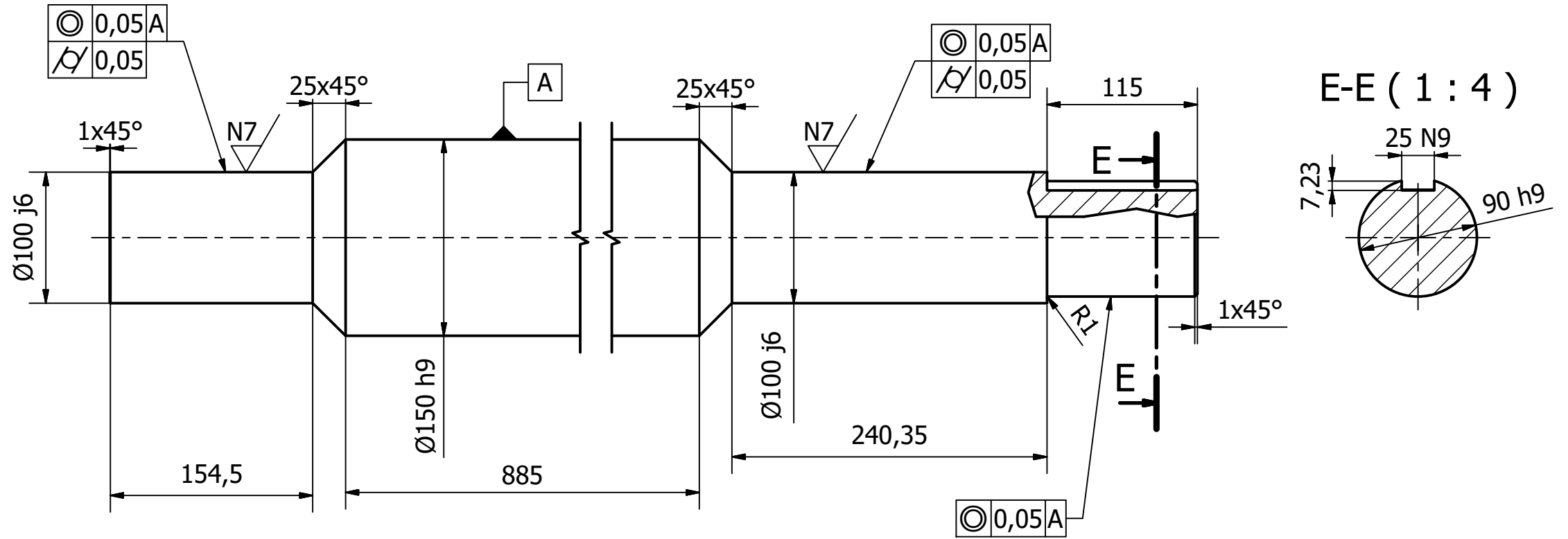

4.- N9 / E (1:10)

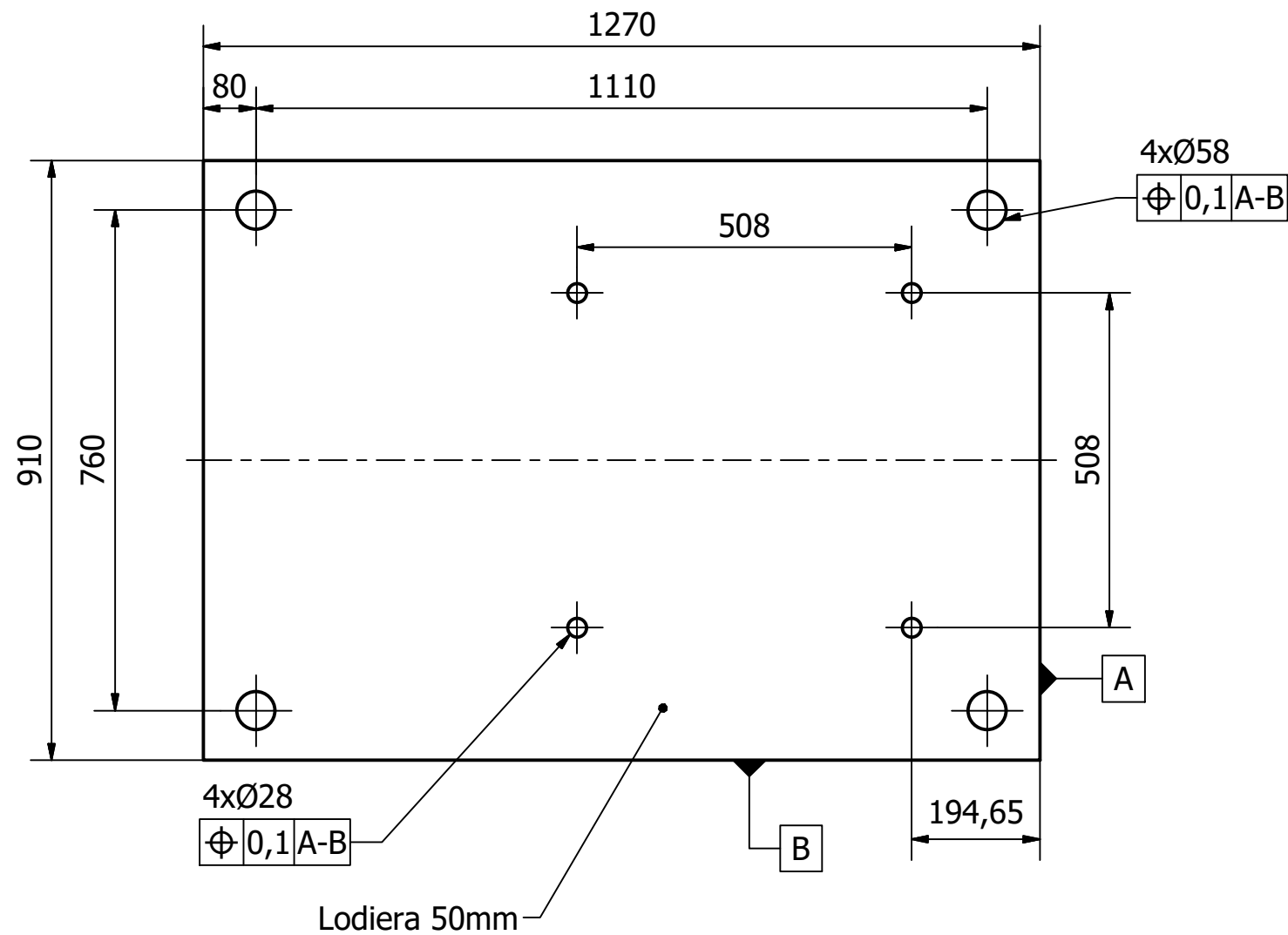

14	1	Danberraren ardatza	P03	AISI 4340	157.573 kg
4	1	Plaka doitzaila	P03	ST 37 - 2	57.133 kg
Marka	Kant.	Izendapena	Arudia/Planoa	Materiala	Pisua
Marrastua :		Data	Izen-Abizenak	Sinadurak	
Gainbegiratua :		29/10/2018	Julen Padrones Ligerio		
Homologatua :					
Perdoi Orok.		Eskala		 BILBOKO INGENIARITZA ESKOLA ESCUELA DE INGENIERIA DE BILBAO	
ISO 2768-m		1:4 1:10			
DANBERRAREN ARDATZA ETA PLAKA DOITZAILA				PNEUMATIKOEN ERRODADURA SAIKUNTZA BANKUA	
				Plano Zkia. : P03	
				Plano Kop. : 3 / 11	

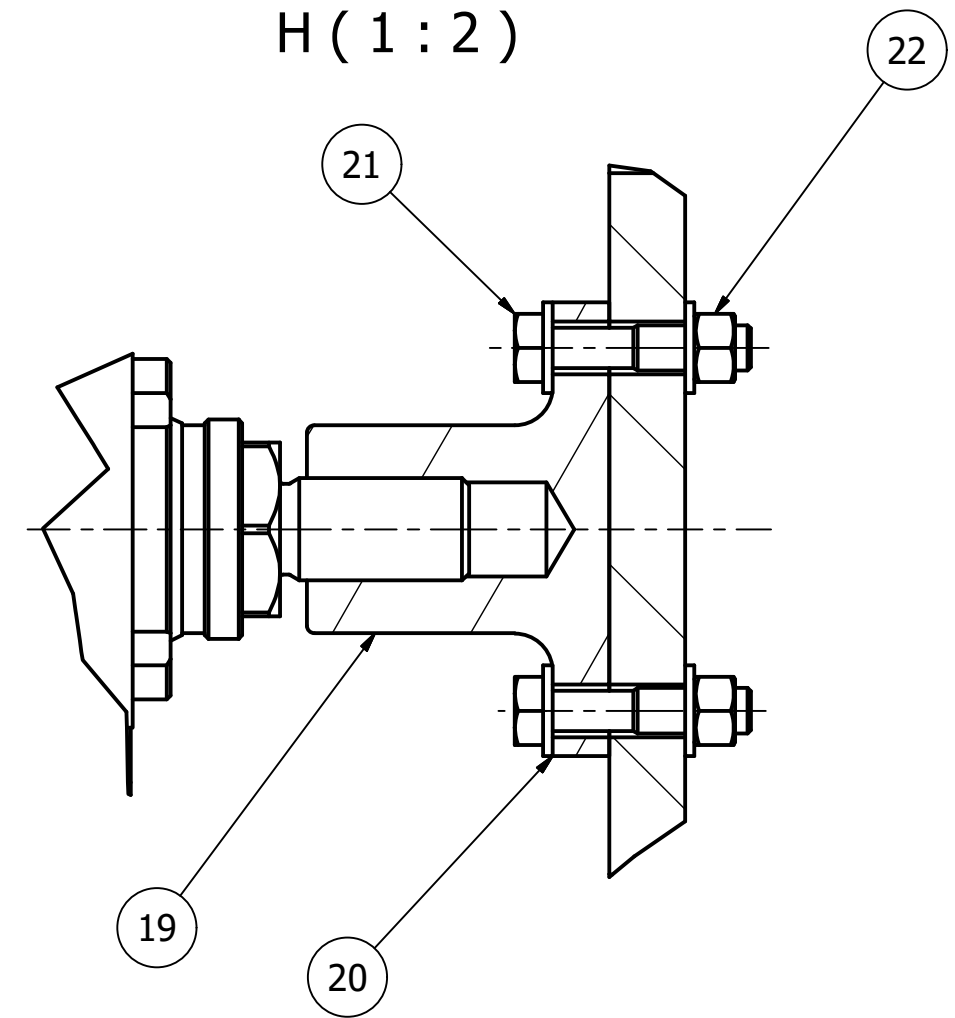
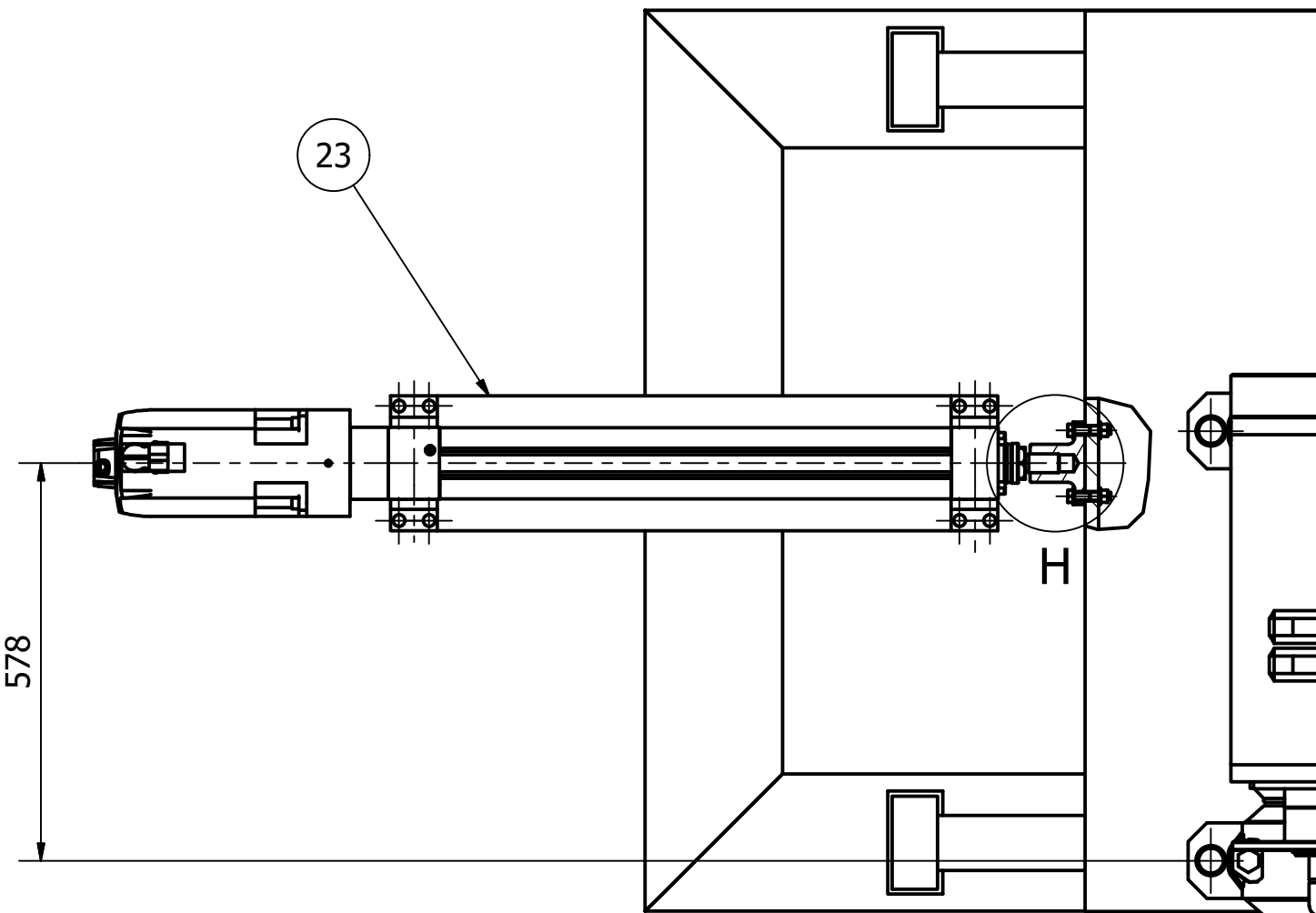
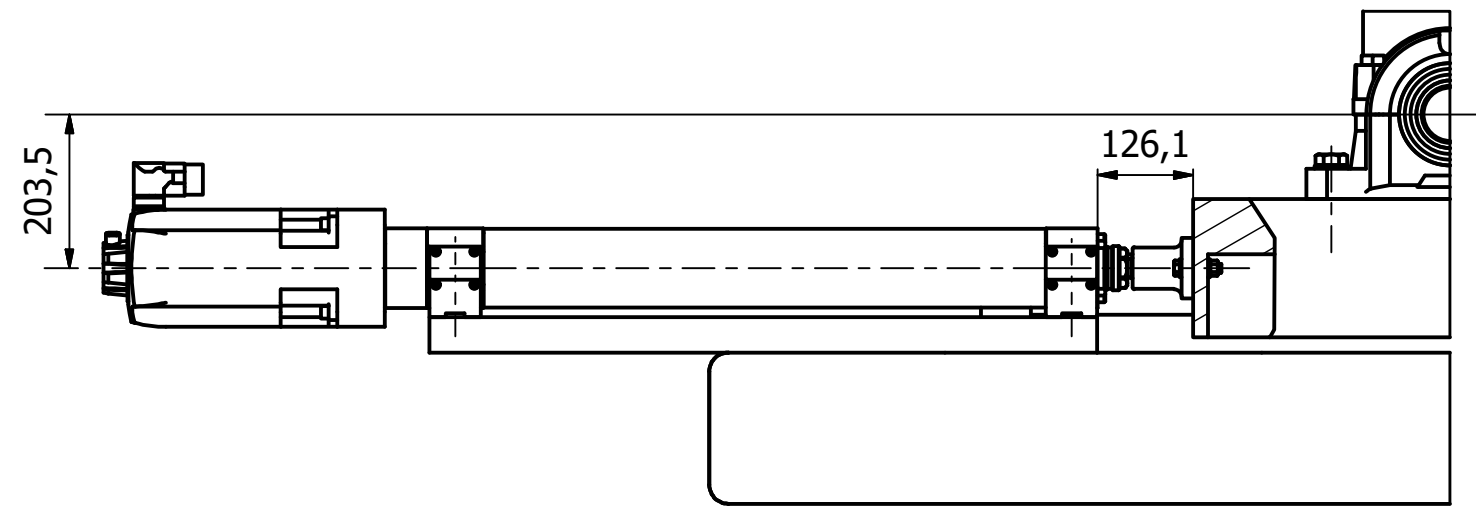

19	1	Eragingailu linealaren muturra	P05	AISI 4340	0.265 kg
20	4	Zirindola	ISO 7089 - 12 - 140 HV	Komertziala	0.006 kg
21	2	Torlojua	ISO 4015 - M12 x 55	Komertziala	0.058 kg
22	2	Azkoina	ISO 4032 - M12	Komertziala	0.016 kg
23	1	Eragingailu lineala	CASM - 100 - BA - 0600 - AADB1DA - AA0000 - GI - AAA - 00 - MS - OB - A13 - AA	Komertziala	18.027 kg

Marka	Kant.	Izendapena	Araudia/Planoa	Materiala	Pisua
-------	-------	------------	----------------	-----------	-------

		Data	Izen-Abizenak	Sinadurak		
Marraztua :		29/10/2018	Julen Padrones Ligerio			
Gainbegiratua :						
Homologatua :						

	Eskala	KARRO MUGIKORRAREN ERAGINGAILUAREN AZPIMULTZOA	PNEUMATIKOEN ERRODADURA SAIAKUNTZA BANKUA
	Perdoi Orok.		Plano Zkia. : P04
	ISO 2768-m		1:10

19.- $\nabla N9 / (\nabla N7 /)$

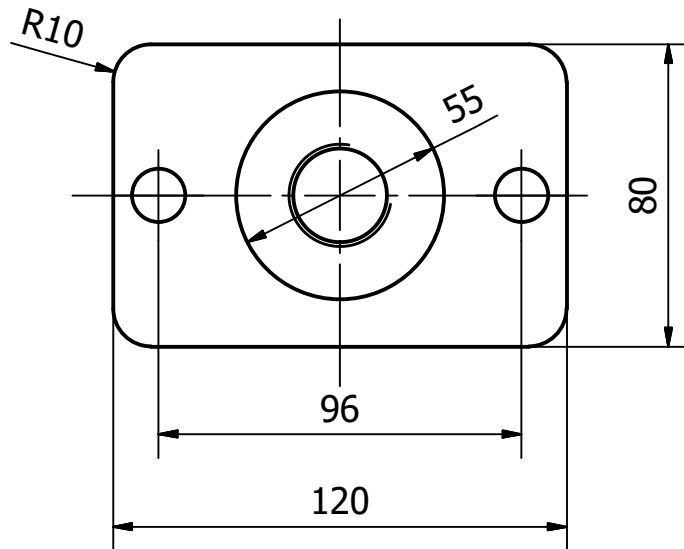
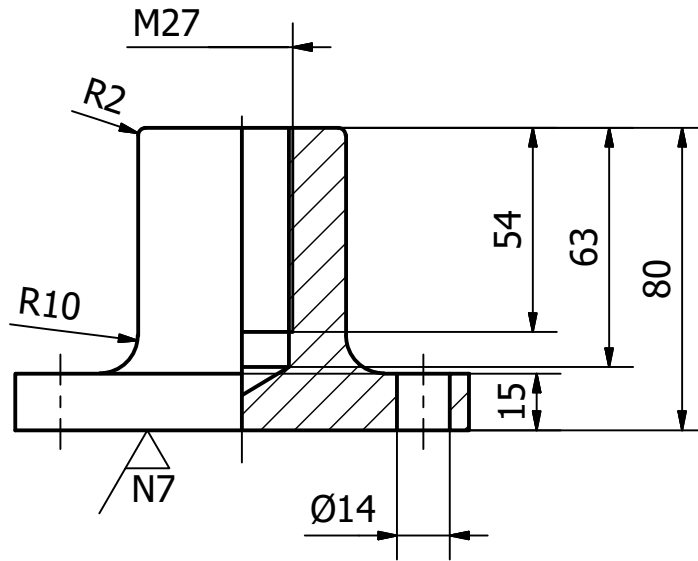

Akotatu gabeko erradioak R=2mm

19	1	Eragingailu linealaren muturra	P05	AISI 4340	0.265 kg
Marka	Kant.	Izendapena	Araudia/Planoa	Materiala	Pisua
Marrastua :		Data	Izen-Abizenak	Sinadurak	
Gainbegiratua :		29/10/2018	Julen Padrones Ligerio	 BILBOKO INGENIARITZA ESKOLA ESCUELA DE INGENIERÍA DE BILBAO	
Homologatua :					
Eskala					
Perdoi Orok.	1:2	ERAGINGAILU LINEALAREN MUTURRA		PNEUMATIKOEN ERRODADURA SAIAKUNTZA BANKUA	
ISO 2768-m				Plano Zkia. : P05	
				Plano Kop. : 5 / 11	

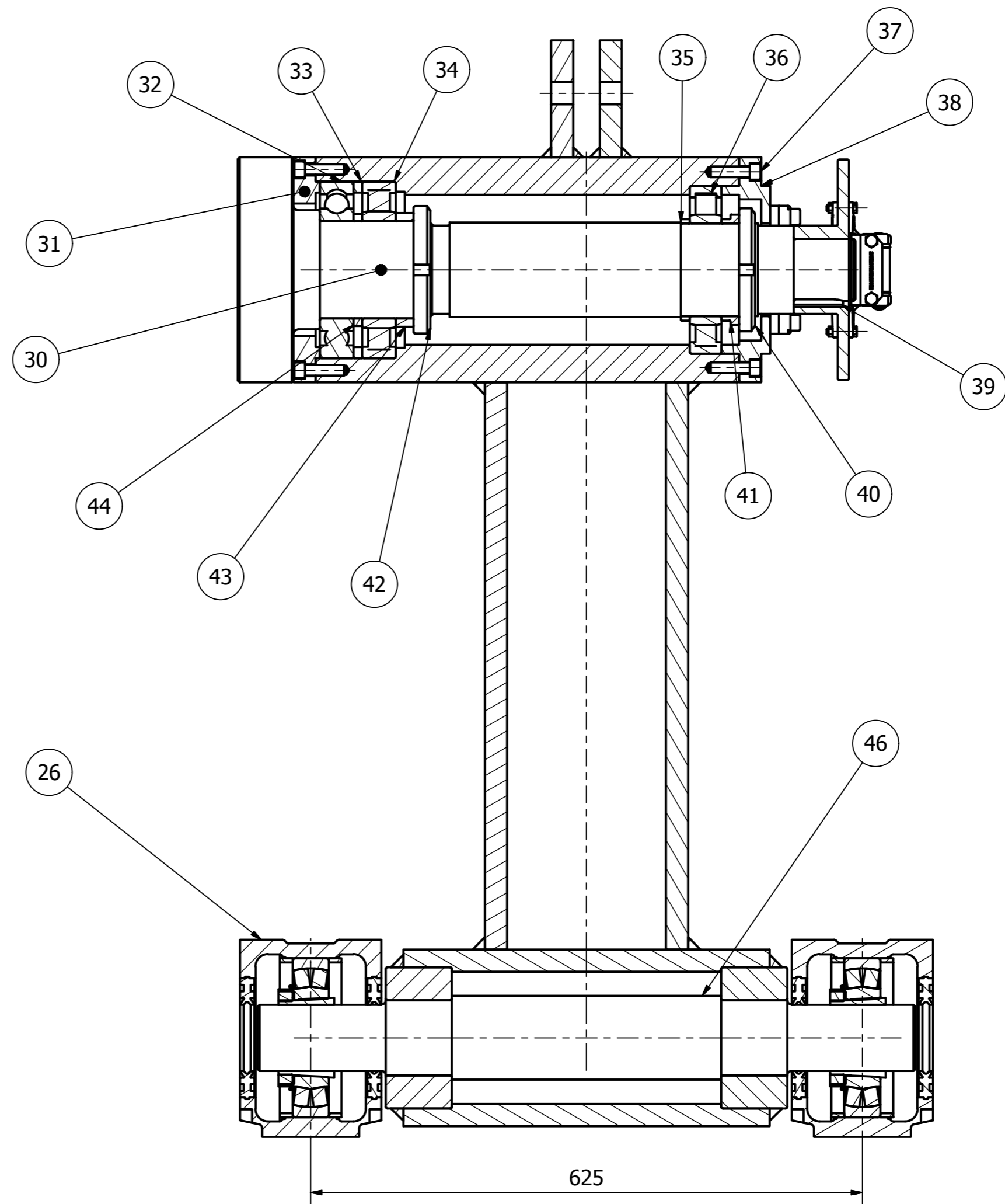
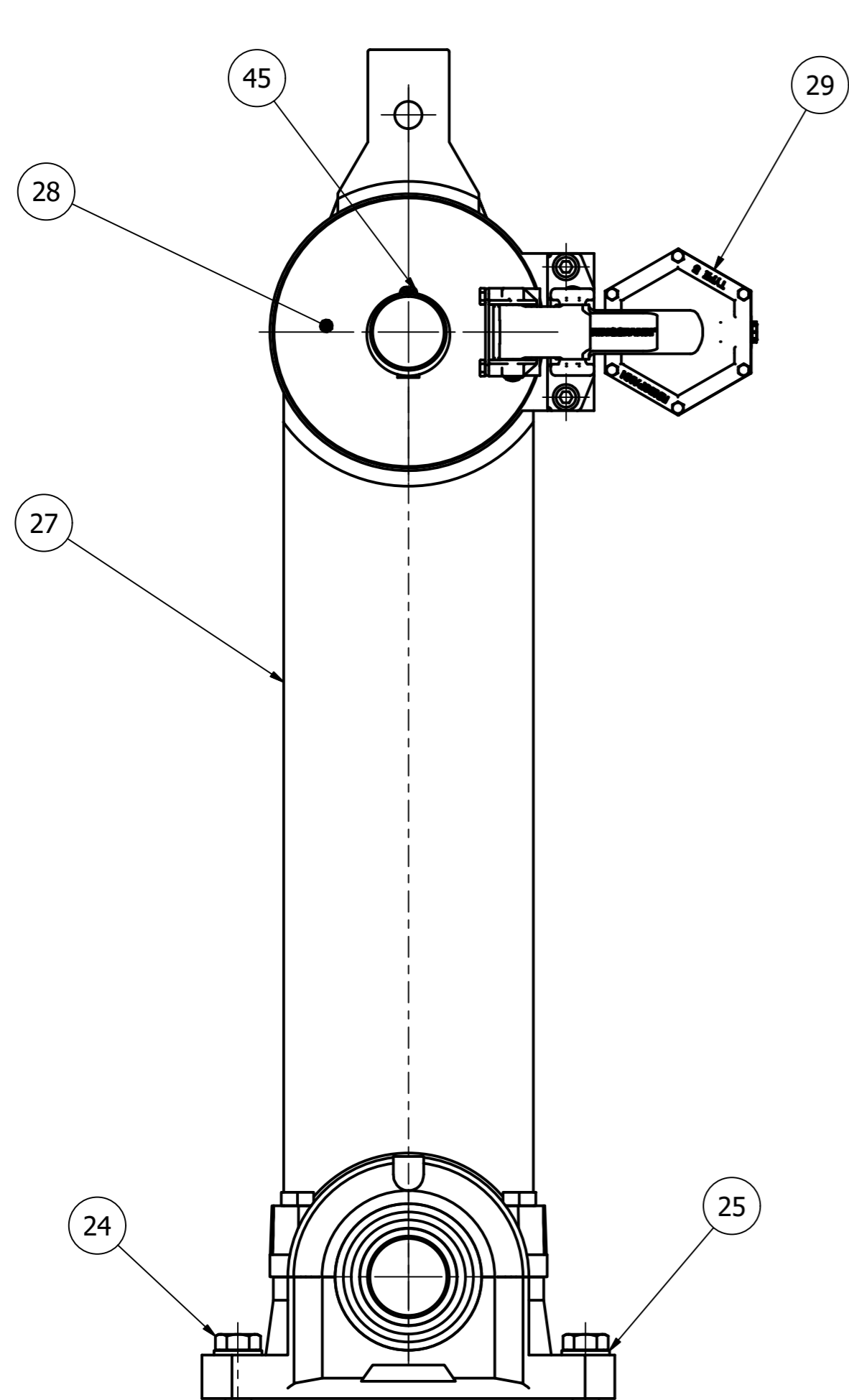

33	1	Eraztuna 1	P07	F 1140	0.073 kg
34	1	Errodamendua	SKF NUNU 222 EC	Komertziala	4.7 kg
35	1	Eraztuna 4	P07	F 1140	0.017 kg
36	1	Errodamendua	SKF NUNU 221 EC	Komertziala	3.95 kg
37	14	Torlojua	DIN 912 - M12 x 1.5 x 45	Komertziala	0.059 kg
38	1	Tapa 2	P10	F 1140	1.352 kg
39	1	Txabeta	DIN 6885-1 A A 20 x12 x 56	Komertziala	0.11 kg
40	1	Segurtasun azkoina	DIN 981 KM 21	Komertziala	0.845 kg
41	1	Eraztuna 5	P07	F 1140	0.053 kg
42	1	Segurtasun azkoina	DIN 981 KM 22	Komertziala	0.965 kg
43	1	Eraztuna 3	P07	F 1140	0.071 kg
44	1	Eraztuna 2	P07	F 1140	0.031 kg
45	1	Segurtasun eraztuna	DIN 471 70x2.5	Komertziala	0.085 kg
46	1	Bermapuntuaren ardatza	P08	AISI 4340	33.727 kg
Marka	Kant.	Izendapena	Araudia/Planoa	Materiala	Pisua

24	4	Torlojua	DIN 931 - 1 M24 x 95	Komertziala	0.121 kg
25	4	Zirindola	ISO 7089 24 -140 HV	Komertziala	0.010 kg
26	2	Errodamendu euskarria eta errodamendua	SNV 180 21317 - E1K.TVPB	Komertziala	10.037 kg
27	1	Palanka beso soldatua	P11	F 1140	172.82 kg
28	1	Balazta diskoa	BB 0250/12 -070 B	Komertziala	5.1 kg
29	1	Balazta	DV 020 PFK	Komertziala	6.38 kg
30	1	Gurpilaren ardatza	P09	AISI 4340	82.596 kg
31	1	Tapa 1	P10	F 1140	0.837 kg
32	1	Errodamendua	SKF 2Z6222-2Z	Komertziala	4.45 kg
Marka	Kant.	Izendapena	Araudia/Planoa	Materiala	Pisua

Marraztua :		Data	Izen-Abizenak	Sinadurak	
Gainbegiratua :		29/10/2018	Julen Padrones Ligerio		
Homologatua :					
Eskala		1:5			BESO OSZILAKORRAREN AZPIMULTZOA PNEUMATIKOEN ERRODADURA SAIKUNTZA BANKUA Plano Zkia. : P06 Plano Kop. : 6 / 11
Perdoi Orok.		ISO 2768-m			
ISO 2768-m					

33.- ∇ N9 / (∇ N7)

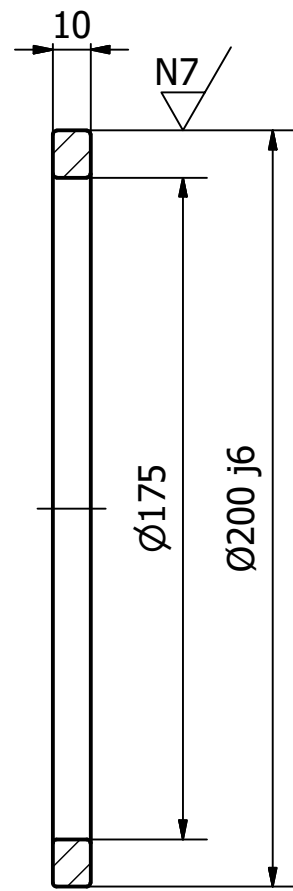

43.- ∇ N9 / (∇ N7)

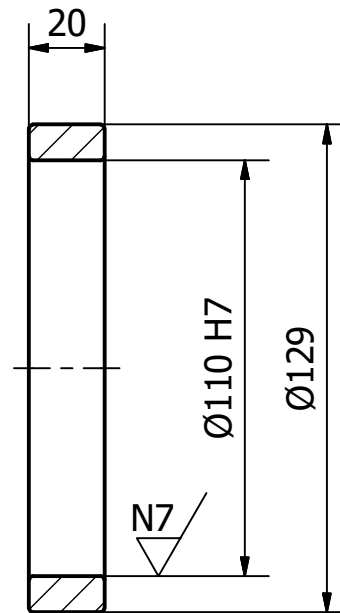

41.- ∇ N9 / (∇ N7)

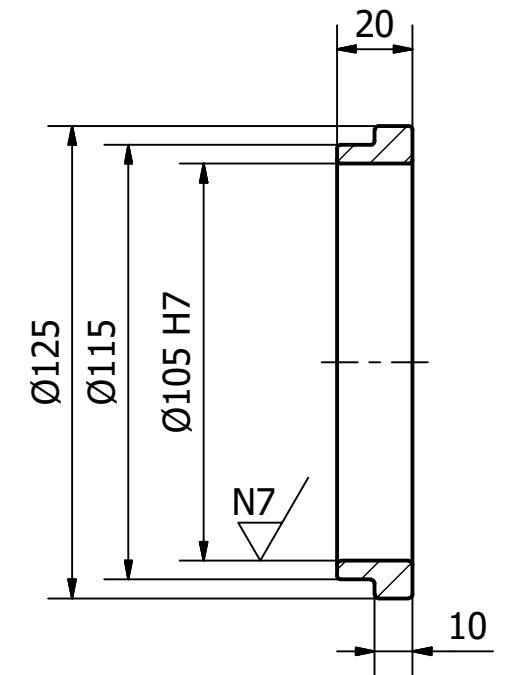

35.- ∇ N9 / (∇ N7)

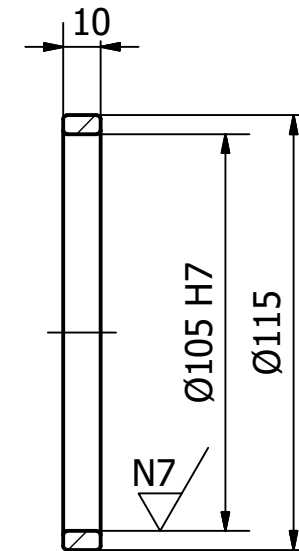

44.- ∇ N9 / (∇ N7)

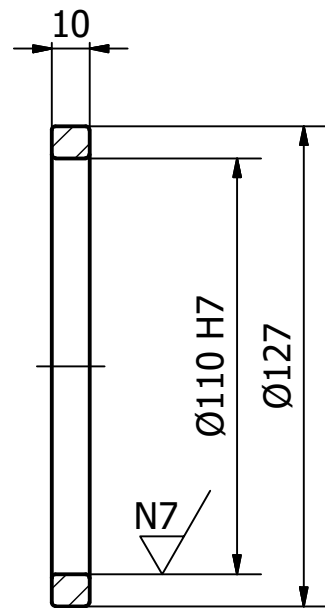

Akotatu gabeko
erradioak R=1mm

33	1	Eraztuna 1	P07	F 1140	0.073 kg
44	1	Eraztuna 2	P07	F 1140	0.031 kg
43	1	Eraztuna 3	P07	F 1140	0.071 kg
35	1	Eraztuna 4	P07	F 1140	0.017 kg
41	1	Eraztuna 5	P07	F 1140	0.053 kg

Marka	Kant.	Izendapena		Araudia/Planoa	Materiala	Pisua	
		Data	Izen-Abizenak	Sinadurak			
Marraztua :		29/10/2018	Julen Padrones Ligerio				
Gainbegiratua :							
Homologatua :							
	Eskala	ERAZTUNAK			PNEUMATIKOEN ERRODADURA SAIKUNTZA BANKUA		
Perdoi Orok.	1:2				Plano Zkia. :	P07	
ISO 2768-m					Plano Kop. :	7 / 11	

46.- ∇_{N9} / (∇_{N7})

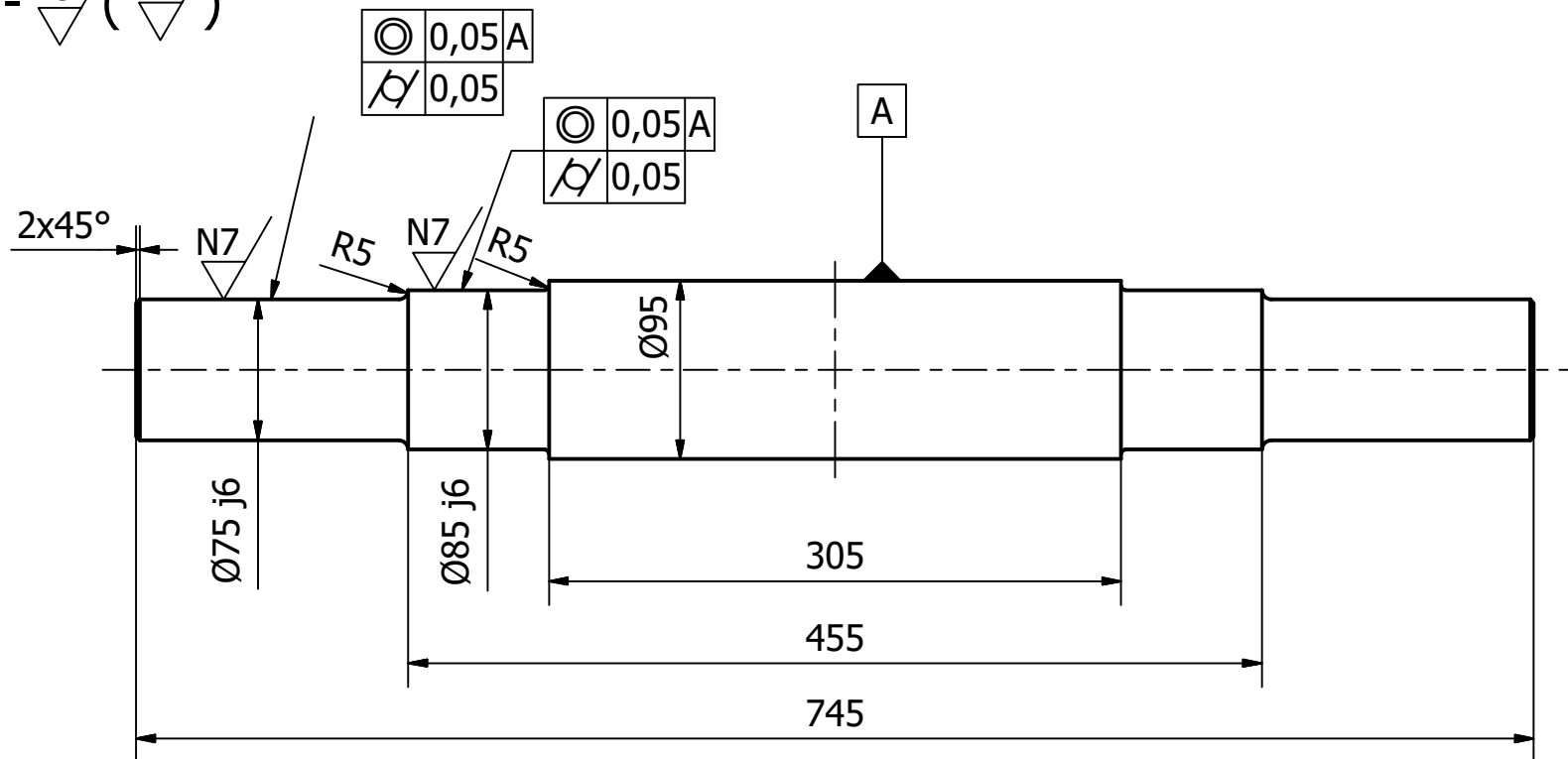

46	1	Bermapuntuaren ardatza	P08	AISI 4340	33.727 kg
Marka	Kant.	Izendapena	Araudia/Planoa	Materiala	Pisua
		Data	Izen-Abizenak	Sinadurak	
Marraztua :		29/10/2018	Julen Padrones Ligero		
Gainbegiratua :					
Homologatua :					
	Eskala	BERMAPUNTUAREN ARDATZA			PNEUMATIKOEN ERRODADURA SAIAKUNTZA BANKUA
Perdoi Orok.	1:4				Plano Zkia. : P08
ISO 2768-m					Plano Kop. : 8 / 11



30.- ∇_{N9} / (∇_{N7})

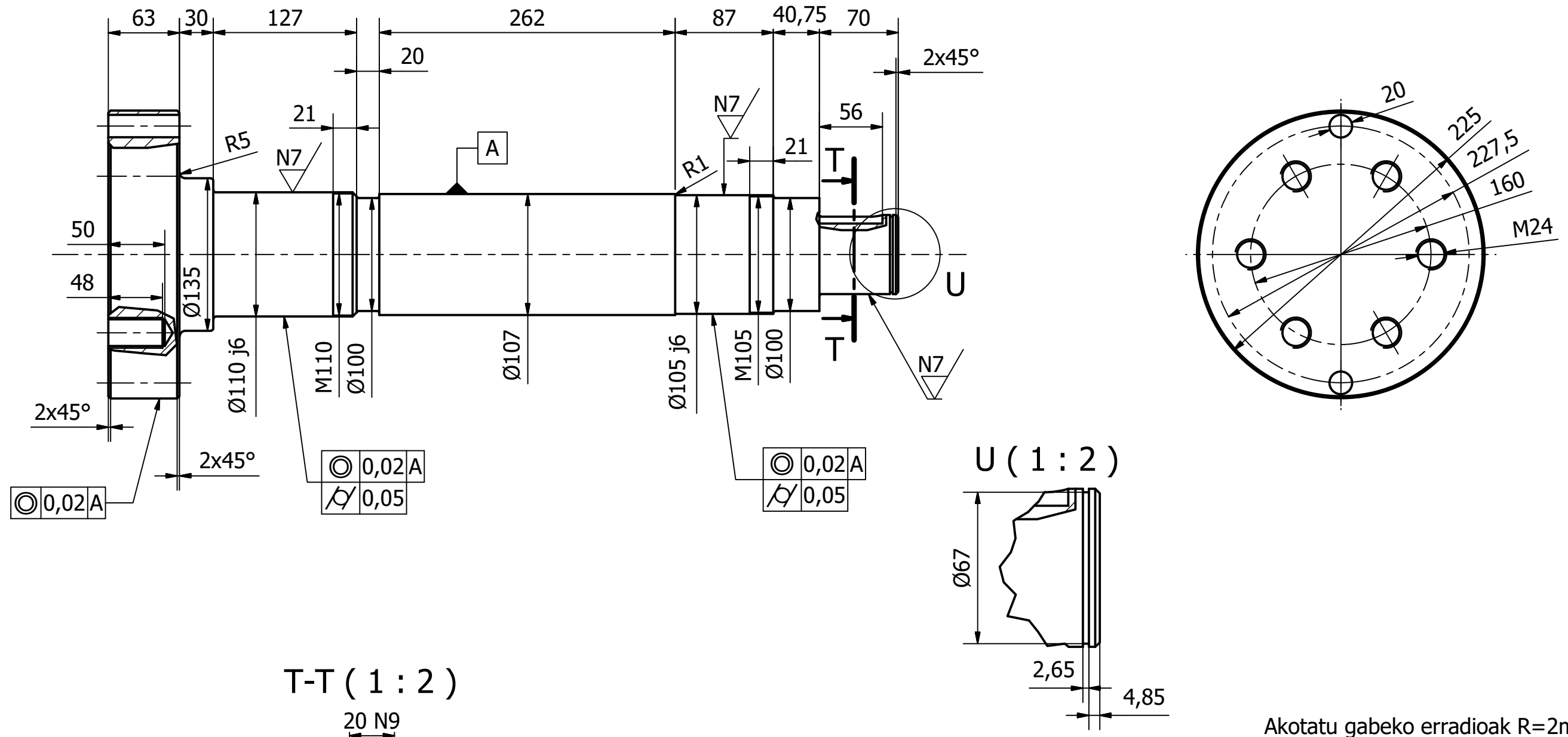

Akotatu gabeko erradioak R=2mm

30	1	Gurpilaren ardatza	P09	AISI 4340	66.880 kg
Marka	Kant.	Izendapena	Araudia/Planoa	Materiala	Pisua
Marraztua :		Data	Izen-Abizenak	Sinadurak	
Gainbegiratua :		29/10/2018	Julen Padrones Ligerio		
Homologatua :					
	Perdoi Orok.	Eskala	GURPILAREN ARDATZA		PNEUMATIKOEN ERRODADURA SAIKUNTZA BANKUA
		1:4			Plano Zkia. : P09
					Plano Kop. : 9 / 11

38.- $\nabla_{N9} / (\nabla_{N7})$

V-V (1:3)

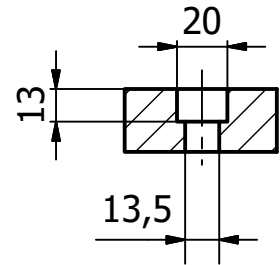

W-W (1:3)

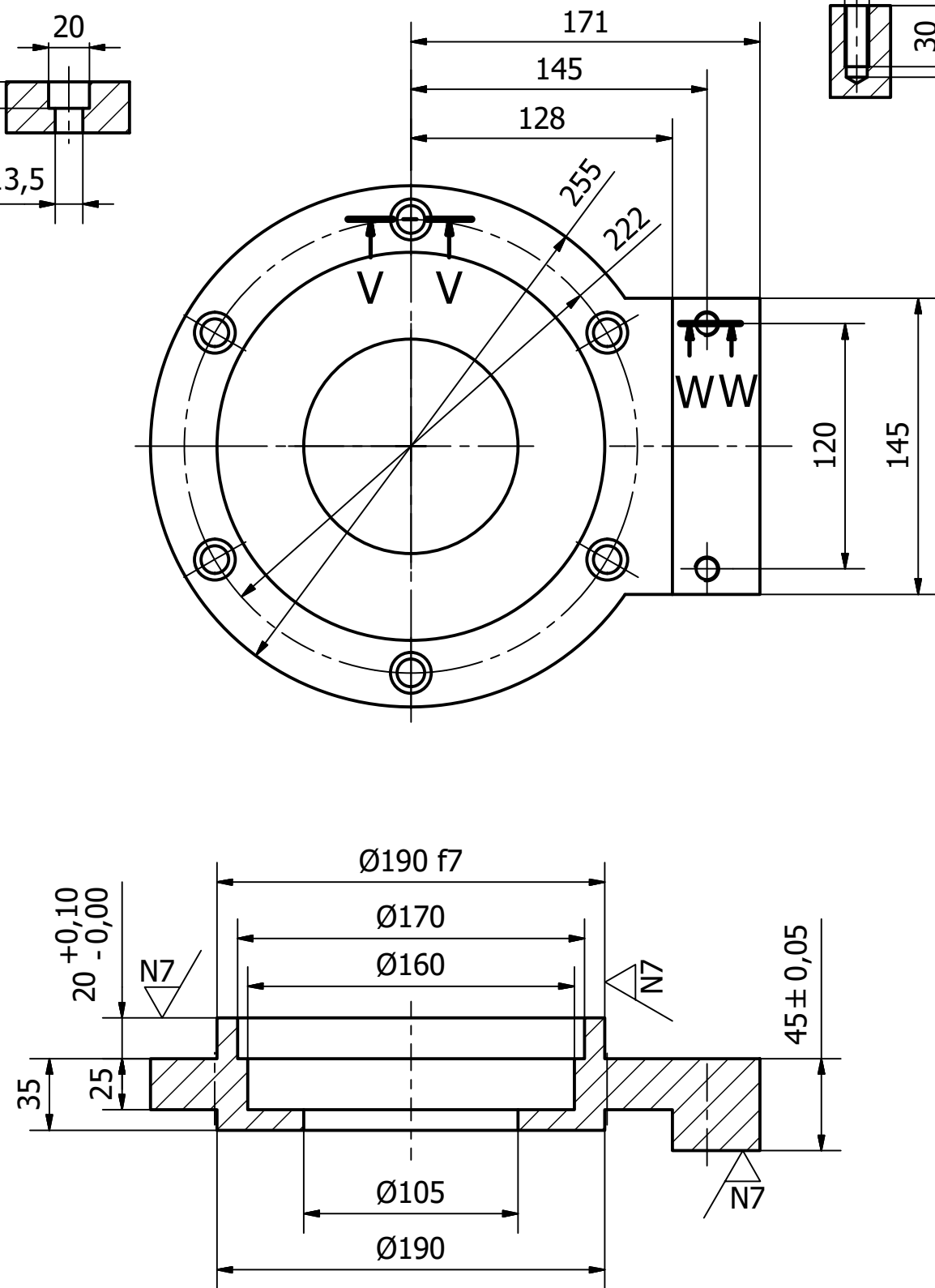
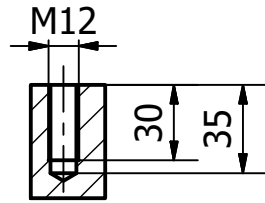

31.- $\nabla_{N9} / (\nabla_{N7})$

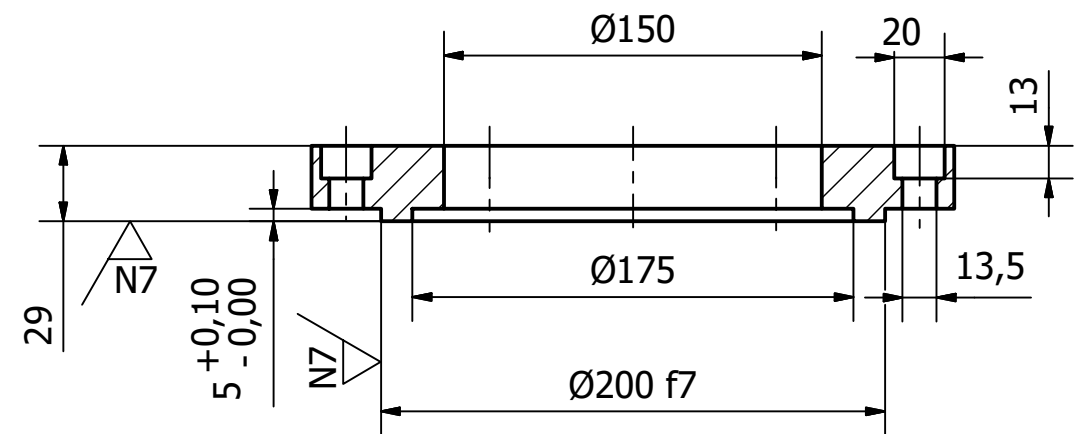
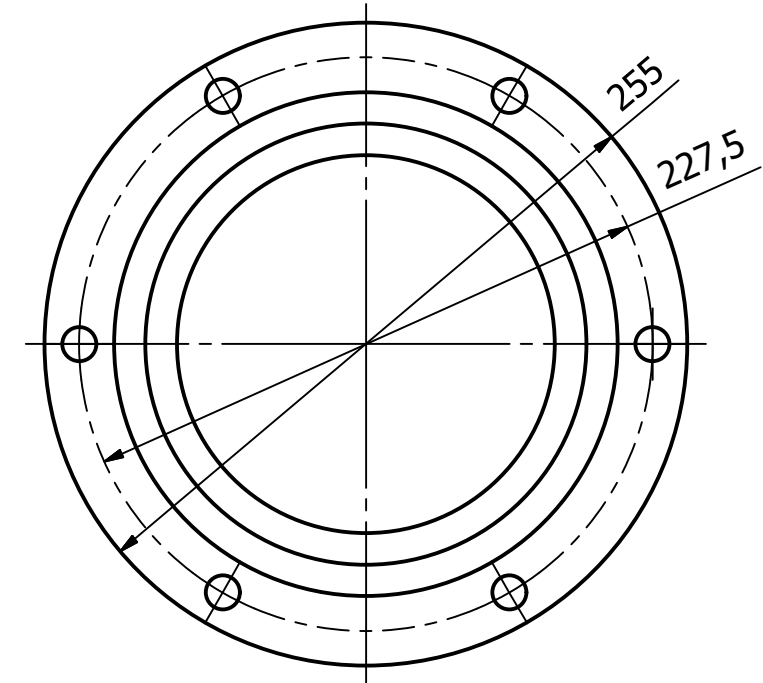

Akotatu gabeko borobiltzeak R=2mm

31	1	Tapa 1	P10	F 1140	0.837 kg
38	1	Tapa 2	P10	F 1140	1.352 kg
Marka	Kant.	Izendapena	Arudia/Planoa	Materiala	Pisua
Marraztua :		Data	Izen-Abizenak	Sinadurak	 BILBOKO INGENIARITZA ESKOLA ESCUELA DE INGENIERIA DE BILBAO
Gainbegiratua :		29/10/2018	Julen Padrones Ligerio		
Homologatua :					
	Eskala	ESTALKIAK			PNEUMATIKOEN ERRODADURA SAIKUNTZA BANKUA
Perdoi Orok.	1:3				Plano Zkia. : P10
ISO 2768-m					Plano Kop. : 10 / 11

27.- N9 / (N7 /)

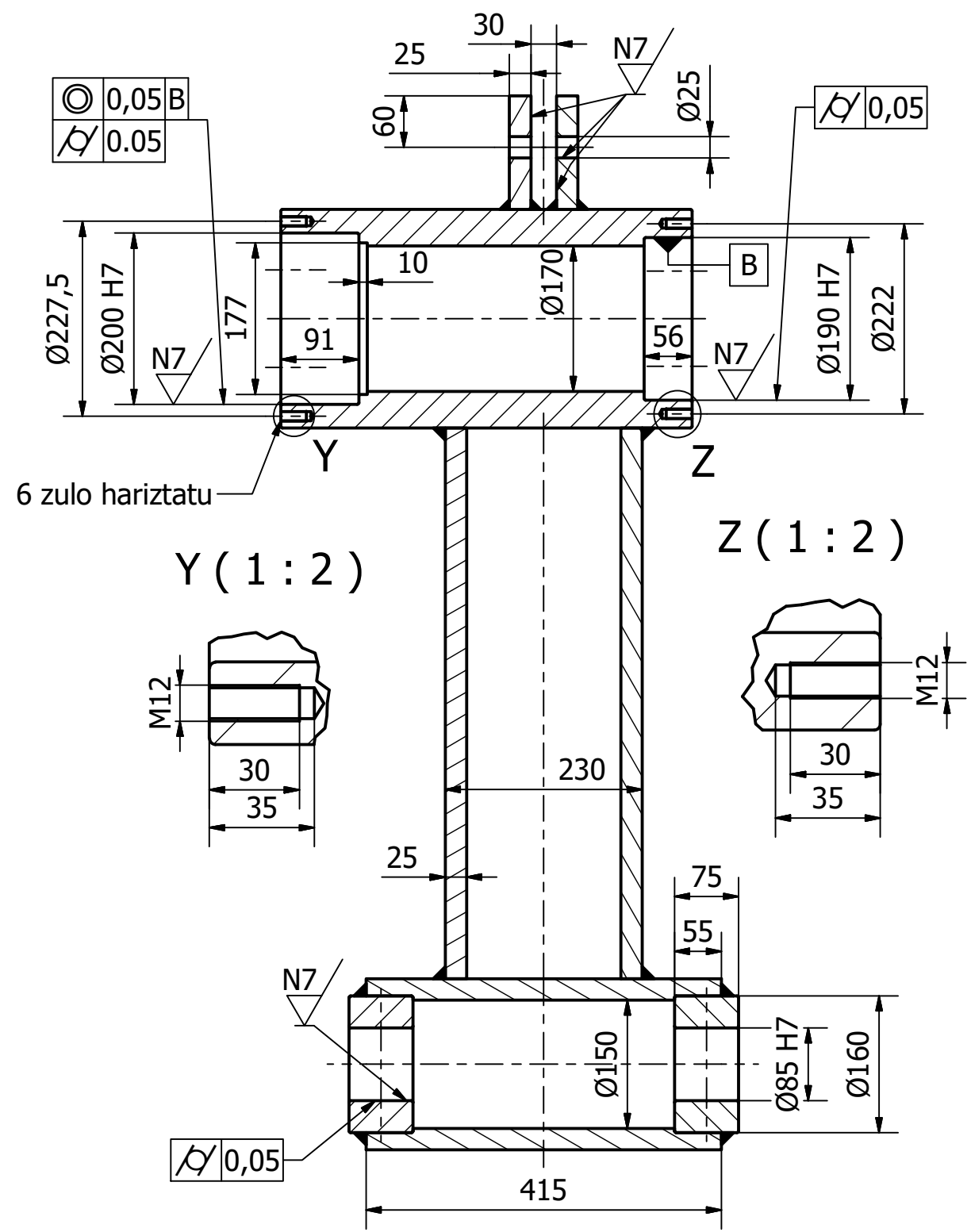
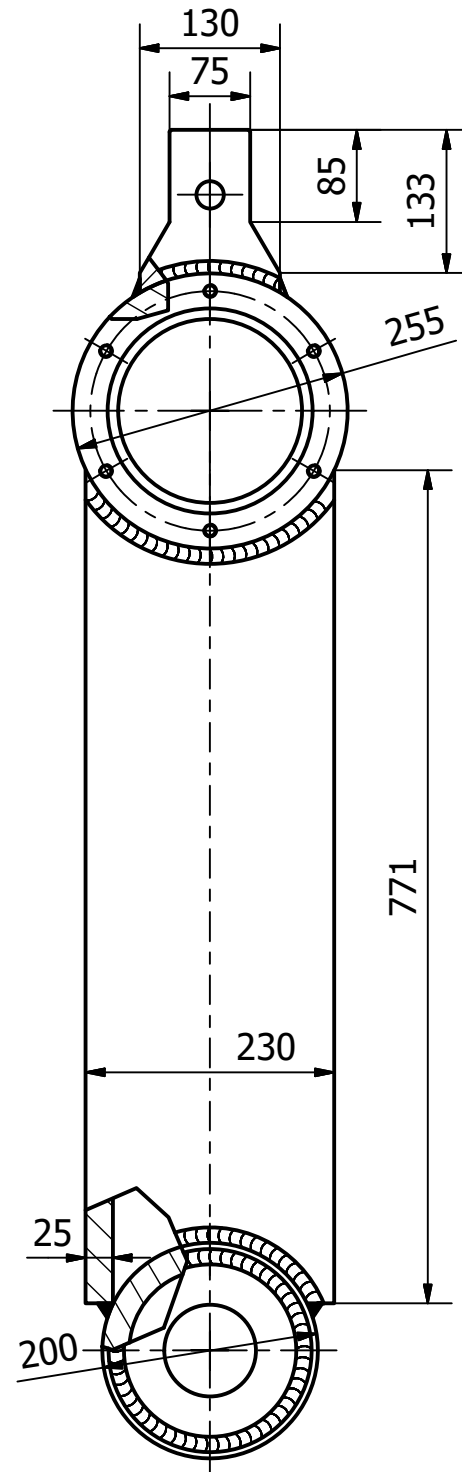
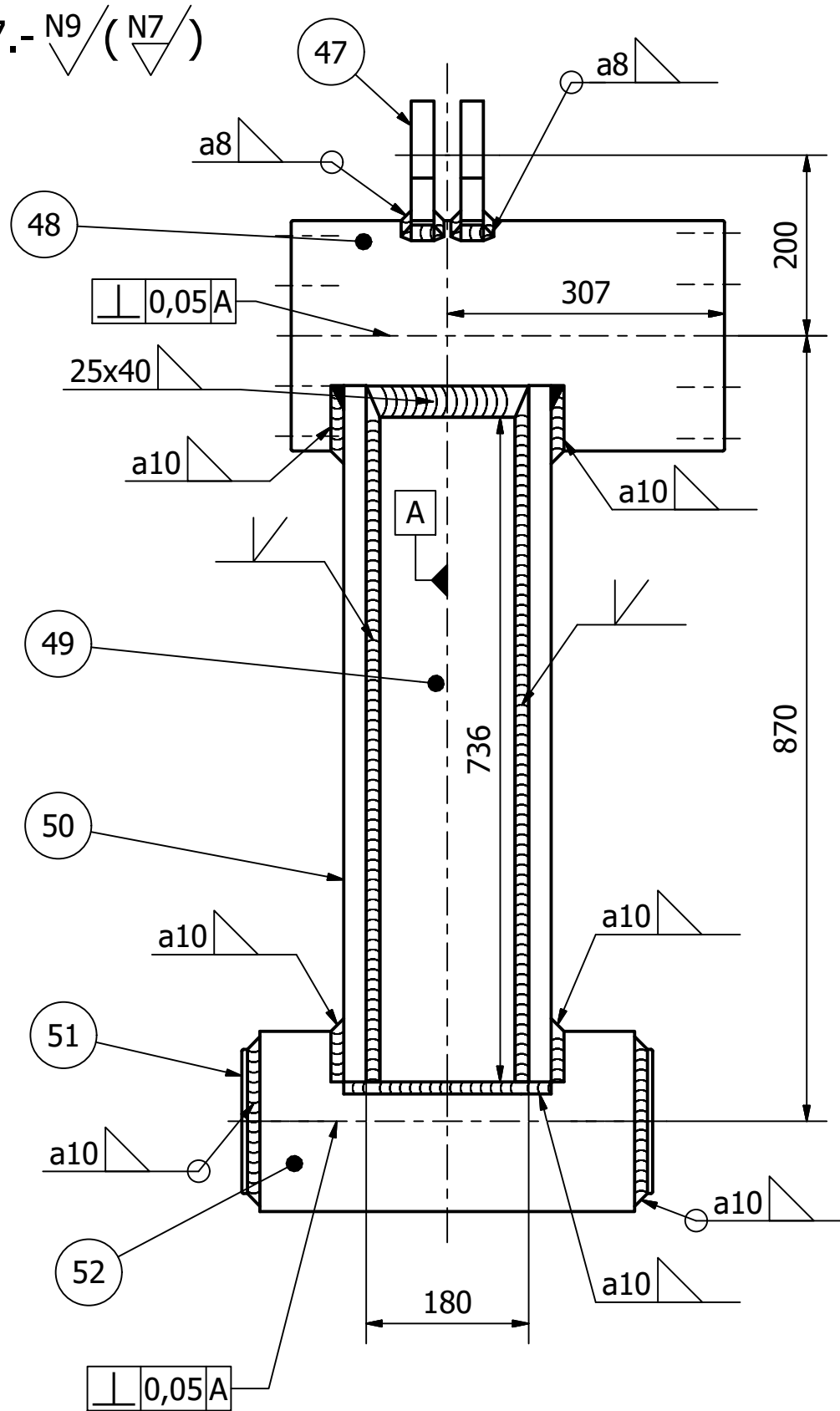

Akotatu gabeko borobiltzeak R=2mm

49	2	Xafla estua 736 x 180 x 25	P11	F 11140	3.312 kg
50	2	Xafla zabala 230 x 771 x 25	P11	F 11140	3.955 kg
51	2	Bermapuntuaren euskarria	P11	F 11140	1.081 kg
52	1	Bermapuntuaren ahokalekua	P11	F 11140	5.437 kg
Marka	Kant.	Izendapena	Araudia/Planoa	Materiala	Pisua

47	2	Palanka besoaren muturra	P11	F 11140	0.287 kg
48	1	Gurpilaren ardatzaren ahokalekua	P11	F 11140	12.452 kg
Marka	Kant.	Izendapena	Araudia/Planoa	Materiala	Pisua
Marraztua :		Data	Izen-Abizenak	Sinadurak	
Gainbegiratua :		29/10/2018	Julen Padrones Ligerio		
Homologatua :					
Eskala		1:7		PALANKA BESO SOLDATUA	
Perdoi Orok.		ISO 2768-m			
PNEUMATIKOEN ERRODADURA SAIKUNTZA BANKUA					
				Plano Zkia. :	P11
				Plano Kop. :	11 / 11

