

GRADO EN INGENIERÍA ELECTRÓNICA INDUSTRIAL
Y AUTOMÁTICA

TRABAJO FIN DE GRADO

AUTONIVELACIÓN DE MESA CON SENSORES ULTRASÓNICOS. DISEÑO Y SIMULACIÓN

ANEXO I - DATASHEETS

Alumna: Vidaurre, Gutiérrez, Famara

Directora: Otaegi, Aizpeolea, Aloña

Curso: 2020-2021

Fecha: 04, noviembre, 2020

ÍNDICE DE CONTENIDO

1. ARDUINO MEGA.....	1
2. REGULADOR DE TENSIÓN LM7809CT.....	3
3. SENSOR HC-SR04.....	5
4. MOTOR Y ACTUADOR LINEAL.....	7
5. DRIVER MOTOR XY-15AS PWM.....	15
6. SENSOR DE TENSIÓN FZ0430	16

1. ARDUINO MEGA

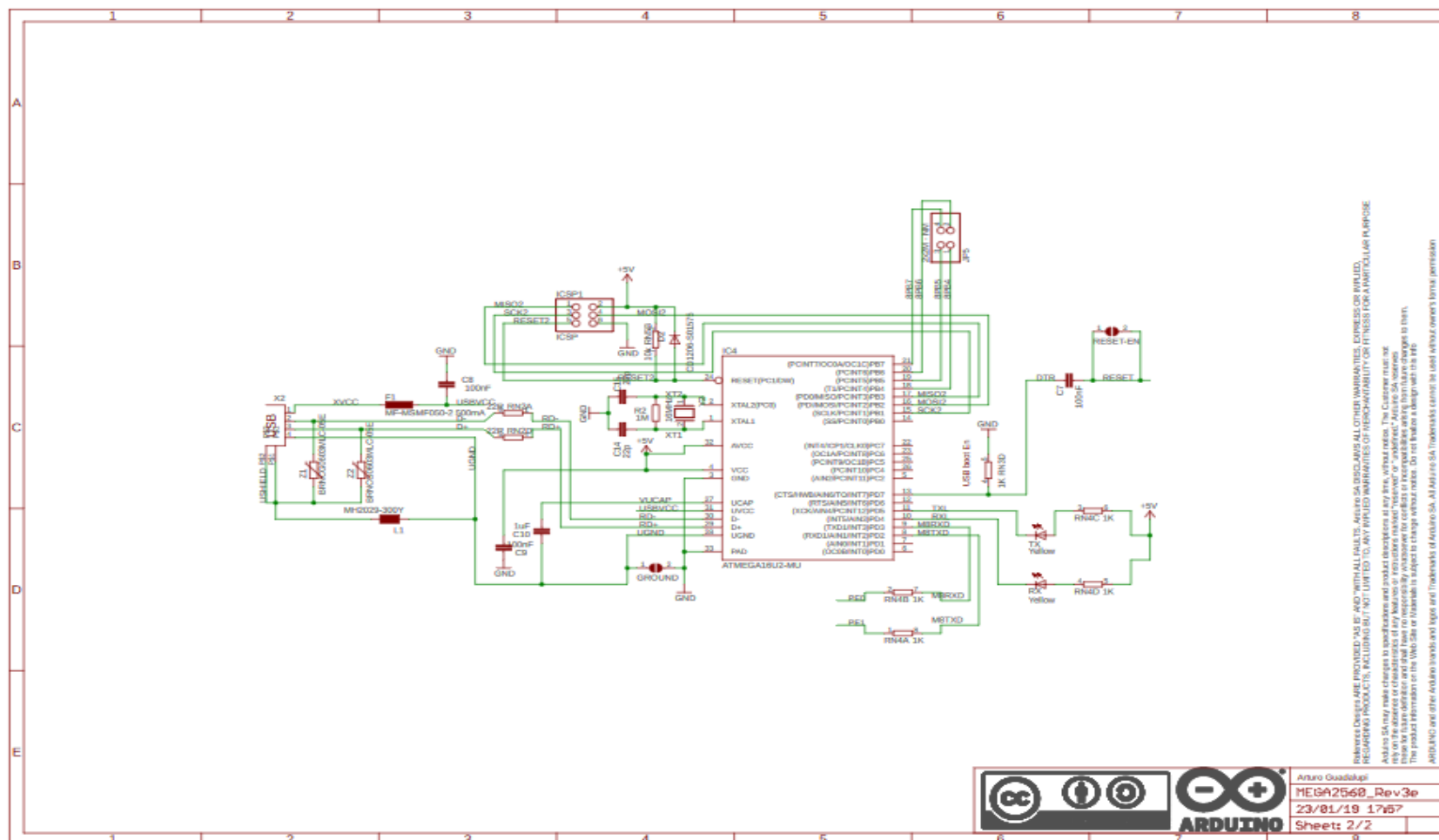

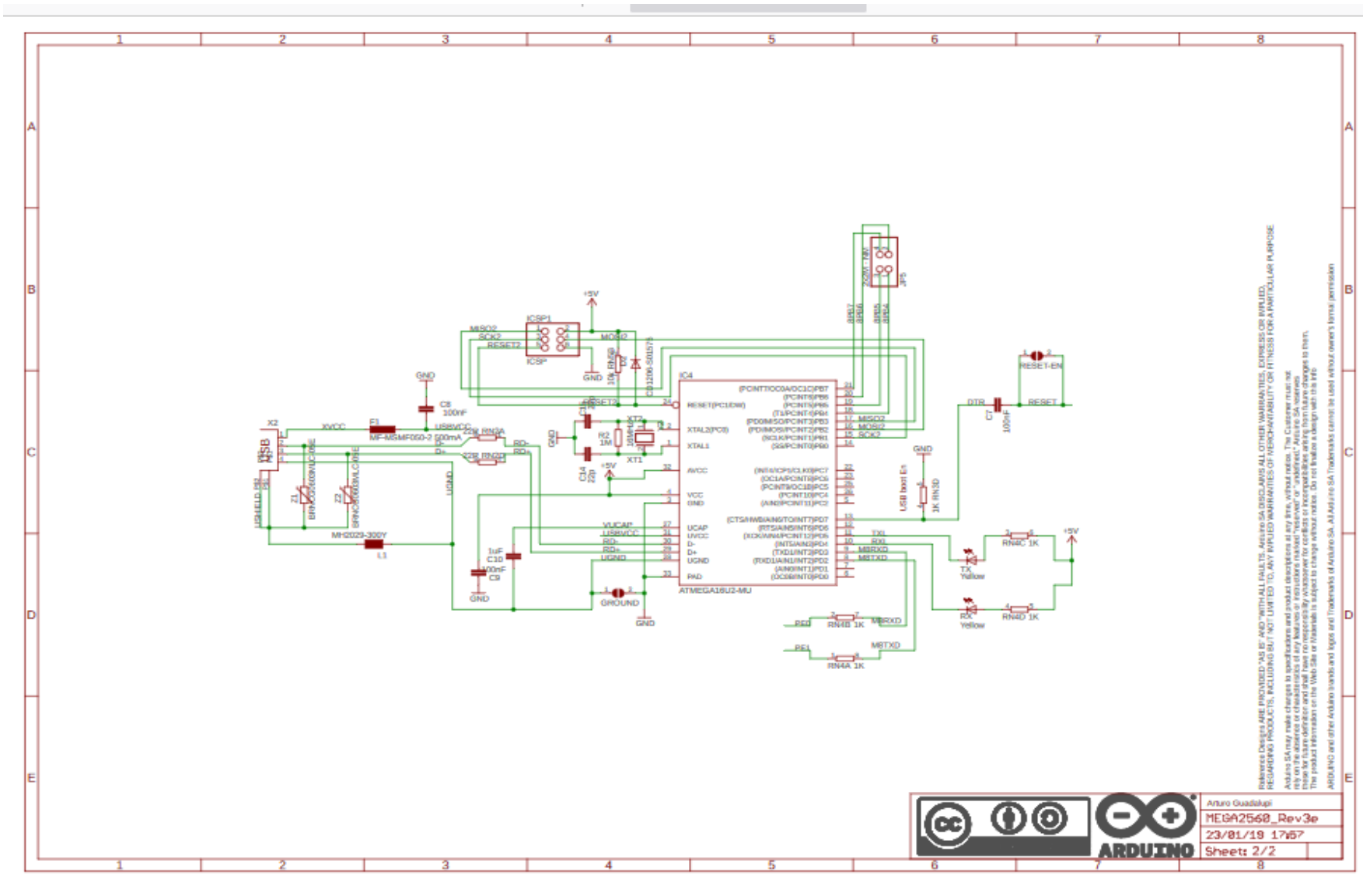

2. REGULADOR DE TENSIÓN LM7809CT



FAIRCHILD
SEMICONDUCTOR*



May 2006

LM78XX/LM78XXA

3-Terminal 1A Positive Voltage Regulator

Features

- Output Current up to 1A
- Output Voltages of 5, 6, 8, 9, 10, 12, 15, 18, 24
- Thermal Overload Protection
- Short Circuit Protection
- Output Transistor Safe Operating Area Protection

General Description

The LM78XX series of three terminal positive regulators are available in the TO-220 package and with several fixed output voltages, making them useful in a wide range of applications. Each type employs internal current limiting, thermal shut down and safe operating area protection, making it essentially indestructible. If adequate heat sinking is provided, they can deliver over 1A output current. Although designed primarily as fixed voltage regulators, these devices can be used with external components to obtain adjustable voltages and currents.

Ordering Information

Product Number	Output Voltage Tolerance	Package	Operating Temperature
LM7805CT	±4%	TO-220	-40°C to +125°C
LM7806CT			
LM7808CT			
LM7809CT			
LM7810CT			
LM7812CT			
LM7815CT			
LM7818CT			
LM7824CT			
LM7805ACT			
LM7806ACT			
LM7808ACT			
LM7809ACT			
LM7810ACT			
LM7812ACT			
LM7815ACT			
LM7818ACT			
LM7824ACT			

LM78XX/LM78XXA 3-Terminal 1A Positive Voltage Regulator

Block Diagram

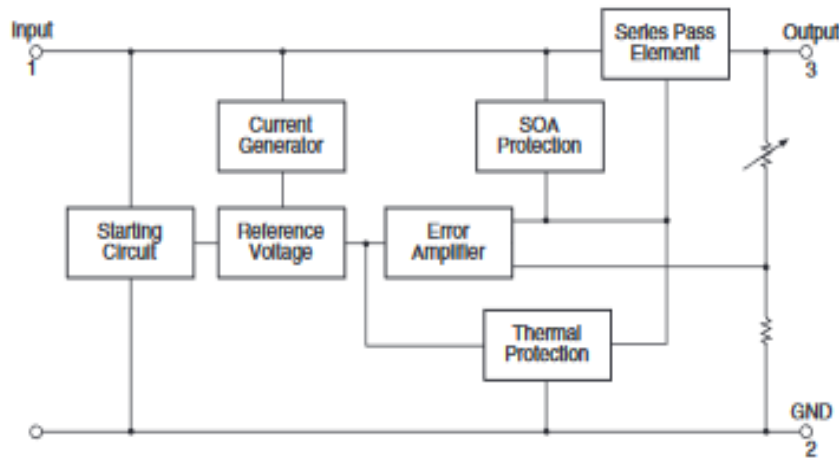

Figure 1.

Pin Assignment

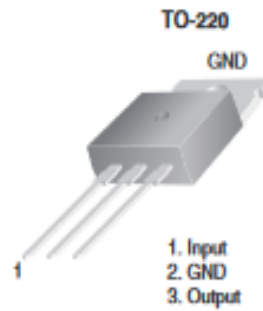

Figure 2.

Absolute Maximum Ratings

Absolute maximum ratings are those values beyond which damage to the device may occur. The datasheet specifications should be met, without exception, to ensure that the system design is reliable over its power supply, temperature, and output/input loading variables. Fairchild does not recommend operation outside datasheet specifications.

Symbol	Parameter		Value	Unit
V_I	Input Voltage	$V_O = 5V$ to $18V$	35	V
		$V_O = 24V$	40	V
$R_{\theta JC}$	Thermal Resistance Junction-Cases (TO-220)		5	$^{\circ}C/W$
$R_{\theta JA}$	Thermal Resistance Junction-Air (TO-220)		65	$^{\circ}C/W$
T_{OPR}	Operating Temperature Range	LM78xx	-40 to +125	$^{\circ}C$
		LM78xxA	0 to +125	
T_{STG}	Storage Temperature Range		-65 to +150	$^{\circ}C$

3. SENSOR HC-SR04

Ultrasonic Ranging Module HC - SR04

Product features:

Ultrasonic ranging module HC - SR04 provides 2cm - 400cm non-contact measurement function, the ranging accuracy can reach to 3mm. The module includes ultrasonic transmitters, receiver and control circuit. The basic principle of work:

- (1) Using IO trigger for at least 10us high level signal,
- (2) The Module automatically sends eight 40 kHz and detect whether there is a pulse signal back.
- (3) IF the signal back, through high level , time of high output IO duration is the time from sending ultrasonic to returning.

Test distance = (high level time × velocity of sound (340M/S) / 2,

Wire connecting direct as following:

- 5V Supply
- Trigger Pulse Input
- Echo Pulse Output
- 0V Ground

Electric Parameter

Working Voltage	DC 5 V
Working Current	15mA
Working Frequency	40Hz
Max Range	4m
Min Range	2cm
MeasuringAngle	15 degree
Trigger Input Signal	10us TTL pulse
Echo Output Signal	Input TTL lever signal and the range in proportion
Dimension	45*20*15mm



Timing diagram

The Timing diagram is shown below. You only need to supply a short 10 μ S pulse to the trigger input to start the ranging, and then the module will send out an 8 cycle burst of ultrasound at 40 kHz and raise its echo. The Echo is a distance object that is pulse width and the range in proportion. You can calculate the range through the time interval between sending trigger signal and receiving echo signal. Formula: $\mu\text{S} / 58 = \text{centimeters}$ or $\mu\text{S} / 148 = \text{inch}$; or: the range = high level time * velocity (340M/S) / 2; we suggest to use over 60ms measurement cycle, in order to prevent trigger signal to the echo signal.

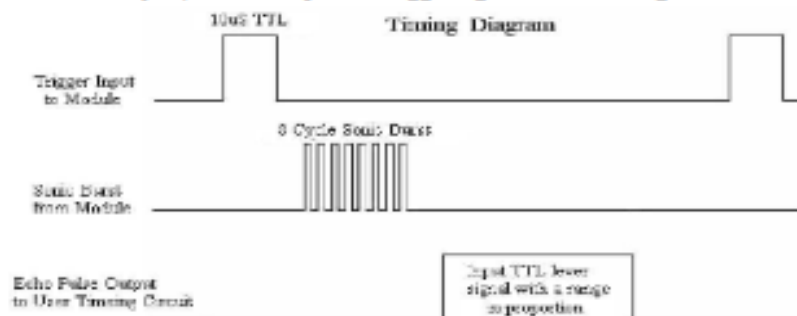

Attention:

- The module is not suggested to connect directly to electric, if connected electric, the GND terminal should be connected the module first, otherwise, it will affect the normal work of the module.
- When tested objects, the range of area is not less than 0.5 square meters and the plane requests as smooth as possible, otherwise, it will affect the results of measuring.

www.Electfreaks.com

4. MOTOR Y ACTUADOR LINEAL



Specifications

Load (LBS)		No Load Current (A)		Full Load Current (A)		Speed (inch/sec)	
Dynamic	Static	12VDC	24VDC	12VDC	24VDC	No Load	Full Load
100	100	4.0	2.0	12.0	6.0	2.80	2.16
400	400	4.0	2.0	12.0	6.0	0.98	0.78
600	600	4.0	2.0	12.0	6.0	0.50	0.30
900	900	4.0	2.0	14.0	6.0	0.47	0.39
1350	1350	4.0	2.0	14.0	6.0	0.31	0.24

Stroke	1" to 40"
Limit Switch	Internal - Non-Adjustable
Limit Switch Feedback	Available in 24VDC Only
Screw Type	ACME Screw
Motor Type	Brushed DC Motor
Connector Type	See Page 5
Wire Length	40" (customizable)
Housing Material	Aluminum Alloy
Rod Material	Aluminum Alloy
Gear Material	Polyformaldehyde
Color (Shaft)	Silver
Color (Motor End)	Black
Noise	<45dB
Duty Cycle	20% (4 minutes on, 16 minutes off)
Operational Temperature	-25°C to 85°C (-13°F to 149°F)
Protection Class	IP68
Feedback Options	Hall Effect, Reed Switch, or Limit Switch Feedback (see page 5)
Certifications	CE/RoHS (UL customizable)
Mounting Brackets	See Page 7
Mounting Ends	See Page 6



Dimensions

(Dimensions in inches)

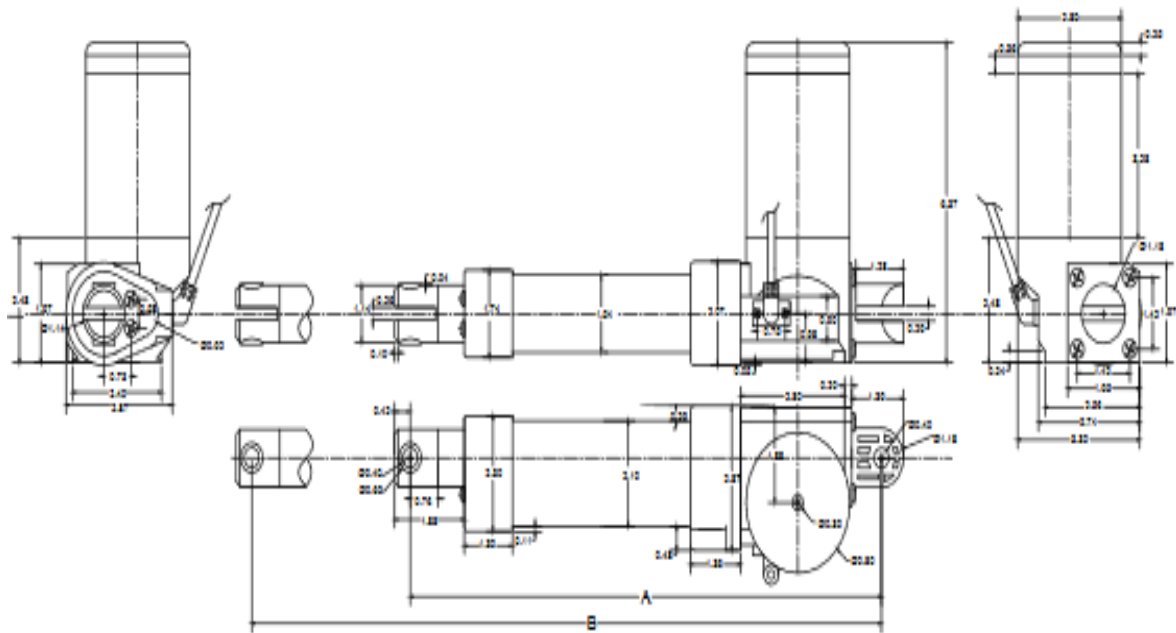

Hole to Hole

Stroke	1	2	3	4	6	8	9	10	12	14	16	18	20	22	24	30	40	60	80
PA-04 A	8.87	9.87	10.87	11.87	13.87	16.87	18.87	17.87	19.87	21.87	23.87	26.87	27.87	29.87	31.87	37.87	47.87	67.87	87.87
B	9.87	11.87	13.87	16.87	19.87	23.87	26.87	27.87	31.87	36.87	38.87	43.87	47.87	61.87	66.87	87.87	87.87	107.87	127.87

For Stroke Length

A = Stroke Length + 7.87"

B = Stroke Length x 2 + 7.87"



Speed vs Load

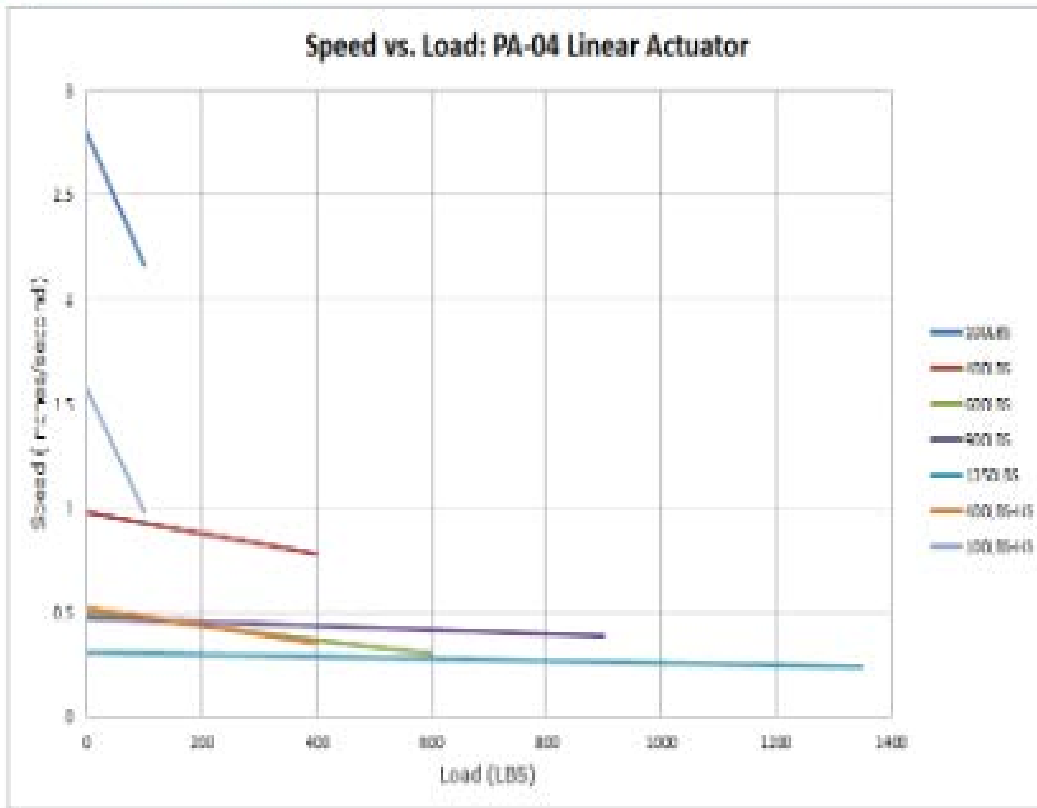

Current vs Load

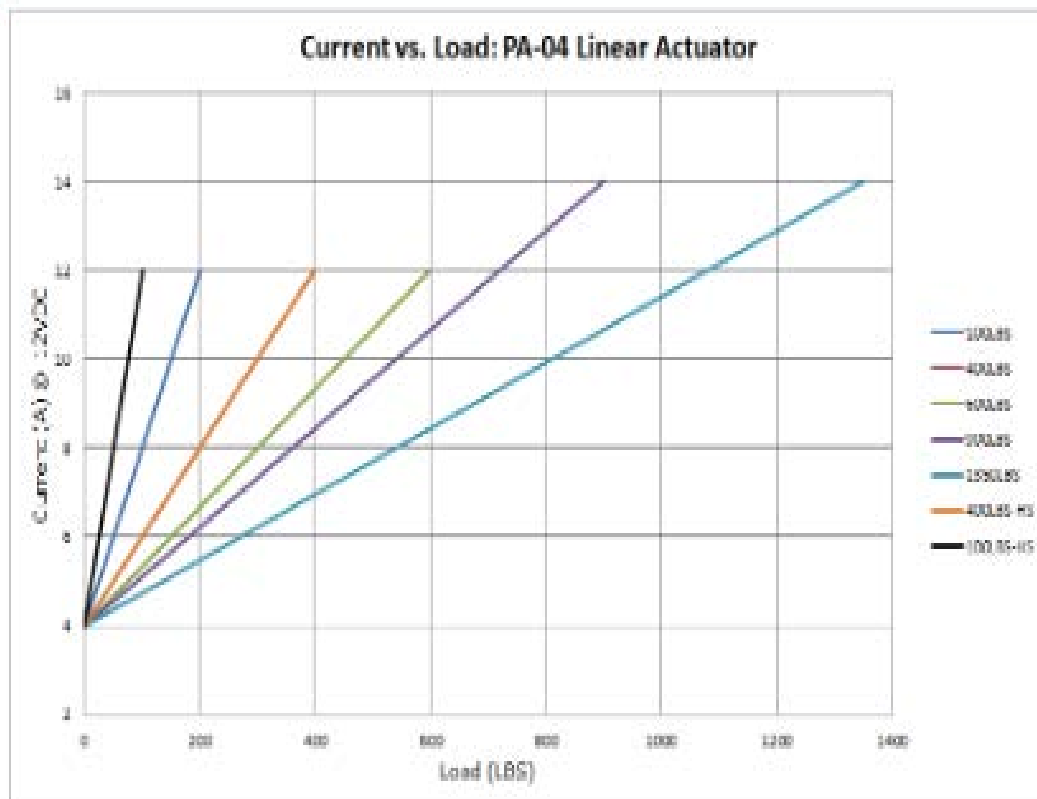



Connectors & Feedback

2-Pin Connector (Standard)



Motor	
1	2
M-	M+

Component	Part Name	Part Number	Mating Part Number
Housing	Molex Mini Fit Jr 2-Pin Receptacle	39-01-2025	39-01-3029/ 39-01-2028

6-Pin Hall Effect Connector

*For Stroke Lengths 6" to 40"

Front View

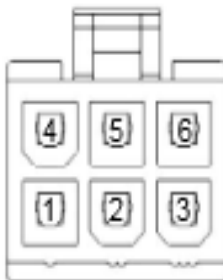

Motor		Hall Sensor			
4	5	2	3	1	6
M+ (Extend)	M- (Retract)	GND	+5VDC	Signal 2 Leads when Extending	Signal 1 Leads when Retracting

Component	Part Name	Part Number	Mating Part Number
Housing	Molex Mini Fit Jr 6-Pin Receptacle	39-01-2065	39-01-2069/ 39-01-2066

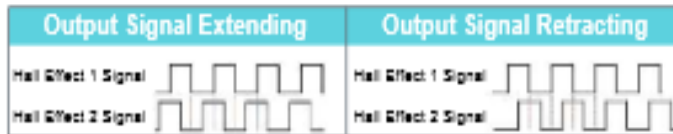

Force	Resolution (pulses/inch)
100	3,505
400	11,278
600	23,774
900	23,774
1350	30,480



Mounting Ends

H-Type Clevis (Standard)

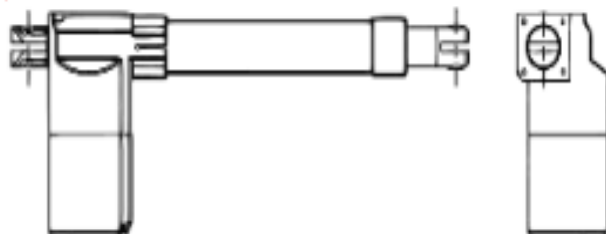

V-Type Clevis

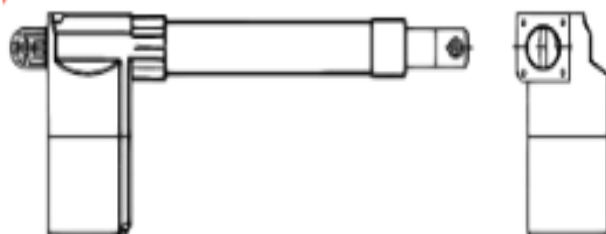

45 Degree Type Clevis 1

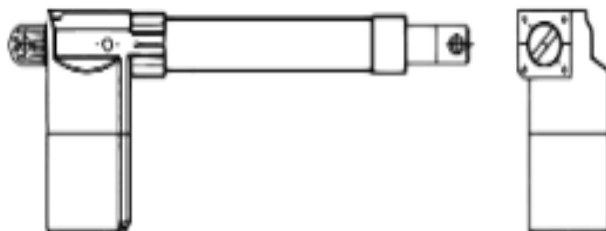

45 Degree Type Clevis 2

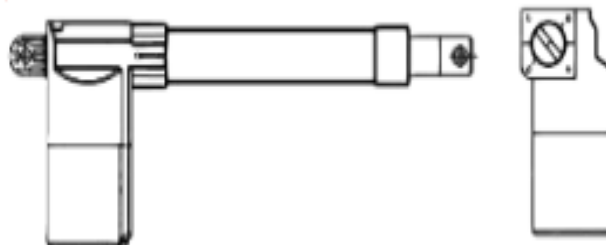

Mounting Brackets



(Dimensions in inches)

BRK-02

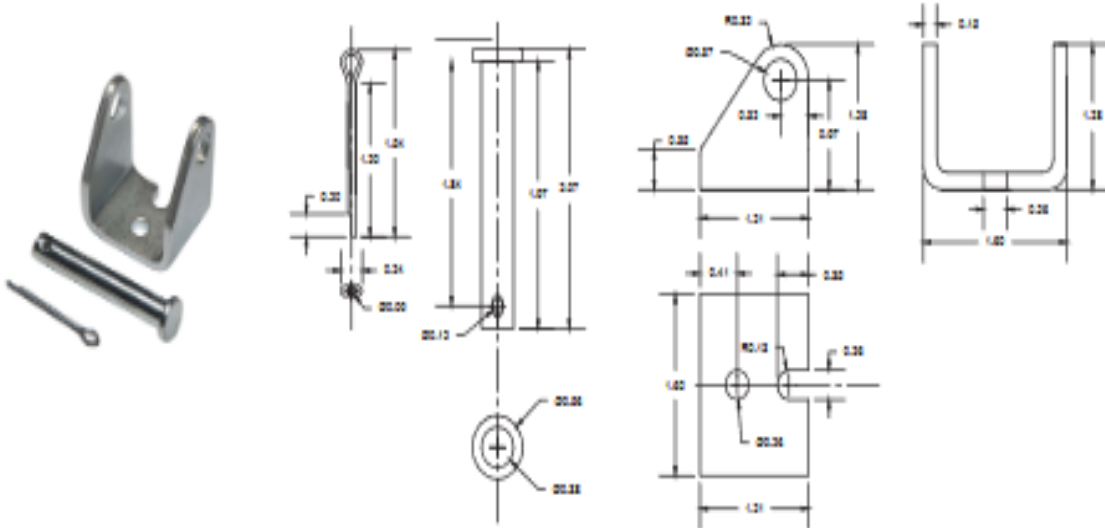

BRK-01

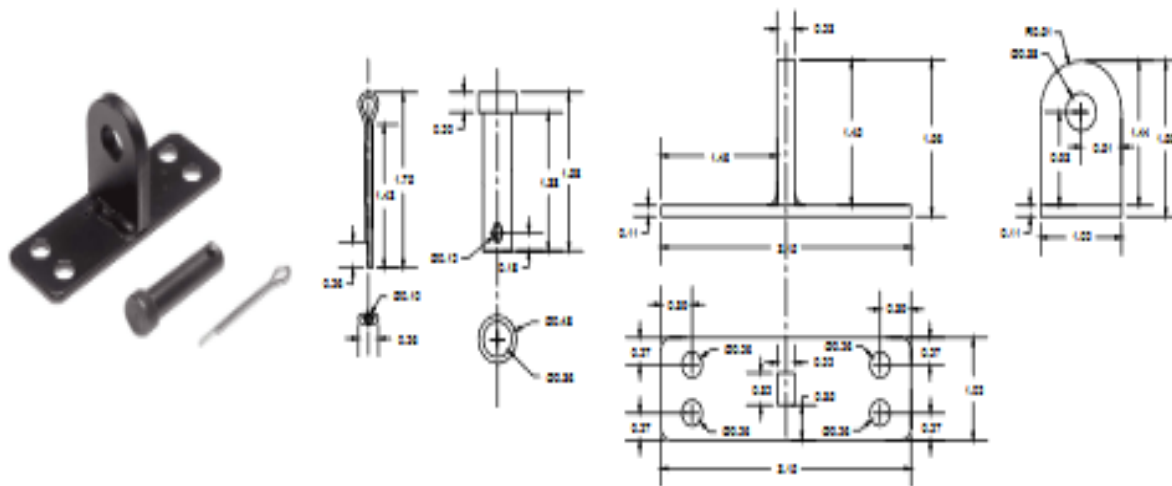

Internal Components

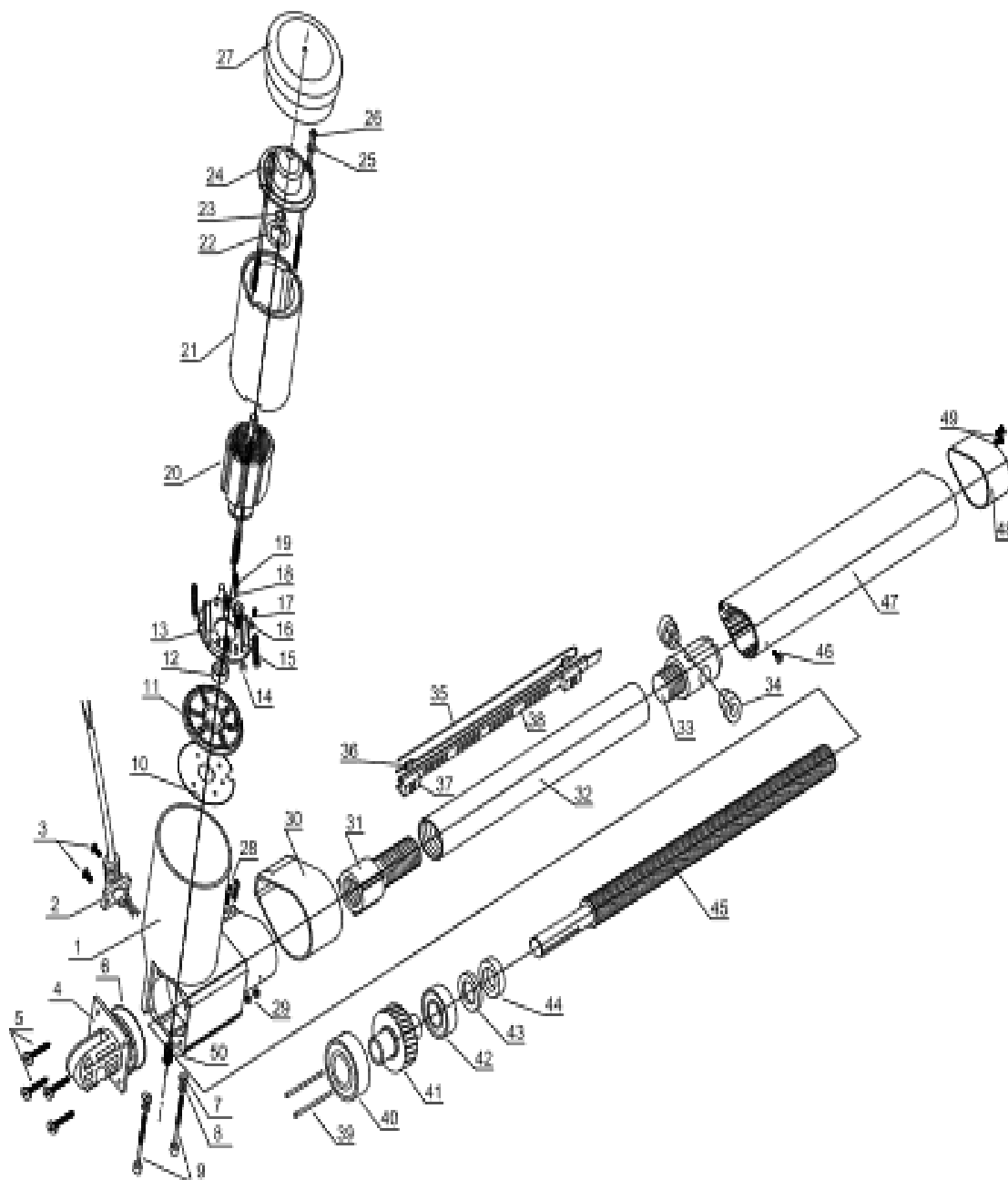

Internal Descriptions



Item	Description	Qty	Item	Description	Qty
1	Actuator Enclosure	1	26	Motor Screw	2
2	Power Cable With Mounting	1	27	Actuator Top Cap	1
3	Power Cable Screw	2	28	Shaft Enclosure Side Screw	2
4	Case Mounting Bracket	1	29	Shaft Enclosure Side Screw Nut	2
5	Mounting Bracket Screw	4	30	Shaft Enclosure Protector	1
6	Mounting Bracket O-Ring	1	31	Bottom Shaft Guide	1
7	Motor Unit Screw Washer	2	32	Shaft	1
8	Motor Unit Screw Spring Washer	2	33	Shaft Mounting Top	1
9	Motor Unit Screw	2	34	Mounting Hole Guard	2
10	Motor Case Gasket	1	35	Wire	1
11	Motor Base	1	36	Diode	2
12	Motor Lower Bearing	1	37	Limit Switch	2
13	Brush Holder PCB	1	38	Limit Switch Base	1
14	Capacitor	2	39	Drive Gear Wheel Pin	2
15	Inductor	2	40	Shaft Drive Bottom Bearing	1
16	Cable Lock	1	41	Drive Gear Wheel	1
17	Cable Lock Screw	1	42	Shaft Drive Bearing	1
18	Electric Motor Brush	2	43	Shaft Drive Small Spacer	1
19	Brush Spring	2	44	Shaft Drive Spacer	1
20	Electric Motor Rotor	1	45	Treaded Shaft Drive	1
21	Electric Motor Enclosure With Stator	1	46	Shaft Enclosure Screw	1
22	Top Bearing Holder	1	47	Shaft Enclosure	1
23	Top Bearing	1	48	Shaft Enclosure Top Cap	1
24	Motor Top Enclosure	1	49	Shaft Enclosure Top Cap Screw	1
25	Motor Screw Washer	2	50	Rotor Control Screw	1

5. DRIVER MOTOR XY-15AS PWM

Interface color discrimination

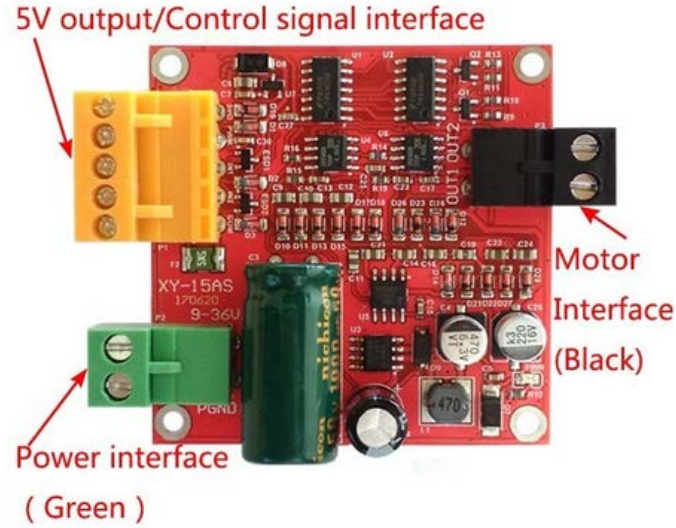

High power MOS with original 105A

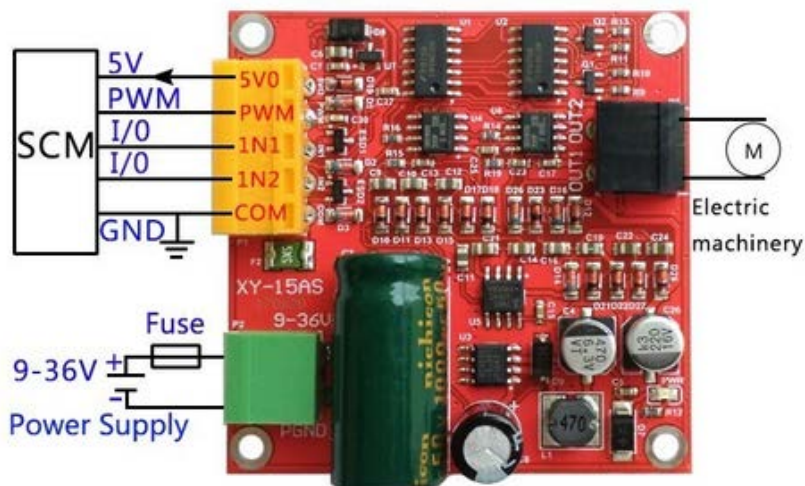
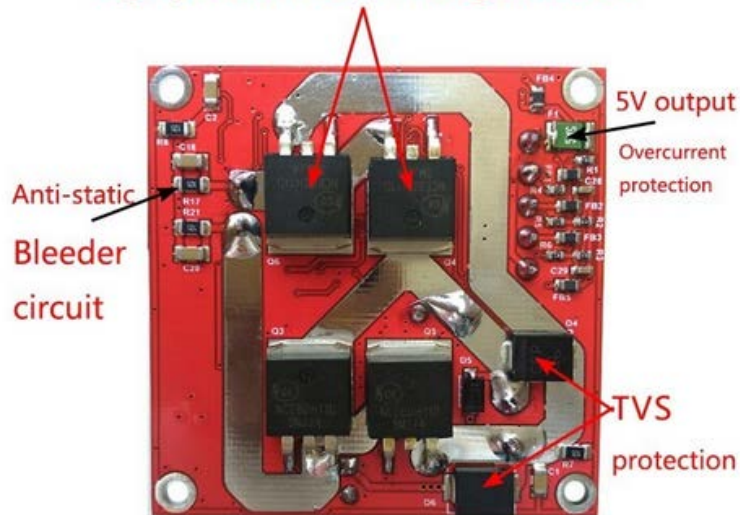

6. SENSOR DE TENSION FZ0430

Modulo Sensor de Voltaje FZ0430 0V - 25V, este módulo se basa en el principio de presión de los puntos de resistencia, y puede hacer que el voltaje de entrada se reduzca hasta 5 veces el voltaje original.

Por ejemplo, el voltaje máximo de entrada análogo de Arduino es de 5V, por lo que la tensión de entrada de este módulo no debe ser superior a $5V \times 5 = 25V$ (si el sistema con el que estamos trabajando es de 3.3V, el voltaje de entrada no debe ser superior a $3.3V \times 5 = 16.5V$)

Este modulo utiliza tecnología de 10 Bits AD, por lo que la resolución de este módulo es de aproximadamente 0.00489V (5V/1023), por lo que el mínimo valor de tensión a detectar es de 0.02445V.

Sensor compatible con Microncontroladores PIC, plataformas de desarrollo Arduino, Raspberry PI, entre otros.

Principales Características:

- Rango de alimentación VCC: 3.3V - 5V
- Salida Análoga
- Rango de Voltaje a medir: 0.02445V - 25V
- Resolución: 0.00489V
- Dimensiones: 25 mm x 13 mm

