

**BREAKING VERBS**

**FROM EVENT STRUCTURE TO SYNTACTIC  
CATEGORIES IN BASQUE**

Author: Ane Berro Urrizelki

Thesis supervisors:

BEATRIZ FERÁNDEZ FERNÁNDEZ (UPV/EHU)

RICARDO ETXEPARE IGINIZ (CNRS-IKER UMR 5478)

2015

Euskal Herriko Unibertsitatea-University of the Basque Country  
Université Bordeaux Montaigne

**BREAKING VERBS**  
**FROM EVENT STRUCTURE TO SYNTACTIC**  
**CATEGORIES IN BASQUE**

Ane Berro Urrizelki

2015

**Abstract**

This dissertation explores the subeventive decomposition and categorization of predicates in Basque. It provides an analysis where predicates are argued to consist of three basic components (processes, states and Rhemes). These components are combined to form the first phase syntax (Ramchand 2008). In this proposal, the verbal category is divorced from the first phase syntax and from a particular syntactic head (cf. Marantz 1997). For instance, categorization is understood as a process determined by both syntactic configuration and the way in which syntactic nodes are grouped in lexicalization. In particular, it is claimed that the verbal category is a post-syntactic configurational notion which emerges if the predicate is lexicalized out of the first phase syntax and in combination with tense. This proposal is supported by the analysis of Basque “derived” predicates and the analysis of the analytic verbal configuration of Basque. On the one hand, basing firstly on the study of complex unergative predicates, it is argued that a non-relational element surfaces as a noun if it is lexicalized separately from the head which defines aspect. This pattern of categorization is then applied to the verbal configuration as a whole, and is able to account for the nominal status of the suffixes (-*tu*/*-tze*) heading predicates in the analytic configuration. On the other hand, the analysis of location predicates (e.g. *etxe-ra-tu* [home-ALL-TU] ‘to go/take sb home’) reveals that a silent head *v* cannot be posited to be present, but instead, it suggests that the allative *ra* spells out the process head, a fact which points out that the verbal category must be separated from syntactic heads like process.



## Acknowledgements

Sometimes I felt as though this day would never arrive. If it has, it is because of all the people who have helped me during this long way. I am serious when I say that this dissertation has been the result of teamwork. These pages are not enough to express all the gratitude I feel for all these people, but, well, I hope that, at least, they serve as a small recognition.

Firstly, I want to show my deepest gratitude to my supervisors: Beatriz Fernández and Ricardo Etxepare. Without them, this dissertation would not be, obviously, what it has been in the end. Beatriz has always believed in me, even in moments I didn't, and has showed me how exciting (and sometimes hard) is doing linguistics. Without her unconditional professional and human support, I think I would not have been able to reach the end of this work. Ricardo has given me invaluable help. He has shared with me his endless knowledge about linguistics (as well as tons of books!) and has taught me to do the right questions (even if, at the beginning, those questions seemed to me like impossible to answer...).

I also want to thank to all the professors and researchers in the University of the Basque Country, CNRS IKER and other universities, that have, generously, listened to me, made me suggestions, and have helped me to do a better work: Pablo Albizu, Maia Duguine, Irantzu Epelde, Urtzi Etxebarria, Antonio Fábregas, Rafaella Folli, Aritz Irurtzun, Itziar Laka, Myriam Uribe-Etxebarria, Esther Torreño, Adam Zawiszeński. Special mention is due to Richard Kayne and other researchers and students from NYU and CUNY who took me so kindly during my stay in NYU in the fall of 2011.

Thanks to Xabier Artiagoitia, Mikel Santesteban, Dora Fernández and the whole department of Linguistics and Basque Studies. Many thanks to Antonio Fábregas and Rafa Marín for writing favorable reports and Jon Ortiz de Urbina for revising the English in some parts of the final version of the dissertation.

Many thanks are also due to Itziar Laka, Beñat Oihartzabal, Léa Nash, Jaume Mateu, Xabier Artiagoitia, Gemma Rigau, Jon Ortiz de Urbina, Pello Salaburu, Luis Eguren and Milan Rezac, who accepted to be in my dissertation committee.

Of course, I also want to mention the students of the Linguistics program and other programs in the University of the Basque Country that I have met these years: Borja

Ariztimuño, Alejo Alcaraz, Mikel Ayerbe, Irene Balza, Tania Barberan, Ander Egurtzegi, Nerea Eguskiza, Iratxe Esparza, Isabel Etxeberria, Isabel Garcia del Real, Wonsuk Jung, Dorota Krajewska, Bryan Leferman, Jon Ander Mendia, Amaia Munarriz, Ane Odria, Luis Pastor, Idoia Ros, Ekaitz Santazilia. It is incredible how much we learn from colleges! Many thanks also to Ibon Manterola, Leire Diaz de Gereñu and Aiora Jaka.

I want to thank specially Ane Odria. I can tell endless stories of the adventures of the two Ane-s, *bata bestea bezain despistatua. Zer egingo nuke nik gure terapia saioak gabe? Hurrengo zu, Anetxu!*

I also want to thank the anonymous informants from all over the Basque Country, who opened the doors of their houses to me and gave me very useful pieces of data. Additionally, I want to thank the people who helped me contact the informants: Irantzu Epelde, Leire Bidart, Maia Duguine, Iker Legarra, Asier Asueta, Ane Orue, Txomin Olaetxea and Maitane Barrenetxea.

Now, I have to thank my big family. I can write thousands of pages, but still, that would not be enough to compensate for all the help they have given to me. My mother Amaia and my father Josu have helped me in all the ways anyone can ever imagine: giving me emotional support, taking care of little Amets so that I could sit and write, revising some texts, cooking delicious meals for all of us, finding informants, driving the car in the numerous fieldwork trips when I was pregnant, and in many other ways. *Aitak dioen bezala, tribuari laguntzen*. Thanks also to my sister Irune, my brother-in-law Haritz and their little Oier, for their kindness and fun in those Friday evenings in Santutxu. *Ez duzue sinestuko baina bukatu dut azkenean!!!*

My other family, the one from Gamiz-Santurtzi, also deserves a pole position in the list. They represent another indispensable part of the teamwork which, at the end, has culminated in this dissertation. My mother-in-law Marian and father-in-law Angel have been always supportive and have helped me tremendously, taking us at home, taking care of Amets and simply making our lives easier. I also thank Janire, David, Josetxu and Conchi (whose croquettes and sponge cake are the best in the world) and the rest of the family in Santurtzi (*Cómo va la ka? Pues la ka no va. Además, ahora va de verbos, y resulta que al final no hay verbos! Mejor me retiro...*).

Another part of the family are my friends, the *txiri-txiri* cuadrila, the best cuadrila in Santutxu and surroundings. I thank them for listening to my moaning, always being positive and being sooo funny. Thanks to Maider, Haizea, Balentzi, Jone, Ari, Irati, Iser, Maitane, Ima, Josu, Leire (*eta bidean dagoena*), Nere, Bingen, Olatz, Andoni, Gere, Peru, Hanna, Txaber, Ane, Xabi, Oihane, Oihana, Larra eta Iomara. *Eskerrik*

*asko! Hurrengo bazkaria nire kontu!* Special thanks to Txaber Larreategi, for making the cover of this dissertation.

Finally, this dissertation is dedicated to my partner, Aingeru, and to our son Amets, for their kindness, patience, fun and the love they give me every day. Aingeru has contributed to this dissertation as nobody, being my personal coach every day (especially in the hard ones), and also, helping in more technical matters like for example, formatting the text of the final version. Needless to say, without his support and love, I definitely would not have been able to finish. For Amets, I think that the best thing I can tell him now is “no more Saturdays and Sundays sitting in front of the computer! (at least for a loong time). *Haientzat eta haiei esker bukatu dut. Eskerrik asko biei bihotz-bihotzez.*

The research leading to these results has received funding from the European Union's Seventh Framework Programme for research, technological development and demonstration under grant agreement no. 613465. Moreover, this research has been developed thanks to several projects funded by the Basque Government (the pre-doctoral grant BF109.203 and the project IT665-13) and by the Spanish Ministry of Economy and Competitiveness (FFI2011-26906 and FFI2014-51878-P).

All errors, of course, are my own responsibility.



*Aingeruri eta Ametsi*





# Contents

LABURPENA (euskara).....	1
RESUME (français) .....	9
<b>1. Introduction</b>	
1.1. Empirical scope and main goals of the dissertation.....	17
1.2. Event structure .....	20
1.2.1. Subevents, Rhemes and composition rules .....	20
1.2.2. Arguments and the derivation of theta roles .....	21
1.2.3. Situation aspect .....	24
1.3. Connection to lexicalization and categorization .....	29
1.3.1. Lexicalization and categorization of Roots.....	29
1.3.2. No verbal category .....	30
1.3.3. Decomposing categories .....	30
1.4. Connection to viewpoint aspect .....	32
1.4.1. Viewpoint aspect and categorization .....	32
1.4.2. The nature of viewpoint aspect .....	33
1.4.3. The nominal category of the predicate.....	34
1.5. Overview of the chapters .....	36
<b>2. Basic components of events and their arguments</b>	
2.1. Introduction.....	41
2.2. Background.....	42
2.2.1. The subeventive decomposition.....	42
2.2.2. First Phase Syntax.....	45
2.2.3. Flavors of v .....	49
2.2.4. About the lexicalization of predicates.....	50
2.2.4.1. Distributed Morphology .....	51
2.2.4.2. Nanosyntax.....	55
2.3. Events and arguments .....	58
2.3.1. Syntactic event decomposition and its interpretation.....	58
2.3.2. Properties of the measure denoted by Rhemes .....	65
2.3.3. Syntactic decomposition and aspectual interpretation .....	69

2.3.4. Arguments: internal and external subjects .....	73
2.4. Conclusions .....	78
<b>3. The syntax and lexicalization of unaccusative &amp; causative (derived) predicates</b>	
3.1. Introduction .....	81
3.2. Unaccusative and causative eventive predicates .....	83
3.2.1. “Derived” predicates .....	84
3.2.1.1. Predicates derived from Property naming Roots .....	86
3.2.1.2. Deadverbial -ka predicates .....	102
3.2.1.3. Deadpositional predicates .....	104
3.2.2. Underived predicates .....	107
3.2.3. -tu less eventive predicates .....	112
3.3. What about the external argument? .....	116
3.4. Conclusion .....	125
<b>4. Unergative &amp; non-causative transitive (derived) predicates</b>	
4.1. Introduction .....	129
4.1.1. On unergatives .....	130
4.1.2. On Rhemes .....	135
4.1.3. Outline .....	138
4.2. Morphologically simple predicates .....	140
4.2.1. Derived predicates .....	140
4.2.1.1. Predicates derived from Event naming Roots .....	140
4.2.1.2. Deadverbial -ka predicates .....	147
4.2.1.3. Cognates, hyponyms and other objects .....	150
4.2.1.4. On the non-dynamic ‘shine’ .....	154
4.2.1.5. Summary of conclusions .....	155
4.2.2. Non-derived predicates .....	156
4.2.3. Non-homomorphic direct objects .....	161
4.3. Morphologically complex unergative predicates .....	165
4.3.1. The ontology of Roots and aspectual classes .....	168
4.3.2. The subeventive decomposition and lexicalization of egin unergatives .....	172
4.3.3. The complementless restriction .....	174
4.3.4. The lack of internal subjects .....	179
4.3.5. The necessary external argument .....	181

4.4. The case of the “target” object and the simple/complex distinction .....	182
4.4.1. Aspectual contrast .....	182
4.4.2. Some gathered data .....	184
4.4.3. Dialectal variation: diminishing the aspectual factor .....	187
4.4.4. The introduction of the absolutive and dative argument .....	188
4.4.5. About push and call in telic predicates .....	191
4.5. Conclusion .....	197
<b>5. Adpositions, events and the verbal category</b>	
5.1. Introduction .....	201
5.2. The case of location predicates .....	202
5.2.1. Possible location predicates .....	202
5.2.2. Impossible location predicates .....	207
5.2.3. Concerning lexicalization .....	212
5.2.4. Events and adpositions .....	213
5.2.5. Conclusions .....	215
5.3. Considerations on the category of <i>-tu</i> .....	217
5.4. About categorization .....	224
5.4.1. The Generalization on Roots and abstract Case .....	224
5.4.2. Results revisited: lexicalization and categorization .....	225
5.4.3. Lexical and syntactic categories .....	227
5.4.4. A note on the Generalization on Roots and <i>-tu</i> .....	231
5.5. Conclusion .....	232
<b>6. The boundary between eventivity and stativity</b>	
6.1. Introduction .....	237
6.2. States .....	238
6.2.1. States in Hale & Keyser (2002) .....	239
6.2.2. Two types of states .....	242
6.2.2.1. D-states and K-states: Maienborn (2005 2007) and Rothmayr (2009) .	244
6.2.2.2. D-states in Fábregas & Marín (2012) .....	249
6.3. Subeventive decomposition of states .....	254
6.3.1. D-states and K-states in Basque .....	254
6.3.2. Syntactic diagnostics of dynamicity and eventivity in Basque .....	257
6.3.3. Summary of results .....	269
6.3.4. Decomposition of D-states .....	270

6.3.5. Decomposition of K-states .....	276
6.4. A note on unergative K-states .....	278
6.5. Conclusion .....	281
<b>7. The introduction of the external argument and the interaction between situation and viewpoint aspect</b>	
7.1. Introduction .....	285
7.2. Prediction on D- and K-states .....	287
7.3. Properties of the head introducing the external argument.....	290
7.3.1. Varying interpretations.....	290
7.3.2. Initiation in First Phase Syntax .....	292
7.3.3. Voice as WITH .....	294
7.3.4. Deriving theta-roles.....	300
7.4. Implications for subjects in intransitive K-states .....	303
7.5. Eventive/stative alternations and the external argument.....	307
7.5.1. From stative to eventive .....	307
7.5.1.1. Bare analytic predicates and transitive predication.....	307
7.5.1.2. Becoming eventive.....	312
7.5.2. From eventive to stative: participial transitive predication.....	314
7.6. Conclusion .....	324
<b>8. Decomposing verbal configurations</b>	
8.1. Introduction.....	329
8.2. Foundations.....	332
8.2.1. The synthetic vs. the analytic form .....	332
8.2.2. The nature of viewpoint aspect .....	337
8.2.2.1. Viewpoint aspect.....	337
8.2.2.2. Asp as a spatiotemporal relation .....	340
8.2.2.3. Asp as a stativizer.....	346
8.3. Deriving analytic and synthetic forms in Basque.....	350
8.4. Active Asp.....	354
8.4.1. The [+bound] Asp (AFTER) .....	354
8.4.2. The [-bound] Asp (WITHIN) .....	359
8.4.3. Eventive/stative alternation with <i>-tu/-tzen</i> .....	366
8.4.4. On the universal perfect and the [ $\pm$ bound] distinction.....	371
8.4.5. Excursus on the nature of <i>-tu</i> .....	375

---

8.5. Non-active Asp .....	379
8.5.1. The synthetic configuration .....	379
8.5.1.1. Viewpoint aspect in the synthetic configuration .....	381
8.5.1.2. Lexicalization and morphological consequences .....	384
8.5.2. Bare analytic predicates .....	384
8.5.2.1. Viewpoint and situational aspect in bare analytic predicates .....	385
8.5.2.2. On lexical insertion in bare analytic predicates .....	386
8.5.3. Some considerations on the perfective .....	387
8.6. Some historical notes and the function of Asp .....	390
8.7. Conclusions and further comments .....	393
8.7.1. Conclusions on Asp and the lexicalization of predicates .....	393
8.7.2. Future tense .....	396
8.7.2.1. The aspectual status .....	397
8.7.2.2. The modal status .....	398
<b>9. Conclusions</b>	
9.1. Summary of the main contributions of the dissertation .....	405
9.1.1. Subevents and temporal interpretation .....	405
9.1.2. The verbal category and the categorization of Roots .....	409
9.1.3. The boundary between stativity and eventivity .....	413
9.1.4. Viewpoint aspect and categorization .....	414
9.2. Considerations for the future .....	417
9.2.1. Aspects concerning dialectal variation .....	417
9.2.2. Cross-linguistic comparison .....	419
9.2.3. Relation with ergativity .....	420
9.2.3.1. Ergativity and the external argument .....	420
9.2.3.2. Ergativity and the nominal category of the predicate .....	424
References .....	427
ABBREVIATIONS .....	447



# Laburpena

## I. Abiapuntua

Doktore tesi honetan, predikatuen dekonposizioa eta lexikalizazioa arakatu ditut. Zehatzago, ikerketa honen helburu nagusia da aztertzea euskarazko aditzen –batez ere aditz eratorrien– barne-osaketa eta predikatu horien aditz konfigurazioa.

Euskaraz, beste hainbat hizkuntzatan bezala, predikatu asko sortzen dira izatez predikatu horietatik kanpo era beregainean erabiltzen diren elementuen gainean. Esterako, batzuek izen gisako elementuak hartzen dituzte oinarri (e.g. *ama*, *amatu* predikatuan eta *kanta*, *kantatu* predikatuan). Beste batzuk adjektiboen gainean eraikitzen dira (*lehortu* eta *etxegabetu lehorren* eta *etxegabe*-ren gainean) eta beste batzuk, aldiz, adlatibozko sintagmen (*etxeraturen kasuan*) edo sintagma instrumentalen (*urez-ta-turen kasuan*) gainean. Tesi honetan, horrelako predikatuen barne osaketa aztertu dut, baita haien kategorizazio-prozesua ere.

Bestetik, ikerketa honen beste iker ildo bat aditz konfigurazioak dira. Euskaraz, predikatuak bi aditz konfiguraziotan ager daitezke: sintetikoan (euskal tradizioan *trinkoa* deitu izan dena) eta analitikoan (tradizioan *perifrastikoa* deitzen dena). Forma sintetikoan azalera daitezkeen predikatuen kopurua nahiko txikia da. Izan ere, hamabost inguru dira konfigurazio sintetikoa erakusten duten aditzak (Euskaltzaindia 1997[1987]). Analitikoan, ordea, edozein predikatu ager daiteke, eta hizkuntzan etengabe sortuz doazen predikatu berriekin erabil daitezkeen forma bakarra da, gainera. Hona hemen forma sintetikoaren eta analitikoaren adibide bana:

- (1) a. Amets autobusean dator
- b. Amets autobusean etortzen da

Forma sintetikoan, predikatua bera komunztadura eta bestelako inflexio markekin batera azaltzen da hitz bakarrean (e.g. *dator*). Forma analitikoan, aldiz, bi hitz banatutan agertzen dira: alde batetik, predikatuak aspektu marka darama (*etor-tzen*), eta bestetik, inflexio markak aditz laguntzailean agertzen dira (*da*). Aspektu perfektuan eta perfektiboan predikatua *-tu* atzizkiaz lagundurik azaltzen da. *-Tu* atzizkia predikatuen izendapen forman eta testuinguru jokatu batean batzuetan agertzen da. Burutugabea, berriz, predikatuak *-tzen* atzizkiaz agertzen dira (1b). Tesi honetan proposatu dudanez, *-tzen* atzizkia izatez bi morfema beregainetan dekonposa daiteke: -



*tze* (tradizioan izengiletzat hartzen dena) eta *-n* inesiboa (ikus baita Mateu & Amadas 1999, Demirdache & Uribe-Etxebarria 2000, Laka 2004 2006). Azkenik, geroaldia adierazten duten aditz formetan, predikatuak, hizkeren eta predikatuen arabera, *-tu-ko* ala *-tu-ren* atzizkiekin agertzen dira. Kasu honetan, nabarmentzekoa da *-ko* eta *-ren* genitiboaren homofonoak direla.

Tesi honetan proposatuko dudanez, tradizioz datozkigun kategorietatik zenbait zalantzakoak dira edo besterik gabe ez dira existitzen. Guztien artean, aditz kategoria da zalantzarriena.

## II. Gertakari egitura

Tesi honetan proposatu dudanez, predikatuak hiru oinarritzko osagaitan dekonposa daitezke: prozesuak, egoerak eta Remak (Ramchand 2008a). Prozesuak eta egoerak azpigertakariak (*subevent* ingelesez) dira. Remak, aldiz, beren buru diren azpigertakariak deskribatzen eta neurtzen dituzten objektu sintaktikoak dira. Prozesuek *gertakari argumentu* bat (Davidson 1967) txertatzen dute, egoera azpigertakariak ez bezala. Egoerek, bestalde, beren espezifikatzailean subjektu bat gaineratzen duten bat-etortze harremanak dira.

- (2) a. Egoera(e): e bat-etortze harreman bat da.
- b. Prozesua(e): e espazio-denborazko entitate bat da.

Ramchandek (2008a) proposatu duen bezala, egoera azpigertakeriek adiera zehatzagoa lor dezakete prozesu azpigertakariarekiko duten harremanaren bitartez. Prozesua (*proz*) egoera batekin batzen denean, egoera *emaitza* moduan interpretatzen da. Aldiz, egoera prozesuarekin batzen denean, egoerak *abiatze* baten interpretazioa izango du.

## (3) Lehen Faseko Sintaxia

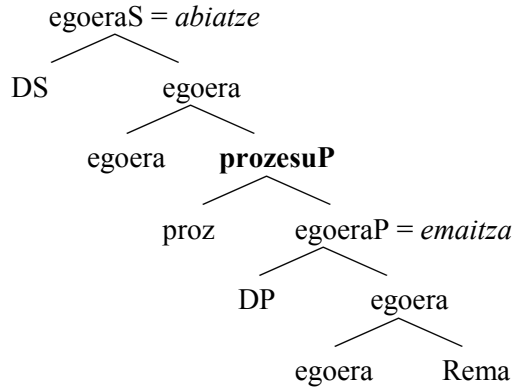

Prozesuak, egoerak eta Remak sintaxian elkartzen dira *Batze* (ingelesez, *Merge*) operazioaren bitartez. Alabaina, batzearen interpretazio semantikoa desberdina da bi azpigertakari elkartzen badira, edo azpigertakari bat Rema batekin elkartzen bada. Bi azpigertakari batzen direnean, bien arteko harremana kausazko inplikazio moduan ezartzen da (Hale & Keyser 1993, Ramchand 2008a). Bestalde, azpigertakari bat Rema batekin batzen denean, semantikak identifikaziotzat hartzen du bien arteko harremana. Lan honetan, identifikazioa maparatze (ingelesez, *mapping*) harreman bat dela proposatu dut (ikus Ramchand 2008a baita ere). Harreman horretan, Remarekin lotzen den neurriaren egiturak azpigertakariaren egiturarekin bat egiten du eta bien egiturak harreman homomorfitikoa batean daude. Hona hemen Remaren maparatze funtzioaren formalizazioa.  $p$  Remarekin lotzen den neurria da,  $p(i)$  neurriaren puntu bat eta  $e$  gertakari bat:

$$(4) \quad \text{RHEME}(p, e) =_{\text{def}} \forall e' \forall e \forall p [R(e, p) \cap e' \subseteq e \rightarrow \exists i [i \subseteq p \cap R(e', i) (\text{mapping to measure}) \cap \forall e' \forall p \forall i [R(e, p) \cap i \subseteq p \rightarrow \exists e' [e' \subseteq e \cap R(e', i)]] (\text{mapping to events})]$$

Formalizazioa honela irakurtzen da:  $e$  gertakari guztientzat,  $e'$  azpigertakari guztientzat eta  $p$  neurri guztientzat, baldin eta  $p$  R harremanean badago  $e$ -rekin eta  $e'$   $e$ -ren azpigertakari bat bada, badago  $i$  puntu bat zeina  $p$ -ren barruan dagoen eta R harremanean dagoen  $e'$ -rekin. Harreman hori neurriaren maparatzea (*mapping to measure*) deitzen zaio. Kontrako harremana formalizazioaren bigarren zatiari dagokio:  $e$  gertakari guztientzat,  $p$  neurri guztientzat eta  $i$  puntu guztientzat, baldin eta  $p$  R harremanean badago  $e$ -rekin eta  $i$   $p$ -ren barruan badago, badago  $e'$  azpigertakari bat zeina  $e$ -ren azpigertakaria den eta R harremanean dagoen  $i$ -rekin. Maparatze horri

gertakarien maparatzea (*mappint to events*) deitzen zaio (Krifka 1989, Ramchand 2008a).

Identifikazio harreman honen bitartez ezartzen da Remaren neurriaren ezaugarriek predikatu osoaren aspektu interpretazioa baldintzatzen eta zehazten dutela.

Ikerketa honetan, neurriak puntu multzoen bitartez irudikatzen dira. Puntu bakoitza zenbakizko balio bati dagokio eta multzo osoa Remaren ezaugarriarekiko monotonikoa da, hots, ezaugarriaren neurketaren hurrenkera harremanarekin bat dator. Aspektu interpretazioari eragiten dioten neurrien ezaugarriak honako hauek dira:

(5) Remari lotzen zaion neurriaren ezaugarriak

- a. [ $\pm$ emendiozkoa]
- b. [ $\pm$ gutxieneko muga]
- c. [ $\pm$ gehienezko muga]

[+emendiozkoa], [+gutxieneko muga] eta [−gehienezko muga] ezaugarriak dituen neurri baten adibide dira *kanta* edo, *handi* bezalako Erroak, baita *etxerantz* hurbiltze bidea ere. Zwart-en (2005) eta Pantcheva-ren (2011) bideen irudikapen grafikoan oinarrituta, neurri eskalarrak honela adieraz daitezke:

$$(6) \quad \begin{array}{c} kanta(p), \textit{handi}(p), \textit{etxerantz}(p) \\ - + + + + \rightarrow \infty \\ 0 \qquad \qquad \qquad 1 \end{array}$$

$p(0)$  eta  $p(1)$  dira hurrenez hurren  $p$  neurriaren hasi eta amaiera puntuak. Minusek [[*kanta*]], [[*handi*]] eta [[*etxerantz*]] denotazioen barruan ez dauden puntuak adierazten dituzte, eta plusek, berriz, barruan daudenak.  $p(0)$ -tik hurbil dagoen trantsizioak, alegia, minusetik plusera igarotzen den aldaketak, adierazten du neurri horiek gutxieneko muga bat dutela, hau da, trantsizio minimo bat behar dutela puntu bat denotazioaren barruan koka dadin. Bestetik, plusen lodierak neurria emendiozkoa dela adierazten du:  $p(i_n)$  puntuak  $p(i_{n-1})$  puntuak baino balio handiagoa dauka. Beste hitz batzuetan esateko, *kanta* neurriaren kasuan,  $p(i_n)$  puntua kantaren zati handiago bati dagokio  $p(i_{n-1})$  puntua baino; *handiren* kasuan, handitasun maila handiago bati, eta *etxerantz* neurriaren kasuan, etxerako bidean etxetik hurbilago dagoen espazio puntu bati. Azkenik, [ $\rightarrow \infty$ ] agertzeak neurriak gehienezko mugarik ez duela adierazten du. Neurria azkengabea da.

Remaren definizioan (3) dagoeneko adierazi dudana bezala, neurriaren puntu bakoitza azpigertakariari lotzen zaio era monotoniko batean. Horrela,

[+emendiozkoa], [+gutxieneko muga] eta [-gehienezko muga] diren neurriek gertakari dinamiko eta *atelikoak* sorrarazten dituzte: *kantatu* bezalako ekintzak eta *handitu* eta *etxerantz joan* bezalako apurkako lorpenak. Beste neurri mota batzuek, esate baterako, [+emendiozkoa], [-gutxieneko muga] baina [+gehienezko muga] direnek beste predikatu klase bat sorraraziko dute, hots, predikatu telikoa. Azken neurri mota horren erakusgarriak dira *etxeraino* amaieradun bidea, *lehor* Erroa eta *aurrekua* bezalako DSak.

### III. Lexikalizazioa eta kategorizazioa

Goian ikus daitekeen bezala, askotariko objektu sintaktikoak izan daitezke Remak: PSak, kuantifikatutako DSak eta Erroak (*kanta*, *handi* etab.). Tesi honetan aztertzen dudana beste alderdi bat Erroen kategorizazio prozesua da. Horretarako, hain zuzen ere, morfologikoki konplexuak diren predikatu inergatiboen analisisan oinarritu naiz lehenik, ondoren proposatzeko Erro bat izen baten moduan azaleratuko dela, baldin eta bere azpigertakaritik aparte lexikalizatzen bada.

#### (7) Erroen Orokorpena

Erroak izen moduan azaleratzen dira eta kasua behar dute zilegiztatzeko baldin eta beren azpigertakarrietatik banaturik lexikalizatzen badira.

Orokorpen horrek azaltzen du zergatik ezin duten inergatibo konplexuek Erroaz beste barne osagarririk hartu. Bestalde, nahiz eta orokorpen hori inergatibo konplexuen testuinguruan proposatu dudana, ondoren, erakutsi dut egoera-gertakarien lexikalizazio prozesuari ere ondo aplikatzen zaiola.

Nire analisiak inplikazio interesgarriak dakartza Erroen kategorizazioaren azterketara eta oro har, kategorizazioaren teoriara. Izan ere, Erroen Orokorpenak iradokitzen du Erro baten kategoria estatusa ez dagoela sintaxian zehaztua. Izen moduan azaleratzen diren Erroek ez dute izen kategoria jasotzen i buru funtzional batetik (Morfologia Banatuan proposatu ohi den bezala, e.g. Marantz 1997 2001 2007) eta ez dute erreferentzia indizerik (cf. Baker 2003). Hauena ez bezalako bidea urratu dut nik. Nire ustez, izen kategoria Erroaren azaleratzearen zehar-efektu bat da, Erroa ahoskatzen den konfigurazioaren ondorioa alegia. I kategoria lexikoak, edota i funtzio buruak ez dute prozesu hori eragiten (ikus Déchaine 2005 eta Déchaine & Trambly prestatzen hipotesi honen ildoko proposamen baterako).

Bestalde, aditz kategoriari dagokionez proposatu dut A eta a ez daudela sintaxian. *Etxeratu* bezalako kokapen aditzek erakusten dute ez dagoela adposizioa inkorporatu

zaion A isilik (Hale & Keyserren 1993 kontra). *Ra* ale lexikoa (adlatiboa deitu izan zaiona) zuzenean sartzen da prozesu-azpigertakarian, eta hori gertatzen da, hain zuzen, *ra*-k ahoskatzen dituen Helburu Sintagmak (Pantcheva 2011) eta prozesu Sintagmak (Ramchand 2008a) egitura topologiko eta sintaktiko homomorfikoa dutelako. Beraz, *ra* aleak prozesu burua lexikaliza dezake zuzenean, A isil baten beharrik gabe.

Bestetik, euskaraz ez dago a adizgilearen (Marantz 1997) aldeko inolako ebidentziarik. Euskarazko predikatu gehien-gehienak forma analitikoan azaleratzen dira beti, *-tu* edo *-tze* atzizkiez lagundurik. Ez dira denbora, modua edo persona/numeroa/kasua komuntadurarekin azaltzen, ez bada aspektu atzizkiekin bakarrik. *-Tze* eta *-tu* atzizkiek izen kategoria dutela proposatu dut. Lehenari dagokionez, ez da horren hipotesi harrigarria, *-tze* izengilea delako ustea nahiko orokortua dagoelako euskal hizkuntzalaritzan. Bigarrenari dagokionez, ordea, bestela pentsatu daiteke, *-tu* horrek adizgile baten itxura duelako *-ia* edozein elementu predikatu bihurtzeko balio baitu-. Dena dela, tesian erakutsi dudanez, *-tu* predikatuak izenak agertzen diren testuinguru sintaktikoetan agertzen dira, eta hortaz, izen kategoriarekin hobeto lotzen da, aditz kategoriarekin baino (ikus baita Haddican 2007, Haddican & Tsoulas 2012). Gainerakoan, forma sintetikoan azaleratu daitekeen aditzei dagokienez, proposatu dut haien azaleko “aditz” itxura azaleratze-konfigurazioaren ondorioa dela. Forma analitikoan ez bezala, sintetikoan predikatuak lehen faseko sintaxia baino gorago lexikalizatzen dira, goiko eremu funtzionaleko beste buru batzuekin batera, besteak beste, denborarekin batera (ikus Laka 1993b eta Arregi & Nevins 2012). Beraz, predikatu horien “aditz tasuna”, nolabait esateko, ez da sintaxiko buru funtzional batekin edo buru lexiko batekin lotzen, baizik eta predikatu horien lexikalizazio gunearekin (ikus Embick 2000 latineko forma sintetiko eta analitikoaren antzeko analisi baterako eta Svenonius 2007, non proposatzen den aditzak eta adposizioak bereizteko ezaugarri bakarra dagoela, hots, aditzek, adposizioek ez bezala, denbora izatea).

Hortaz, tesi honen ondorio garrantzitsu bat da, tradizioz datorkigunaren kontra eta gaur egun ere gramatika formalean onetsitakoaren kontra, I eta A kategoria lexikoak eta i eta a kategoriagile buruak ez direla existitzen sintaxian. Izen eta aditz kategoria sintaxiaren osteko konstruktuek dira eta, beraz, ezin dira definitu faktore sintaktikoetan bakarrik oinarrituz.

## VI. Kanpo aspektuarekiko lotura

Azkenik, Lakaren (1993b) eta Arregi & Nevinsen (2012) analisisian oinarrituz, proposatu dut forma analitikoan, predikatuak Asp –kanpo aspektuaren– buruaren osagarri gunean ahoskatu egiten direla. Hori dela eta, eta Embicken (2000) latineko forma analitikoaren analisiari segituz, predikatu horiek izen kategoriarekin azaleratu egiten direla aldarrikatu dut. Embickek (2000) dio Erroa Aspektura baino mugitzen ez denean, adjektibo baten moduan ahoskatu egiten dela. Aldiz, Erroa Aspektuarekin batera denborara mugitzen bada, orduan aditz baten moduan azaleratuko da. Haren arabera, lehenengo kasuan, ez dago adjektibotze prozesurik (i.e. aditza adjektibo bihurtuko duen Adj bururik). Predikatu horien adjektibo kategoria sintaxi-osteko ondorio bat izango litzateke.

Euskarara itzuliz, nire hipotesia Embickenaren antzekoa da: forma analitikoan predikatua lehen faseko sintaxiaren eremuan ahoskatzen da, Asp buruaren osagarri gunean eta Asp burutik banaturik. Horrek eragiten du predikatua izen kategoriarekin azaleratzea. Asp burua *-n* inesiboaren bidez ahoskatuko da testuinguru burutugabea, edo bestela, fonologikoki hutsa den ( $-\emptyset$ ) item lexiko baten bidez testuinguru burutuan.

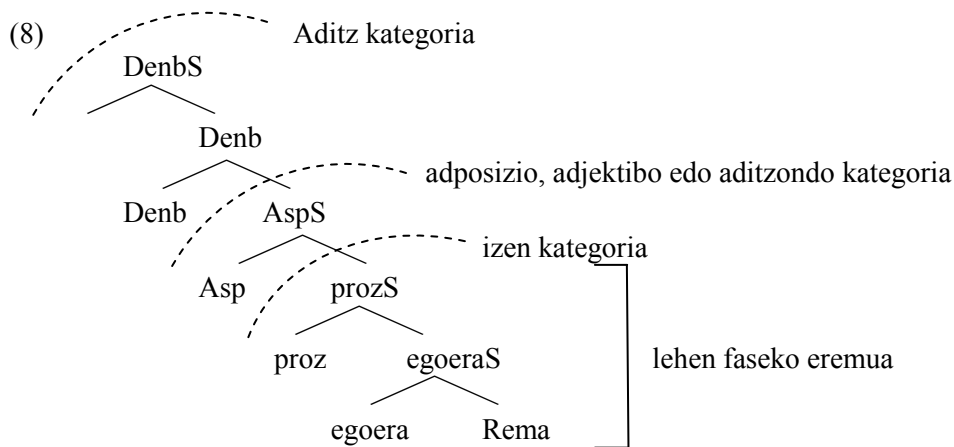

Forma sintetikoetan Asp burua ez da islatzen (Laka 1993b) eta horrek ondorioak ditu bai predikatuen interpretazioan (ikus Demirdache & Uribe-Etxebarria 2014), bai beren lexikalizazioan eta kategorizazioan ere. Asp ez dagoenean, predikatuak lehen faseko sintaxia baino gorago azaleratu daitezke, denbora eta beste inflexio buruekin batera, baldin eta lexikoki zehaztuta badaude horretarako. Bestela behean azaleratuko dira, izen kategoriarekin.

Predikatu osoaren kategorizazio eredu hau Erroen kategorizazio prozesuaren oso antzekoa da (7). Lehen faseko eremua bere burutik, hau da, Asp burutik, banaturik lexikalizatzen denean, izen kategoria egokitzen zaio. Aldiz, beste buru batekin batera lexikalizatzen bada, adibidez, Asp-ekin edo Denb-ekin, izenarena ez den beste kategoria bat egokitzen zaio, ez-izenarena (*non-noun* ingelesez), hain zuzen: adjektibo, adposizio edo aditzondo kategoria Asp-ekin azaleratzen denean, eta aditz kategoria, berriz, Denb-ekin ahoskatzen denean. Erroen kategorizazio eredu bera Asp, Denb eta lehen faseko sintaxiaren eremuan errepikatzeak zera adieraz dezake: kategorizazioa sintaxiaren eratorpenean behin eta berriz aplikatzen den, hots, errekurtsiboa den prozesua dela.

# Résumé

## I. Point de départ

Cette thèse se propose d'analyser la décomposition événementielle des prédicats et des configurations dans lesquelles ils sont lexicalisés. Concrètement, il s'agit d'étudier les prédicats verbaux dérivés en Basque. En Basque, comme à beaucoup d'autres langues, un nombre très important de prédicats sont composés sur la base des catégories autres que le verbe. Ces catégories peuvent être des noms (*ama-tu* 'devenir mère', du nom *ama* 'mère'; *kantatu* 'chanter', du nom *kantu* 'chant'), des adjectifs (*lehor-tu* 'essuyer, sécher' de l'adjectif *lehor* 'sèche', *etxe-gabe-tu* 'expulser à quelqu'un d'une maison' de l'adjectif *etxe-gabe* 'sans maison'), des adverbes *sail-ka-tu* 'classifier' de l'adverbe *sail-ka* 'en classes'), des syntagmes adpositionnelles (directionnelles, telles que *etxe-ra-tu* 'aller à la maison' de *etxe-ra* 'à la maison', ou des syntagmes instrumentaux, tels que *ur-ez-ta-tu* «arroser», composé de *ur-ez* 'avec de l'eau'). Une des objectifs de cette thèse est celui d'explorer les processus de composition syntaxique et de ré-catégorisation de ce type de prédicats.

Par ailleurs, cette thèse inclut aussi une étude des différents types de configurations verbales que l'on peut trouver en Basque. Les prédicats verbaux en basque se présentent sur deux formes générales : comme des prédicats analytiques et comme des prédicats synthétiques. Cette dernière catégorie est réduite à ce jour à une quinzaine de verbes (Euskaltzaindia 1997 [1987]), tandis que la forme analytique reste la seule à être productive. Voici une illustration de ces deux types de prédicat:

- (1) a. Amets autobus-ean dator  
Amets.ABS bus-INE venir.3sgABS  
'Amets vient dans le bus'  
b. Amets autobus-ean etorr-i da  
Amets.ABS bus-INE venir-TU être.3sgABS  
'Amets est venu dans le bus'

Dans la configuration synthétique (1a), les morphèmes d'accord et autres marques de flexion sont directement attachés à la racine du verbe, avec laquelle ils forment un seul mot. La configuration analytique, en revanche, est formée par deux mots séparés (1b) : un auxiliaire support, et un prédicat fléchi pour l'aspect grammatical. A la forme de parfait ou de perfective, ce prédicat est marqué par une tête *-tu*. *-Tu* est un suffixe



qui est aussi utilisé comme forme de citation des verbes en basque, et en certaines phrases d'infinitif. A la forme imperfective le suffixe est *-tzen/-ten*, qui peut être décomposé en *-tze* (un suffixe de nominalisation) et *-n* (le suffixe adpositionnel d'inessif). Dans les formes de futur ou de référence temporelle prospective, le prédicat verbale est marqué par la tête *-tu-ko* ou *-tu-ren* selon le dialecte. *-Ko* et *-ren* ont la même forme que les suffixes de génitif *-ko* et *-ren*. L'analyse des prédicats verbaux que je fais dans cette thèse m'amène à m'interroger sur le statut des catégories lexicales en général, et en particulier, sur la catégorie verbale.

## II. Structure événementielle

Je propose, en suivant le système de Ramchand (2008), que du point de vue événementiel les prédicats peuvent être décomposés en trois composants : Processus, État et Rhème. Les processus et les états sont des entités sous-événementielles, tandis que les Rhèmes, dans ce système, sont des objets qui décrivent ou mesurent le sous-événement dont ils sont le complément syntaxique. Je considère que les sous-événements dénotant un procès introduisent une variable de type *e* (événement, à la Davidson, 1967), tandis que les états ne le font pas (voir Fábregas et Marín 2012). Les états sont des relations de coïncidence centrale (voir Hale 1986), et ils introduisent un sujet dans leur spécificateur.

- (2) a. Etat (*e*) : (*e*) est une relation de coïncidence centrale
- b. Procès (*e*) : (*e*) est une entité spatio-temporelle

J'adopte l'hypothèse que, comme le propose Ramchand (2008), les états obtiennent une signification plus spécifique en vertu de leur positionnement relative au sous-événement procès. Quand le procès fusionne (dans le sens de Chomsky 2000) avec un état, l'état devient un résultat. Inversement, quand un état fusionne avec un procès, l'état est interprété comme un sous-événement d'initiation.

Les Processus, les États et les Rhèmes sont combinés en syntaxe par l'opération de fusion (*merge*). L'interprétation qui résulte de ces combinaisons est différente en fonction de si deux sous-événements ou un sous-événement et un Rhème soient fusionnés. Quand deux sous-événements sont fusionnés, la relation sémantique établie entre les membres combinés est interprétée comme une relation d'implication causale (Hale et Keyser, 1993 ; Ramchand 2008). En contraste, quand un sous-événement fusionne avec un Rhème, le composant sémantique interprète cette relation comme

une relation d'identification. Le terme *identification* doit être compris comme une relation de projection (*mapping*), dans laquelle la structure de la mesure associée au Rhème est dans une relation homomorphique avec le sous-événement. Je propose la formalisation suivante pour cette fonction de projection impliquant le Rhème, où  $p$  est la mesure associée au Rhème,  $p(i)$  un point de  $p$  et  $e$  un événement :

$$(3) \quad \text{RHEME}(p, e) =_{def} \forall e \forall e' \forall p [R(e, p) \cap e' \subseteq e \rightarrow \exists i [i \subseteq p \cap R(e', i)(\text{mapping to measure}) \cap \forall e \forall p \forall i [R(e, p) \cap i \subseteq p \rightarrow \exists e' [e' \subseteq e \cap R(e', i)]] (\text{mapping to events})]$$

(3) doit être lu comme suit : pour tout événement  $e$ , sous-événements  $e'$  et mesures  $p$ , ssi  $p$  adopte le rôle R vis-à-vis  $e$ , et  $e'$  est un sous-événement de  $e$ , alors il y a un point  $i$  appartenant à  $p$  qui est projeté dans le sous-événement  $e'$ . Ceci correspond à la notion de projection sur des mesures (*mapping to measures*). La projection sur des événements (*mapping to events*) signifie que pour tout événement  $e$ , mesure  $p$  et points  $i$ , ssi  $p$  est dans le rôle R vis-à-vis  $e$  et  $i$  est un point en  $p$ , alors il y a un sous-événement  $e'$  tel que  $e'$  est un sous-événement de  $e$  et il est dans le rôle R au point  $i$ . Cette relation garantit que les propriétés de la mesure associées au Rhème déterminent l'interprétation aspectuelle du prédicat.

Les mesures sont représentées ici comme un ensemble de points correspondant à des valeurs numériques qui sont organisés de manière monotonique en relation à la propriété dénotée par le Rhème (Ramchand 2008). Les aspects de la mesure qui déterminent l'interprétation aspectuelle du prédicat sont les suivantes:

- (4) Propriétés de la mesure associée au Rhème
- a. [ $\pm$  *incremental*]
  - b. [ $\pm$  *lower bound*]
  - c. [ $\pm$  *upper bound*]

Les racines *kanta* 'chant' et *handi* 'grand', ainsi que le sentier approximatif *etxerantz* 'vers la maison' peuvent être considérés comme des exemples de Rhèmes associés à des mesures qui possèdent les propriétés [ $+$ *incremental*], [ $+$ *lower bound*] et [ $-$ *upper bound*]. Si l'on s'appuie sur la représentation de sentiers proposée en Zwart (2005) et Pantcheva (2011), la mesure scalaire de ces objets syntaxiques peut-être illustrée comme suit:

$$(5) \quad kanta(p), handi(p), etxerantz(p)$$

$$\begin{array}{ccccccc} - & + & + & + & + & + & \rightarrow \infty \\ 0 & & & & & & 1 \end{array}$$

$P(0)$  et  $p(1)$  indiquent respectivement les points initial et le point final de la mesure  $p$ . Le moins indique les points qui ne sont pas dans la dénotation de  $\llbracket kanta \rrbracket$ ,  $\llbracket handi \rrbracket$  et  $\llbracket etxerantz \rrbracket$ , et les plus indiquent les points qui sont dans leur dénotation. La transition du point négatif au point positif qui succède  $p(0)$  montre que ces deux mesures ont une limite inférieure (*lower bound*), c'est-à-dire qu'elles ont besoin d'une transition minimale de telle manière qu'elles contiennent au moins un point dans leur dénotation. La grosseur des signes plus signale l'incrémentalité: un point  $p(i_n)$  est plus grand qu'un point  $p(i_{n-1})$ , c'est-à-dire qu'il correspond à une partie plus large du chant que le point  $p(i_{n-1})$  dans la dénotation du mot *kanta*, à un degré plus haut dans le domaine de l'amplitude dans *handi*, et à un point plus proche de la maison dans le cas d'*etxerantz*. La présence du signe  $[\rightarrow \infty]$  montre que la mesure n'a pas de limite supérieure.

Comme l'établit la définition de Rhème (3), chaque point de la mesure illustrée en (5) est projeté de façon monotonique sur un sous-événement. De cette manière, une mesure [+incremental] et [-upper bound] comme (5) produit un événement atélique de type dynamique : une activité dans le cas de *kantatu* 'chanter' et une réalisation de degré dans le cas de *etxerantz joan* 'aller vers la maison'.

### III. Lexicalisation et catégorisation

Comme nous avons pu l'observer des types différents d'objets syntaxiques peuvent constituer des Rhèmes : des syntagmes adpositionnelles, des syntagmes à déterminant ou même des racines. Le processus suivant lequel une racine qui n'a pas de catégorie inhérente dévient une entité avec une catégorie lexicale est abordé de manière spécifique dans cette thèse. Je défends l'idée qu'une racine qui a été envoyée en PF séparément de sa tête sous-événementielle doit paraître sous la forme d'un substantif. Une racine réalisée sous la forme d'un substantif doit en plus recevoir un cas. Cela donne lieu à la généralisation suivante :

#### (6) Généralisation sur les racines

Les racines sont réalisées comme des substantifs et doivent recevoir un cas si elles sont lexicalisées séparément de leur sous-événements respectifs.

La généralisation sur les racines explique pourquoi les prédicats inergatifs complexes ne peuvent pas avoir un objet autre que celui de leur racine. Cette généralisation s'applique aussi aux prédicats qui impliquent des sous-événements statifs.

Cette proposition a des conséquences intéressantes pour la catégorisation des racines. Elle suggère qu'une racine catégorisée comme substantif n'est pas catégorisée comme tel dans la composante syntaxique. Elle n'est pas labéllisée par une tête fonctionnelle de type n (comme il est parfois proposé dans des travaux basés sur la Morphologie Distributionnelle, Marantz 1997 2001 2007), et elle n'a pas d'index référentiel (à l'encontre de Baker 2003). Au contraire, elle avance l'idée que la catégorie nominale des racines émerge comme une conséquence de la configuration dans laquelle elle est réalisée en PF. Les catégories correspondent donc à l'interface syntaxe-morphologie, qui est une partie du module postsyntaxique. La catégorie lexicale N, ou le marqueur catégoriel n, ne sont pas du tout impliqués dans la catégorisation (voir aussi Dechaine 2005 et Déchaine et Tremblay en préparation).

Dans le cas de la catégorie verbale, je défends l'idée que les catégories v et V ne sont pas présentes en syntaxe. La formation de prédicats locatifs construits sur des syntagmes adpositionnels du type *etxe-ra-tu* 'aller à la maison' montre qu'il n'y a pas de catégorie V implicite à laquelle l'adposition et son complément seraient incorporées (contre Hale et Keyser 1993). L'item lexical *-ra-* (glossé habituellement comme une adposition allative) est directement insérée dans la tête *proc* (Procès) précisément parce que la structure topologique et la structure syntaxique de la phrase ProcP (Ramchand 2008) et GoalP (Pantcheva 2011) sont isomorphiques. *-Ra-* peut donc lexicaliser une tête sous-événementielle sans avoir recours à une tête de type V.

#### IV. Aspect externe

En m'appuyant sur les analyses de Laka (1993) et d'Arregi et Nevins (2013) sur la composition des verbes fléchis en basque, je propose que dans la configuration analytique le prédicat est "épilé" (envoyé en PF) dans sa position de complément de la tête aspectuelle qui correspond à l'aspect externe (Smith 1997 [1991]). Par ailleurs, en m'inspirant sur les travaux d'Embick (2000) sur les verbes déponents du Latin, j'avance l'idée que ce fait a comme conséquence que le prédicat adopte une catégorie nominale. Embick défend l'idée que quand une racine monte jusqu'à AspP mais pas au-delà, elle est épilée sous la forme d'un adjectif, tandis que si elle monte (avec Asp)

jusqu'à T, elle est épelée sous la forme d'un verbe. Dans le premier cas, il n'y a pas de processus d'adjectivisation proprement dit. En ce qui concerne le basque, je propose que sous la forme analytique, le prédicat, généré comme complément syntaxique de la tête aspectuelle, est catégorisé comme nominale. La tête aspectuelle est réalisée par le morphème inessif *-n* à l'imperfectif et par un item lexical phonologiquement nul au parfait.

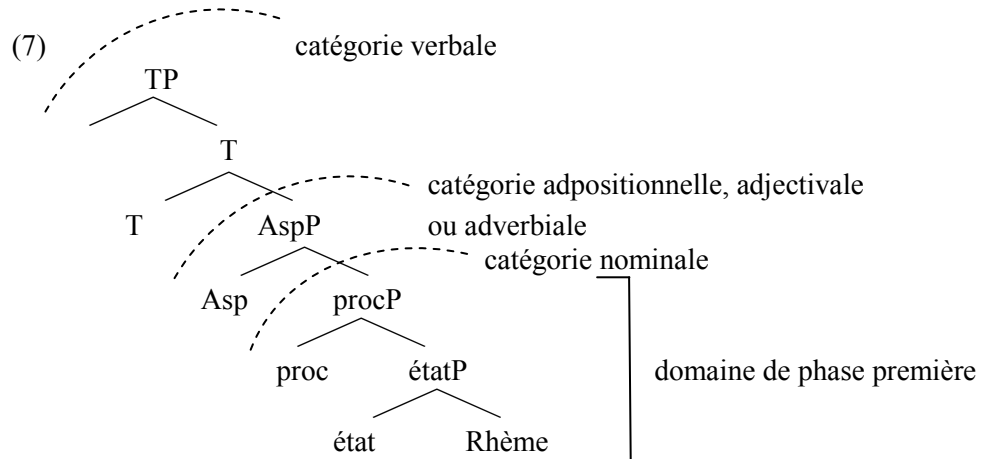

Dans le cas des formes synthétiques, AspP n'est pas projeté (Laka 1993). Ce fait a des conséquences pour l'interprétation aspectuelle (voir Demirdache et Uribe-Etxebarria 2014) et pour la lexicalisation/catégorisation des prédicats. Quand Asp n'est pas présent, les prédicats peuvent être lexicalisés avec T et le reste des éléments de la flexion, et être réalisés en tant que verbes.

# **1. Introduction**



## 1.1. EMPIRICAL SCOPE AND MAIN GOALS OF THE DISSERTATION

This dissertation analyzes the subeventive decomposition of predicates –particularly Basque predicates– and the configurations in which they are lexicalized. In Basque, like in many other languages, there are many predicates which are built on elements that are used independently out of the verbal environment. For instance, from a sample of 440 most frequent predicates taken from the *Contemporary Reference Prose* (Sarasola, Salaburu, Landa & Zabaleta 2011), using the browser Corsintax (Landa 2008), around 70 % is formed in this way.

These predicates usually consist of elements that are used independently as nouns (like *ama-tu* ‘to become a mother’ from *ama* ‘mother’, *kanta-tu* ‘to sing’ from *kanta* ‘song’) as adjectives (*lehor-tu* ‘to dry’ from *lehor* ‘dry’, *etxe-gabe-tu* ‘to evict’ from *etxe-gabe* ‘homeless’), as adverbs (*sail-ka-tu* ‘to classify’ from *sail-ka* ‘by classes’), as allative adpositional phrases (*etxe-ra-tu* ‘to go/take sb home’ from *etxe-ra* ‘to home’) and as instrumental adpositional phrases (*ure-z-ta-tu* ‘to water’ from *ure-z* ‘with water’).

- (1) Internazionala kanta-tu zuten denek [J.K.Igerabide, 2005: 59]  
International.the sing-TU have.3plERG.PST all.ERG  
‘The all sang the Internationale’
- (2) Eskuak belaun-etan lehor-tu nituen [R.Saizarbitoria, 2000: 115]  
hands knees-ine dry-TU have.1sgERG.3plABS.PST  
‘I dried my hands on my trousers’ (Lit. ‘in my knees’)
- (3) nik loreontziak ur-ez-ta-tu-ko ditut [J.Zabaleta (Pio Baroja) 2006: 127]  
I-ERG flowerpots water-INSTR-TA-TU-GEN have.1sgERG.3plABS  
‘I will water the flowerpots’

For notational convenience, I will call this kind of predicate “derived”, although by using this term I am not making any theoretical assumption about the derivation of these predicates from NPs, A(dj)Ps etc. As a matter of fact, one of the main objectives of this dissertation is to explore the relation between predicates and categorization.

As can be seen, these predicates are usually formed adding the suffix *-tu* to the element in question. *-Tu* is a suffix used in the citation form, in certain infinitive clauses and in the perfect/perfective forms of predicates. It alternates with the variants *-i/-n*, which used to be productive in previous stages of the language, but are no longer



used to form derived predicates nowadays. Apart from adding *-tu* directly to the element in question, derived predicates are also formed combining these elements with the light predicate *egin* ‘do’ (headed at the same time by *-n* in the citation form, a variant of *-tu*), as in *dantza egin* ‘to dance’ or *txalo egin* ‘to clap’.

- (4) Neska-rekin estu-estu dantza egi-te-n saiatu zen  
 girl-SOZ tight-tight dance do-TZE-INE tried be.3sgABS.PST  
 ‘He/she tried to dance stuck to the girl’  
 (Lopez de Arana (John Dos Passos) 1999: 413]
- (5) Joanes-ek ere txalo egin zuen gogotik [F.Juaristi, 2002: 144.]  
 Joanes-ERG also clap do-TU have-3sgERG.PST heartily  
 ‘Joanes also clapped heartily’

*Egin* derived predicates are always unergative, whereas those formed by *-tu* can be either transitive, unergative or unaccusative. Unaccusative and unergative/transitive predicates are overtly differentiated in Basque by the case marking of the subject and auxiliary selection. The subject of an unaccusative predicate is marked absolutive case (zero case), the same case assigned to the object of a transitive predicate. In contrast, ergative case (a marked *-k* case) is assigned to the subject of a transitive or an unergative predicate. In transitive and unergative predicates, the auxiliary \**edun* ‘have’ is selected, whereas in unaccusatives, *izan* ‘be’ is used.

- (6) (gu-k) (zuek) etxe-ra ekarr-i zaituztegu  
 (we-ERG) (you.pl.ABS) home-ALL bring-TU have.1plERG.2ABS  
 ‘we have brought you home’
- (7) (zuek) eror-i zarete  
 (you.pl.ABS) fall-TU be.2plABS  
 ‘you have fallen’
- (8) (gu-k) dantza-tu dugu  
 (we-ERG) dance-TU have.1plERG  
 ‘we have danced’

Among the *-tu* and *egin* derived predicates, we find predicates belonging to different aspectual classes. Some of them are activities (e.g. *kantatu* ‘to sing’ and *dantza egin* ‘to dance’), semelfactives (e.g. *txalo egin* ‘to clap’, *saltatu* ‘to jump’) or accomplishments (e.g. *galdetu* ‘to question’, *txiza egin* ‘to piss’). Finally, and especially among *-tu* headed predicates, we find predicates of change of state or position (e.g. *lehortu* ‘to dry’, *hurbildu* ‘to come/bring sth closer’). In this dissertation, I make a proposal which aims at explaining these different aspectual interpretations.

On the other hand, this dissertation also comprises the study of the different verbal configurations found in Basque. Basque predicates can appear in two types of configurations: in the synthetic configuration and in the analytic one. The synthetic form is nowadays restricted to about fifteen verbs (Euskaltzaindia 1997[1987]), while the analytic one can be used with all predicates and is the only form available for new predicates. Let me illustrate the two basic predicate forms by means of the following examples:

- (9) a. Amets autobus-ean dator  
 Amets.ABS bus-INE come.3sgABS  
 ‘Amets comes/is coming in the bus’  
 b. Amets autobus-ean etorr-i da  
 Amets.ABS bus-INE come-tu be.3sgABS  
 ‘Amets has come in the bus’

In the synthetic configuration (9a), agreement morphemes and other inflectional markers are directly attached to the root, forming a single word. The analytic configuration, in contrast, consists of two separate words (9b): an auxiliary (which can be *izan* ‘be’ or *\*edun* ‘have’ depending on the predicate or on allocutive agreement) and the predicate inflected for viewpoint aspect. As mentioned above, in the perfect and perfective, the predicate is headed by *-tu*. In the imperfective, it is headed by *-t(z)en*, which can be decomposed into what is usually considered a nominalizer *-tze* and the inessive *-n*. Finally, in future or prospective sentences, the predicate is headed by *-tu-ko* or *-tu-(r)en* –depending on the dialect and on the predicate. Note that *-ko* and *-(r)en* are homophonous with the genitive.

The analysis of Basque verbal predicates that I make in this dissertation will lead me to question the status of lexical categories, in particular, the verbal category. For instance, consider the following facts. In the analytic configuration, predicates seem to be nominal-like (i.e. *tze*) and, sometimes headed by adpositions (*-n* and *-ko*). Take now a denominal predicate like *dantzatu* ‘to dance’. A categorization process where a nominal *dantza* ‘dance’ turns into a verb, and then again becomes a nominal would be implausible. Why would syntax build a verb from a noun, and then turn it again into a noun? In this dissertation, I will consider these facts, and make a proposal concerning the event decomposition of predicates and their lexicalization and categorization. In the following sections, I will present briefly the main points of my proposal.

## 1.2. EVENT STRUCTURE

### 1.2.1. Subevents, Rhemes and composition rules

Following Ramchand (2008a), I will assume that there are two primitive types over subevents: processes and states. Departing slightly from Ramchand (2008b), I will consider that process subevents introduce an event argument (Davidson 1967), whereas states do not (see Fábregas & Marín 2012). States are central coincidence relations, which introduce a subject participant in their specifier.

- (10) a. State(*e*): *e* is a central coincidence relation  
 b. Process(*e*): *e* is a spatiotemporal entity

Processes and states combine in syntax by means of the operation Merge, as illustrated in (11):

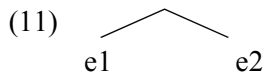

On the other hand, subevents can merge with syntactic objects which are not subevents by themselves. These objects are Rhemes (Ramchand 2008a):

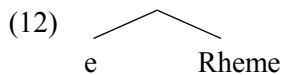

The semantic interpretation of the combination is different depending on whether two subevents are combined or a subevent is combined with a Rheme. When two subevents are merged together, the relation between the two merged members is interpreted as implication (Hale & Keyser 1993, Ramchand 2008a):

- (13) Event Compositional Rule (Implication) (Ramchand 2008a: 44)  
 $e = e1 \rightarrow e2$ : *e* consists of two subevents, *e1*, *e2* such that *e1* causally implicates *e2*.

In contrast, when a subevent merges with a Rheme, semantics interprets that combination as identification. Identification here must be understood as a mapping relation, where the structure of the measure associated to the Rheme stands in a homomorphic relation to the sub-structure of the subevent and vice versa. This way, the Rheme complement of the subevent does not represent a subevent by itself. It

rather describes and measures the subevent it is complementing. Building on Krifka (1989 1998) and Ramchand (2008a), I propose the following formalization of the mapping function performed by the Rheme, where  $p$  is the measure associated to the Rheme,  $p(i)$  a point of  $p$  and  $e$  is an event:

$$(14) \text{ RHEME}(p, e) =_{def} \forall e \forall e' \forall p [R(e, p) \cap e' \subseteq e \rightarrow \exists i [i \subseteq p \cap R(e', i) (\text{mapping to measure}) \cap \forall e \forall p \forall i [R(e, p) \cap i \subseteq p \rightarrow \exists e' [e' \subseteq e \cap R(e', i)]] (\text{mapping to events})]$$

In prose, (14) means that for all events  $e$ , subevents  $e'$  and measures  $p$ , iff  $p$  is in role R to  $e$ , and  $e'$  is a subevent of  $e$ , there is a point  $i$  belonging to  $p$  which is mapped to the subevent  $e'$ . This corresponds to *mapping to measures*. On the other hand, *mapping to events* means that for all events  $e$ , measures  $p$  and points  $i$ , iff  $p$  is in role R to  $e$  and  $i$  is a point in  $p$ , there is a subevent  $e'$  such that  $e'$  is a subevent of  $e$  and is in role R to the point  $i$ . In other words, this formulation ensures that the spatial structure associated to the Rheme is mapped to the sub-structure of the event.

I claim that all subevents have to be combined with either (i) another subevent, or (ii) a Rheme. Thus, a subevent will never be in the tail of the structure and all the non-subeventive complements of subevents will be interpreted as Rhemes.

### 1.2.2. Subjects and the derivation of their theta roles

I propose that subjects are introduced as specifiers of state subevents. State subevents convey central coincidence relations, and in order for them to be interpreted, they need to have a subject in their specifier.

States get a more specific meaning by virtue of their position with respect to the process subevent (Ramchand 2008a). When process (*proc*) merges with a state, the state becomes a result (*res*). In contrast, when a state merges with *proc*, the state is interpreted as an initiation subevent (*init*).

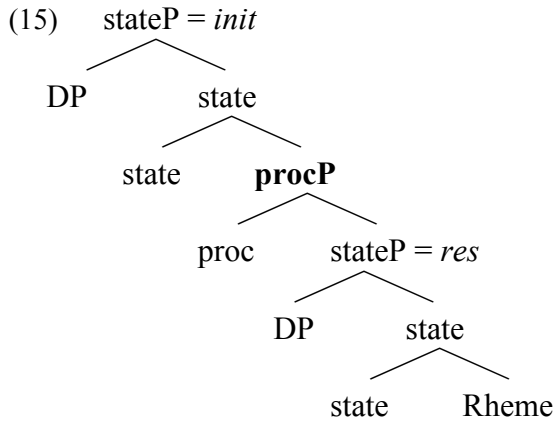

In this way, the subjects introduced by state subevents can be interpreted as RESULTEEs or as INITIATORS, depending on their location in the hierarchy. The structure depicted in (15) is the biggest configuration that a predicate can be decomposed into. Following Ramchand (2004 2008a et seq.), I will call this domain the First Phase.

The subject of a change of state predicate such as *ama-tu* ‘to become/turn sb into a mother’, is projected in the specifier of a state subevent, and thus, it gets originally a HOLDER theta role. Then, *proc* merges with the state, and, by implication, the state is interpreted as a *res*. The subject in the specifier position becomes, at the same time, a RESULTEE and an UNDERGOER.

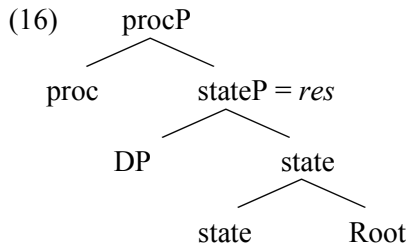

The derivation of the theta role of subjects of transitive or unergative predicates is slightly different. This kind of subject is introduced as the specifier of a state, like the subjects of predicates of change of state. However, this state subevent is not selected by *proc*, but instead, it selects for *proc*. By implication, when a state selects for a process, the state is interpreted as an initiation subevent, and the subject in its specifier gets the role of an INITIATOR. Thus, in this system, theta roles are derived from the whole first-phase configuration.

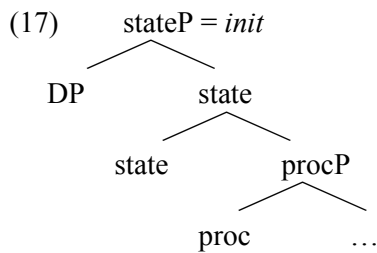

From this, it follows that the INITIATOR role is contingent on eventivity. If the state selects for a process subevent –which provides eventivity to the predicate– the state is interpreted as an initiation subevent. If not, it remains a state.

The dual stative/initiation nature of the head introducing the subject in transitive and unergative predicates is overtly observed in some Basque predicates, e.g. *amets izan* ‘to wish’ and *amets egin/amestu* ‘to dream’. The subject of a sentence like *askatasuna dute amets* ‘they long for liberty’ (lit. ‘they have liberty as a dream’) is an experiencer, basically characterized as a HOLDER.

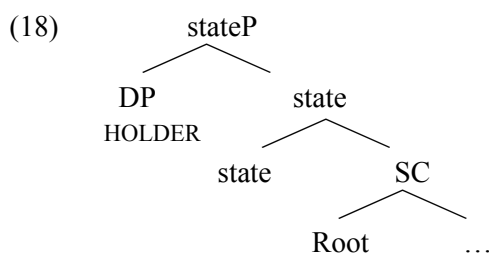

In an eventive sentence like *amets egin dute* ‘they have dreamed’, where the light predicate *egin* ‘to do’ is involved and a process head is projected, the state subevent introducing the subject is interpreted as initiation, and the subject, thus, as an INITIATOR.

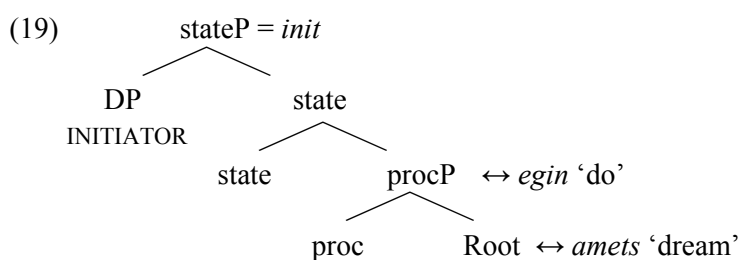

I will claim that the state subevent that is projected below *proc* –which I call the lower state– differs from the state projected above *proc* –the higher state– in two

important aspects. In the Basque analytic configuration,<sup>1</sup> the lower state subevent gets lexicalized in the predicate, whereas the higher state is not.<sup>2</sup> Secondly, the lower state may case-license its complement, if its complement is a nominal,<sup>3</sup> whereas the higher state may case-license an argument which is not in its complement position, e.g. the subject of a lower state. In this respect, the higher state is similar to both the Voice head (Kratzer 1994 1996) and little *v* (Chomsky 1995).

### 1.2.3. Situation aspect

This section deals with the way properties of the measure associated to the Rheme determine the temporal interpretation of the whole predicate. The homomorphism relation established between *proc* and its Rheme is slightly different from the relation established between a state and its Rheme. The structure of measure of a process Rheme maps to the temporal progress of the event, whereas the structure of a measure associated to the Rheme of a state brings consequences for the atomic or non-atomic interpretation of the central coincidence relation. I will firstly explain the properties of the measures associated to the Rhemes, and then, I will return to their implications for process and state subevents.

Measures are represented here as a set of points which correspond to numerical values and which are monotonic on the property denoted by the Rheme (Ramchand 2008a). The aspects of measure that determine the aspectual interpretation of the predicate are:

- (20) Properties of the measure associated to the Rheme
- a. [ $\pm$ incremental]
  - b. [ $\pm$ lower bound]
  - c. [ $\pm$ upper bound]

Examples of Rhemes which are associated to measures having [+incremental], [+lower bound] and [-upper bound] properties are the Roots *kanta* ‘song’ and *handi* ‘big’, and the approximated path *etxerantz* ‘towards home’. Building on the graphic

---

<sup>1</sup> As I have mentioned in section 1.2, the analytic configuration is predominant in contemporary Basque. It is the only productive form and the only configuration available for all predicates.

<sup>2</sup> The higher state may be lexicalized by a phonologically null lexical item, or it may be spelled out in the auxiliary. The second option could be perhaps be related to the BE/HAVE auxiliary selection found in Basque. In any case, auxiliary selection is not going to be considered in this dissertation.

<sup>3</sup> The complement of a state will be a nominal in the case that it is lexicalized separately from the state node. See section 1.4.1 for a summary of the proposal about the categorization of Roots.

representation of paths made in Zwart (2005) and Pantcheva (2011), I illustrate the scalar measure of these syntactic objects as follows:

$$(21) \quad kanta(p), handi(p), etxerantz(p)$$

$$\begin{array}{ccccccc} - & + & + & + & + & + & \rightarrow \infty \\ 0 & & & & & & 1 \end{array}$$

$p(0)$  and  $p(1)$  indicate respectively the initial and final points of the measure  $p$ . The minus indicates points which are not inside the denotation of  $\llbracket kanta \rrbracket$ ,  $\llbracket handi \rrbracket$  and  $\llbracket etxerantz \rrbracket$ , and the pluses the points that are within the denotation. The transition from the negative point to the positive one next to  $p(0)$  indicates that these two measures have a lower bound, i.e. they need a minimal transition so that a point is within the denotation. The thickness of the pluses symbols incrementality: a point  $p(i_n)$  is greater than the point  $p(i_{n-1})$ , that is to say, it corresponds to a longer part of the song than  $p(i_{n-1})$  in *kanta*, to a higher degree in the domain of “bigness” in *handi*, and, finally, to a nearer point on the way home than  $p(i_{n-1})$  in *etxerantz*. The presence of  $[\rightarrow \infty]$  shows that the measure has no upper bound. The measure continues to  $\infty$ .

As stated in the definition of Rheme (14), each point of the measure illustrated in (21) is mapped monotonically to a subevent of the event. In this way, a [+incremental] and [–upper bound] measure like (21) gives rise to an atelic dynamic event: an activity in the case of *kantatu* ‘to sing’ and a degree achievement in the case of *etxerantz joan* ‘to go towards home’.

If the measure is [+incremental], [–lower bound] and [+upper bound], the resulting predicate is a telic predicate. This is the case of Rhemes represented by DPs like *aurreskua* (a Basque folk dance which consists of four subsequent parts), a Root like *lehor* ‘dry’ and the terminative path *etxeraino* ‘up to home’. Their scalar path is represented this way:

$$(22) \quad aurrekua(p), lehor(p), etxeraino(p)$$

$$\begin{array}{ccccccc} - & - & - & - & - & - & + \\ 0 & & & & & & 1 \end{array}$$

The upper bound is represented by the final plus, the only point which fits within the denotation  $\llbracket aurrekua \rrbracket$ ,  $\llbracket lehor \rrbracket$  and  $\llbracket etxeraino \rrbracket$ .

In other cases, the measure is [–incremental], but nevertheless [+lower bound] and [+upper bound]. I claim this is the case of the Roots appearing in semelfactive predicates like *bozkatu* ‘to vote’, *salto egin* ‘to jump’ and *txalo egin* ‘to clap’.



$$(23) \quad \text{bozka(p), salto(p), txalo(p)}$$

$$\quad \quad \text{— — + + — —}$$

$$\quad \quad \text{0} \qquad \qquad \text{1}$$

These scales are bi-transitional. They involve a transition from a negative phase to a positive one and a transition from a positive phase to a negative one. Negative and positive phases are the contiguous set of points in the measure having all negative or positive value. The negative points preceding the positive ones are defined as the preparatory steps for voting, jumping and clapping: like putting the ballot inside the envelop in the case of voting, bending the knees to catch momentum in the case of jumping, or raising the hands in the case of clapping. These points are not in the denotation of  $[[\text{bozka}]]$ ,  $[[\text{salto}]]$  or  $[[\text{txalo}]]$  and do not correspond to smaller parts of the voting, jumping or clapping either. The points inside the denotation are limited, e.g. in the case of jumping, they involve the moments where the feet are not touching the ground. Then, there is a transition to a negative phase again, corresponding to the points where the measure continues but does not fall within the denotation, e.g. the moments where the feet touch the ground again in the jumping.

Finally, if the measure is [–incremental], [–lower bound] and [–upper bound], there is not any progression or transition involved. I claim that this is the case of the Root *distira* ‘shine’ and *ama* ‘mother’.

$$(24) \quad \text{+ + + + + + +}$$

$$\quad \quad \text{0} \qquad \qquad \text{1}$$

In this type of measures, monotonicity is not a relevant property, given that all points have exactly the same value and all fall within the denotation of the Rheme. There is no change involved: no transition from a negative phase to a positive one or vice versa, and no increase in the value from one point to another.

As can be seen, some measures are *multivalued*, in the sense that the points that they consist of are positive and negative or are ordered incrementally. Change is an inherent part of these measures. In other measures which I will call *monovalued*, in contrast, all the points correspond exactly to the same value. There is no transition of phase, and no incrementality. All points are the same. This is the case of the last examples mentioned, the measure associated to the Roots *distira* ‘shine’ and *ama* ‘mother’.

Multivalued and monovalued measures affect the temporal interpretation of predicates in a direct way. When a Rheme associated to a multivalued measure is

selected by *proc*, all the different points are mapped to the temporal structure of the process, and this triggers a dynamic interpretation. The time goes along the development of the measure. When a Rheme having a monovalued measure is combined with *proc*, in contrast, an interpretation emerges where the time goes on but there is not any progression in the event. In this way, the predicate is interpreted as eventive and non-dynamic. Following Fábregas & Marín (2012), I will call this kind of predicates D(avidsonian)-states (Maienborn 2005, Rothmayr 2009).

Regarding Rhemes of states, their influence on the aspectual interpretation is slightly different. States are central coincidence heads, and the Rheme objects are the Grounds of these central coincidence relations. Thus, when a Rheme associated to multivalued measure is combined with a state, the result are multiple central coincidence relations. When *proc* selects for a state consisting of multiple central coincidence relations, the change of state meaning arising from this combination is interpreted as gradual. This would be the case of *lehor* ‘dry’ in the predicate *lehortu* ‘to dry’:

- (25) Apurka-apurka lehor-tu da  
 little by little dry-TU be.3sgABS  
 ‘It has dried little by little’

In contrast, if the Rheme of the state is associated to a monovalued measure, the change of state is interpreted as instantaneous, so that the predicates formed this way are necessarily telic, achievements in Vendler’s (1957/1967) terms. This is the case of the predicate *amatu* ‘to become/turn sb into a mother’, built on the Root *ama* ‘mother’.

- (26) (\*Apurka-apurka) ama-tu da  
 little by little mother-TU be.3sgABS  
 ‘She has become a mother (\*little by little)’

As can be observed, several types of syntactic objects can be Rhemes: PPs, quanticized DPs (*aurreskua*) and even Roots (*dantza*, *txalo* etc.).

Roots can be classified in different groups depending on whether they name an Event, a Property or a Thing, and depending on the type of measure associated to them (cf. Harley 2005).

**Table 1.1.** Ontology of Roots

<b>Event naming Roots</b>		
+ incremental	– incremental	– incremental
+ lower bound	+ lower bound	– lower bound
– upper bound	+ upper bound	– upper bound
mono-transitional	bi-transitional	non-transitional
<i>kanta</i> ‘dance’ in <i>kantatu</i> ‘to sing’	<i>bozka</i> ‘vote’ in <i>bozkatu</i> ‘to vote’	<i>distira</i> ‘shine’ in <i>distiratu</i> ‘to shine’
<b>Property naming Roots</b>		
+ incremental	+ incremental	– incremental
+ lower bound	– lower bound	– lower bound
– upper bound	+ upper bound	– upper bound
mono-transitional	mono-transitional	non-transitional
<i>handi</i> ‘big’ in <i>handitu</i> ‘to get bigger’	<i>lehor</i> ‘dry’ in <i>lehortu</i> ‘to dry’	<i>ama</i> ‘mother’ in <i>amatu</i> ‘to become a mother’
<b>Thing naming Roots</b>		
+ incremental		– incremental
– lower bound		– lower bound
+ upper bound		– upper bound
mono-transitional		non-transitional
<i>bazkal</i> ‘lunch’ in <i>bazkaldu</i> ‘to have lunch’, <i>txiza/pixa</i> ‘piss’ in <i>txiza/pixa</i> <i>egin</i> ‘to piss’		<i>izerdi</i> ‘sweat’ in <i>izerdi egin</i> ‘to sweat’

Property naming Roots are combined in syntax with state subevents, whereas Event and Thing naming Roots are combined with process subevents.

I consider that Roots are basic elements, drawn from the open lexicon. Besides, following Marantz (1997 et seq.), I assume that Roots are acategorial in syntax. As I will show in the next section, however, these Roots can be spelled out as nouns, depending on the configuration in which they are lexicalized.

### 1.3. CONNECTION TO LEXICALIZATION AND CATEGORIZATION

#### 1.3.1. Lexicalization and categorization of Roots

From the study of complex unergative predicates, I will conclude that a Root which is spelled out separately from its respective subeventive head surfaces as a nominal (see also Coon 2010 which makes a similar claim for Chol). A Root which surfaces as a nominal has to be case-licensed, so the following generalization can be made:

(27) Generalization on Roots

Roots surface as nominals and need to be case-licensed if they are lexicalized separately from their respective subevent.

This Generalization on Roots explains why complex unergative predicates cannot take an internal object other than the Root. When the Root is lexicalized separately from its subeventive head, it becomes a noun and, as such, it has to be case-licensed. Since there is only one case-assigner available, the higher state (Voice) head, only one object can surface. In morphologically simple predicates, in contrast, the same lexical item (LI) spells out the subeventive head and the Root.

(28) a. *dantza-tu*

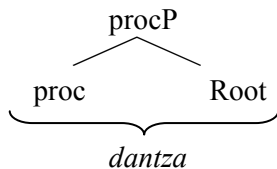

b. *dantza egin*

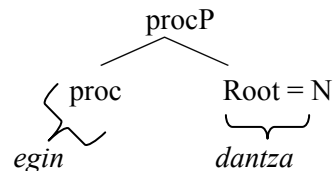

This analysis has interesting implications for the categorization of Roots. It suggests that a Root which is categorized as a nominal is not syntactically defined as a nominal: it is not labeled by a functional *n* head (as it is assumed in DM accounts, e.g. Marantz 1997 2001 2007) and it does not need to have a referential index (cf. Baker 2003). Instead, it points out that the nominal category of Roots emerges as a consequence of the configuration in which it is spelled out. The category N, or the category maker *n*, is not involved in this process (see Déchaine 2005 and Déchaine & Tremblay in prep).

### 1.3.2. No verbal category

Turning to the verbal category, I claim that *V* and *v* are not present in syntax. The formation of location predicates like *etxe-ra-tu* ‘to go/to take sb home’ shows that there is no silent *V* to which the adposition and its complement incorporate (against Hale & Keyser 1993). The LI *-ra-* (usually glossed as the allative adposition) is directly inserted in *proc* precisely because the topological and syntactic structure of *procP* (Ramchand 2008a) and *GoalP* (Pantcheva 2011) are isomorphic. Therefore, *ra* can lexicalize a subeventive head without the need for a silent *V*.

Regarding the verbalizer *v* (Marantz 1997), there is no evidence in Basque that such a head exists. The great majority of predicates in Basque are aligned in the analytic configuration, headed by *-tu* in the infinitive and in the perfect/perfective and *-tzen* (consisting of *-tze-* and the inessive adposition *-n*) in the imperfective. They are not inflected for tense, mood or person/case/number agreement, but only for viewpoint aspect. Tense, mood and agreement morphemes are conveyed in a separate auxiliary. *-Tze* is standardly assumed in Basque linguistics to be a nominalizer, and the suffix *-tu*, which can be considered at first sight “a verbalizer” given that it is used to form predicates out of almost anything, better fits the nominal category, rather than the verbal one (Haddican 2007, Haddican & Tsoulas 2012), as we will see. As for the few predicates that can inflect synthetically, which are, nevertheless, of high frequency, I propose that their “verbness” follows from the fact that they are lexicalized out of the first phase domain, in combination with tense and other inflectional morphology, rather than from the underlying presence of a verbalizer functional head (see, in this respect, Laka 1993b and Arregi & Nevins 2012 for the analytic/synthetic configurations in Basque, Embick 2000 for the categorization of Latin predicates in analytic/synthetic configurations, and Svenonius 2007 who suggests that verbs and adpositions differ in that verbs have tense).

### 1.3.3. Decomposing categories

In this dissertation, I will conclude that there are no lexical categories like *N* or *V* in syntax, or labeling functional heads like *n* or *v*. The categories *N* and *V* are epiphenomenal, derived from the lexicalizing configuration of syntactic objects, and relevant only at a post-syntactic level. This approach to categories takes to its radical conclusion those analytic frameworks which aim at reducing lexical categories to a bare minimum (Déchaine 2005, Déchaine & Tremblay in prep, Kayne 2008, Boeckx

---

2015). Thus, for Kayne (2008) and Boeckx (2015), syntax only provides a two-way distinction within categories: nouns and non-nouns in Kayne (2008) and intransitive and transitive complements in Boeckx (2015). In particular, Boeckx (2015) considers that the two syntactic categories give rise to configurational variants (specializations) post-syntactically, providing all the range of morpho-syntactic categories, e.g. verbs, adpositions, adjectives etc. As I will show, the analysis of categorization made in this dissertation is closely related to the binary approach made in Kayne (2008) and Boeckx (2015), with the difference that, in the present analysis, categories are not defined exclusively in syntactic terms. Instead, categorization is understood as a process determined by both syntactic configuration and the way in which syntactic nodes are grouped in lexicalization.

## 1.4. CONNECTION TO VIEWPOINT ASPECT

### 1.4.1. Viewpoint aspect and categorization

Building on Laka's (1993b) and Arregi & Nevins's (2012) analyses of Basque inflection, I claim that, in the analytic configuration of predicates in Basque, the predicate is spelled out in complement position of the Aspectual head corresponding to viewpoint aspect (Smith 1997[1991]). On the other hand, inspired by Embick's (2000) proposal on Latin analytic/synthetic forms, I claim that this fact makes the predicate surface with nominal category. Embick (2000) argues that when the Root moves up to Asp and no higher, it is spelled out as an adjective, whereas if it moves (together with Asp) to T, it is spelled out as a verb. According to him, in the former case, there is not an adjectivization process involved. Regarding Basque, I claim that in the analytic form, the predicate, originated in the complement position of Asp, is spelled out separately from it, as a nominal. The Asp head is spelled out by the inessive *-n* in the imperfective and by a phonologically null LI ( $-\emptyset$ ) in the perfect.

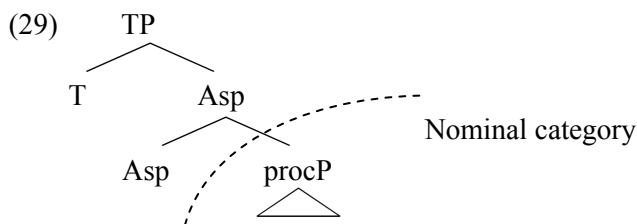

Regarding synthetic forms, I claim that in those cases, Asp is not projected (Laka 1993b). This fact has consequences for both the aspectual interpretation (see Demirdache & Uribe-Etxebarria 2014) and for the lexicalization/categorization of the predicates. When Asp is not present, the predicates can be lexicalized out of the first phase domain, together with tense and other inflectional morphology, and can be realized as verbs.

Note, however, that it is not the case that in all configurations where Asp is not projected the predicate is spelled in the high functional domain. In order for that to be possible, the lexical items (LIs) corresponding to the predicate must be specified to be lexicalized above the first phase domain. These predicates are very few in contemporary Basque, do not have a full productive paradigm, and most of them have meanings associated to viewpoint aspect, modality, motion etc. I argue that all these

aspects of synthetic predicates can be taken as symptoms of their “quasi-functional” nature, using Cardinaletti & Shlonsky’s (2004) term. Thus, I suggest that the LIs used in synthetic configurations –e.g. *oa* of *joan* ‘to go’ and *to/tor* in *etorri* ‘to come’– have a lexical entry with a stored tree containing an additional node X (where X corresponds to the relevant “high” functional head). On the other hand, the LIs of other predicates, such as *maite* ‘love’ of the predicate *maite izan* ‘to love’ do not contain such a node.

(30) *oa* ↔ </oa/, X, conceptual content>

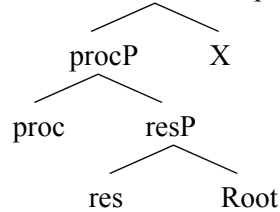

(31) *maite* ↔ </maite/, stateP, conceptual content>

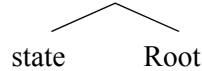

This contrast has a clear consequence in the realization of these predicates. The LI *oa* will lexicalize X, in combination with tense and inflectional morphology, while *maite* will lexicalize only the first phase, in this case, the stateP. *Oa* will surface as a verb and *maite* will be realized as a nominal.

#### 1.4.2. The nature of viewpoint aspect

In this dissertation, I adopt the model of tense and viewpoint aspect developed by Demirdache & Uribe-Etxebarria (2000 2004 2005 2014) where T and Asp are defined as spatiotemporal predicates which order two time intervals: T orders the utterance time (Ut-T) with respect to the assertion time (Ast-T), and Asp orders the assertion time relative to the event time (Ev-T). The ordering can be of precedence, inclusion or subsequence, and these differences yield different temporal and aspectual readings.

(32) a. Retrospective  
AST-T *after* EV-T

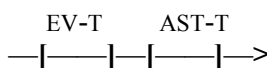

b. Progressive  
AST-T *within* EV-T

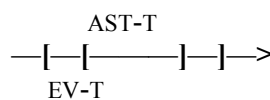

c. Prospective  
AST-T *before* EV-T

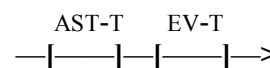



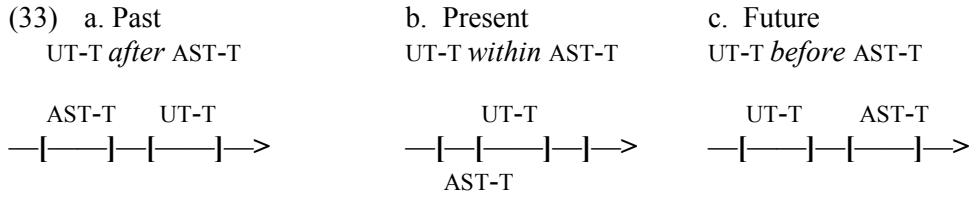

The ordering relations are defined in terms of a basic semantic opposition:  $\pm$  central coincidence (Hale 1984). Present tense or progressive aspect is characterized by a predicate of central coincidence (WITHIN). Past tense or perfect aspect is formed by a predicate of [-central, +centrifugal coincidence], where the Figure is ordered AFTER the Ground, or where the trajectory of the Figure is FROM the Ground. Finally, future tense or prospective aspect is defined by means of a predicate of [-central, +centrifugal coincidence], where the location of the Figure is understood to be BEFORE or TOWARDS the Ground.

I claim that in the perfect, a phonologically null LI ( $-\emptyset$ ) is the exponent of the Asp head *after*, and that, in the imperfective, *-n* is the exponent of the Asp head *within*. There is, nevertheless, an exception to this characterization. When stative (non-eventive) predicates are inflected in the imperfective form, I claim that the inessive *-n* does not spell out the Asp head, but the state subevent itself. Building on Katz (2003), who suggests that Asp has a stativizing function, I argue that states do not need to be combined with Asp. This is because states denote properties of times, rather than properties of events, and as such, they can combine directly with tense.

### 1.4.3. The nominal category of the predicate

In this dissertation, I assume some principles proposed within the Nanosyntax project (e.g. Fábregas 2007, Starke 2009 2014, Caha 2010, Pantcheva 2011). One of the most relevant principles in this analysis is *Phrasal Spell Out*. According to *Phrasal Spell Out*, an LI can lexicalize a non-terminal node. Within this conception of lexicalization, I formulate the Generalization on Roots depicted in (27), repeated here for convenience.

#### (34) Generalization on Roots

Roots surface as nouns and need to be case-licensed if they are lexicalized separately from their respective subevent.

---

This generalization points out that when a Root is spelled out by the same LI which lexicalizes its subevent, the Root will surface as a non-noun, and that, on the contrary, when it is lexicalized separately, it surfaces as a noun. This correlates nicely with the analysis proposed for the predicate and its lexicalization. When the first phase domain is spelled out separately from Asp, it gets nominal category. On the other hand, if it is lexicalized together with another head, namely Asp or T, it surfaces as a non-noun (e.g. adjectival, adverbial or adpositional, or if it is combined with T, as a verb). The replication of the categorization pattern of Roots in the context of T, Asp and the first phase domain indicates that categorization may be a process which is recursively applied in the course of syntactic derivation and lexicalization of syntactic nodes.

## 1.5. OVERVIEW OF THE CHAPTERS

### **Chapter 2: Basic components of events and their arguments**

In this chapter, the background and basic machinery of the proposal are presented. In particular, I identify the components and compositional rules that give rise to the event configuration. I assume that events can be decomposed into processes, states and Rhemes, and that these elements are combined in syntax by means of the operation Merge. On the other hand, I deal also with the introduction of subjects in the subeventive configuration.

### **Chapter 3: The syntax and lexicalization of unaccusative & causative (derived) predicates**

In chapter 3, I address the subeventive decomposition and lexicalization of unaccusative and causative (derived) predicates in Basque. As I show, unaccusative and causative derived predicates are usually built on stems which can occur independently in the language as a noun, an adjective, an adverb or an adpositional phrase, and their use as eventive predicates involves adding the suffix *-tu* to these stems. I propose that, in the case of derived verbs, the stem lexicalizes a state subevent, which, after being selected by process (spelled out by the suffix *-tu*), becomes a result.

### **Chapter 4: Unergative & non-causative transitive (derived) predicates**

The predicates that are analyzed in chapter 4 consist of the process subevent and a Rheme complement. The process subevent and the Rheme are involved in a homomorphic relation, where the structure of the measure denoted by the Rheme is mapped to the temporal structure of the process subevent. I show that, depending on the properties of the measure associated to the Rheme, the resulting predicate can be a durative or semelfactive, telic or atelic. On this basis, I propose an ontology of Roots, where verbal Roots are classified according to the aspects [ $\pm$ incrementality], [ $\pm$ lower bound] and [ $\pm$ upper bound]. Finally, in this chapter, I also address the categorization of Roots. In particular, I propose that when a Root is lexicalized separately from its subevent, it surfaces as a nominal. This analysis of the categorization of Roots

accounts for the fact that morphologically complex unergative predicates cannot take other complements apart from the Root.

### **Chapter 5: Adpositions, events and the verbal category**

In this chapter, I argue that syntactic heads like V and v are not present in Basque analytic predicates. Focusing on location predicates (e.g. *etxe-ra-tu* ‘to go/take sb home’, *ohere-ra-tu* ‘to go/take sb to bed’), I show that Basque location predicates can only be built on GoalPs (Pantcheva 2011), and not on PlacePs, SourcePs or ScalePs. Basing on this restriction, I suggest that location predicates cannot be argued to consist of a silent V to which an adposition has been incorporated. Instead, I argue that the LI *-ra-* (the allative) is directly inserted in the *procP* node. This fact suggests that the *proc* cannot syntactically represent a V head. On the other hand, I show that the suffix *-tu*, which could be perhaps considered a verbalizer in the sense of Marantz (1997), share some distributional properties with nominals –appearing within DPs and PPs–, a fact which suggests that *-tu* predicates fit better the nominal category, rather than the verbal one.

Finally, in this chapter I also consider the implication of the analysis of the categorization of Roots put forward in chapter 3 for the theory of categorization. I show that my analysis of the categorization of Roots predicts correctly when a Root will surface with nominal category also in state subevents.

### **Chapter 6: The boundary between eventivity and stativity**

Chapter 6 deals with the limit between stativity and eventivity. I propose that a central coincidence relation is necessary in order to build a stative predicate, as claimed by Hale & Keyser (2002). Eventivity, on the other hand, emerges when the process head is projected in the structure (Fábregas & Marín 2012). As we will see, these two elements can be combined in the same configuration, and in some cases they trigger stative-like but eventive predicates. Following several recent works (Maienborn 2005 2007, Rothmayr 2009, Fábregas & Marín 2012), I classify stative predicates into two groups: K-states and D-states. Both types of predicates are non-dynamic, and D-states, in particular, involve the projection of the process subevent.

### **Chapter 7: The introduction of the external argument and the interaction between situation and viewpoint aspect**

In this chapter, I continue studying the eventive/stative limit, but, this time, in relation with the head introducing the external argument and the interaction between viewpoint and situation aspect. Basing on the characterization of D-states and K-states made in chapter 5, in this chapter I explain why intransitive K-states are cross-linguistically unaccusative/unergative variable, whereas intransitive D-states are generally unergative.

I make an analysis of the head introducing the external argument (labeled Voice), and more specifically, of its relation with the process subevent. Building on the conception of the initiation subevent made in First Phase Syntax (Ramchand 2008a), I will propose –departing from Kratzer (1996)– that Voice is a stative head. Crucially, its interpretation varies on the basis of the whole first phase configuration. Depending on the context, it can be interpreted as a state or as an initiating subevent. More specifically, when it is combined with *proc*, it will be interpreted as initiation, and the subject in its specifier as an INITIATOR.

### **Chapter 8: Decomposing verbal configurations**

In this chapter, I make an analysis of the different verbal configurations of Basque and of their aspectual interpretation. I argue that the synthetic or analytic form of the predicates is partially related to the aspectual projection responsible for the viewpoint aspect, in line with Laka (1993b), Arregi (2000) and Arregi & Nevins (2012). On the other hand, building on Embick (2000), I suggest that the predicates which are lexicalized in the local environment of T surface like verbs in a synthetic configuration, whereas if they are spelled out in the complement position of Asp, they surface with nominal category and in an analytic configuration. An implication of this proposal is that the majority of what we call “verbs” in Basque is really of nominal category. Only the predicates in the synthetic configuration and auxiliaries have a true verbal category. Since the “verbness” of a predicate is defined in terms of it being lexicalized out of the first phase domain, I ultimately suggest that the verbalizer *v* (Marantz 1997) does not exist in Basque.

## **2. Basic components of events and their arguments**



## 2.1. INTRODUCTION

This chapter is divided into two parts. Section 2.2 will introduce the lexico-semantic background of the analysis that will be presented in the dissertation, and section 2.3, the basic syntactic machinery that will be used.

Firstly, I will review some of the literature which has proposed that events can be decomposed into more basic components, and that these pieces are syntactically represented (e.g. Hale & Keyser 1993). I will mainly focus on the presentation of *First Phase Syntax*, the syntactic domain for event decomposition which has been proposed in Ramchand (2008a). Finally, I will also consider lexicalization, particularly the late insertion approach of lexical items defended in Distributed Morphology (e.g. Halle & Marantz 1994) and Nanosyntax (e.g. Stake 2009 2014).

In the second part of the chapter, I will present the basic assumptions and claims on which the proposal made in this dissertation is built. First, I will identify the components and compositional rules that give rise to the event configuration. I will adopt the view that events can be decomposed into processes, states and Rhemes, and that these elements are combined in syntax by means of the operation Merge. When two subevents are merged, their combination is interpreted as implication (Hale & Keyser 1993, Ramchand 2008a). On the other hand, when a subevent merges with a Rheme, a homomorphic relation is established between them (Ramchand 2008a). Rhemes are syntactic objects which are associated to a measure. As I will show, the temporal properties of events are directly determined by the properties of the measures. Finally, to end this second part, I will deal with the introduction of subjects in the subeventive configuration. Departing from Ramchand (2008a), I will claim that subjects are introduced only in the specifier of state subevents.



## 2.2. BACKGROUND

### 2.2.1. Subeventive decomposition

The idea that predicates can be decomposed into smaller parts is an idea that has been advocated for in early works (among others, Lakoff 1965, McCawley 1968 [apud Dowty 1979], Dowty 1979, Jackendoff 1990, Pustejovsky 1991, Levin & Rappaport Hovav 1995). For example, a predicate like *kill* can be paraphrased as *cause to die*, so that *kill* can be decomposed, on the one hand, into *cause*, and on the other, into *die*. *Die* can, in turn, be decomposed into *become* and into a *state* (of being not alive or dead). Levin and Rappaport Hovav (1995) consider that the four Vendlerian aspectual classes –*activities*, *states*, *achievements* and *accomplishments*– can be classified into four predicate templates and that these templates consist of the basic subevents ACT, STATE, BECOME and CAUSE. As can be seen, some templates are more basic than others. For instance, Levin & Rappaport Hovav argue that some predicate alternations take place by means of template augmentation.

- |     |  |                       |
|-----|--|-----------------------|
| (1) | Templates  |                       |
|     | a. [x ACT <MANNER>]                              | <i>activity</i>       |
|     | b. [x <STATE>]                                   | <i>state</i>          |
|     | c. [BECOME[x<STATE>]]                            | <i>achievement</i>    |
|     | d. [[x ACT <MANNER>] CAUSE [BECOME [x <STATE>]]] | <i>accomplishment</i> |

One of the most basic assumptions of this dissertation is that the decomposition of predicates has a precise syntactic correlate. This view, that we owe originally to the work done by Hale & Keyser (1993 et seq.) has been broadly adopted in many works within the generative syntax (among others, Harley 1995 2005, Mateu 2002 2012, Mateu & Rigau 2002, Cuervo 2003, Folli & Harley 2005, Travis 2000 2005 2010, Ramchand 2004 2008a, Fábregas & Marín 2012).

Hale and Keyser (henceforth H&K) (1993) argued that the argument structure of predicates is determined at a lexical level governed by syntactic principles, called *l-syntax* or *Lexical Relational Structure*. For instance, derived predicates like *shelve*, *dance* and *clear* are formed in that level. According to H&K (1993), the vocabulary items *shelve* and *dance* are not listed in the lexicon twice: once with nominal category, and then with verbal category. In contrast, they argue that the verbal instance

originates at l-syntax, and is syntactically derived from the noun. The same applies to the deadjectival verb *clear*. *Clear* is listed as an adjective in the lexicon, and the verb originates at a syntactic level, in a configuration where a silent V selects for the adjective.

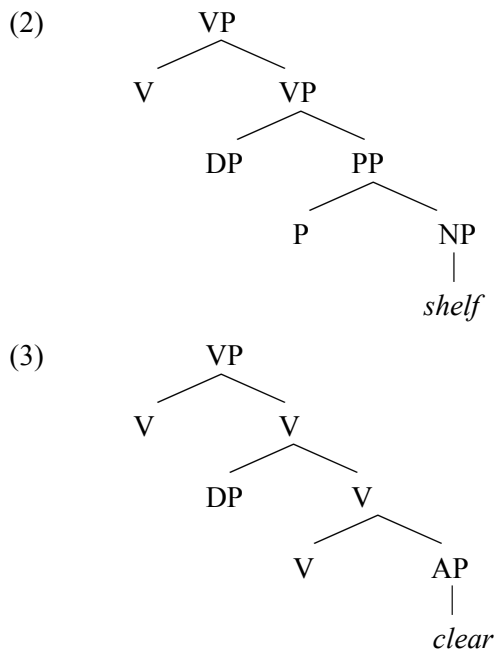

Building on Larson (1988), they claim that verbs have different structural layers and that each syntactic head represents a building block of the event configuration. In the case of *shelve* (2), H&K (1993) argue that the inner V, which is a silent head, selects for a silent P, which in turn, selects for an overt complement NP: *shelf*. The verb *shelve* is formed by means of successive head movement of the noun *shelf*, firstly incorporating onto P and then onto V. In the case of the verb *clear*, the adjective has moved and incorporated onto the silent V which selects for it.

In the model developed by H&K (1993), verb alternations like the causative/anticausative variation are explained in terms of the lexical category and the features associated to the elements on which the predicates are built. As can be seen in the examples below, *dance*, *clear* and *shelve* do not behave alike in the causative construction. The predicate *dance* cannot occur in a structure where the subject is the causer and the internal argument is the undergoing patient the event (4a). *Clear*, in

contrast, can appear in such a configuration (4b), a property that it shares with the denominal *shelve*.

- (4) a. \*Bill danced the poppy  
b. Bill shelved the book  
c. The sun cleared the sky

According to H&K, the fact that these predicates behave differently in the causative configuration is the consequence of their different underlying syntax. To be more precise, they argue that it is due to the lack of an internal subject in the specifier of the inner VP. Whether this structural layer should or should not be projected is directly determined by the lexical categories involved. In the case of *shelve*, H&K (1993) suggest that *shelve a book* is structurally parallel to *put a book on the shelf*. Thus, in the predicate *shelve*, a silent P has been projected. According to them, each lexical category is identified with a particular notional “type” and P denotes an “interrelation”, in this case, subordinate to V. On the other hand, the notional type of V is associated with a (dynamic) event. The syntactic combination of these two notional types gives rise unambiguously to the interpretation where an event implicates an interrelation: “a subject comes to be involved in an interrelation with an entity corresponding to the NP object of the P” (H&K 1993: 71). Thus, it is necessary that an internal argument is projected in the specifier of an inner VP, so that the meaning of P can be interpreted.

A similar situation applies to *clear*. *Clear* is an adjective and adjectives are associated with the notional type of “state”. Combined with V, we get the semantic expression of an event implicating a state, in other words, a change of state. Since the adjective needs to be predicated over an entity, the situation is similar to that of the PP: a subject must be projected in the specifier of an inner VP.

Finally, and contrasting with *shelve* and *clear*, we have the predicate *dance*. This predicate is denominal, but unlike *shelve*, it does not involve the project P. Only NP is projected in the complement position of V.

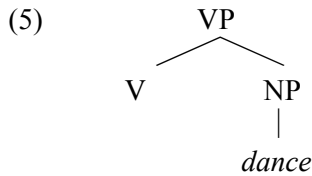

NP is not associated with a predicate, but with an entity. In *shelve* and *clear*, the complement of the inner V is a predicate, and by the principle of *Full Interpretation*, a subject must appear in the inner VP, so that the predication can be realized locally. In *dance*, the complement of V is NP and NP does not force the appearance of an inner subject, since it is not a predicate. Therefore, the impossibility of *dance* to occur in the causative configuration is syntactically motivated by the requirements of the lexical category NP from which it is derived.

In this dissertation, I follow H&K's view on the syntactic decomposition of predicates, although I do not assign to lexical categories the role they perform in H&K's system. In my analysis, predicates are decomposed into subevents (and Rhemes) that are not necessarily related to any particular lexical category.

### 2.2.2. First Phase Syntax

My analysis adopts some aspects of the First Phase Syntax proposed by Ramchand (2004 2008a et seq.). In the First Phase model, a constructionist view of the lexicon-syntax relation is adopted. In this system, it is defended that syntax is built up autonomously as one dimension of meaning. This view contrasts with projectionist approaches, which suggest that the LIs themselves are structured syntactic entities which project their information unambiguously (Chomsky 1995). It also departs from more radical constructionist views (Marantz 1997, Borer 2005b), which posit that LIs are devoid of syntax and that they appear at the bottom of the syntactic tree.

In Ramchand's system, the possible subevents are reduced to three: initiation, process and result. These three subevents are combined in a configuration called *First Phase Syntax*:

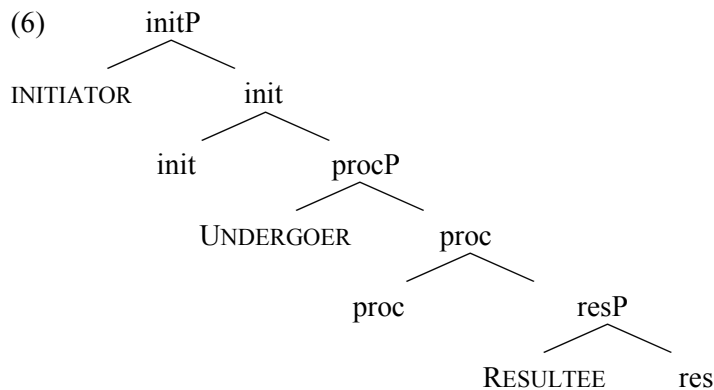

Initiation, process and result combine in this order systematically. In this configuration, initiation and result are both states (different from process), and they obtain their specific interpretation, as initiation or as a result, from their hierarchical position with respect to process.

In the model defended by Ramchand, a LI is considered a memorized bundle of phonological, articulatory, syntactic, conceptual and personal/associational information. Regarding the syntactic information stored, Ramchand argues that the only syntactic specifications included in LIs are category features. These category features represent selectional information and are responsible for associating LIs with the three eventive functional heads. This is the only piece of information necessary to regulate the use of the predicates.

A particular LI can be specified with more than one categorial feature. LIs that contain more than one category feature are associated to more than one syntactic head simultaneously, and this way, a first-phase configuration is built. As an example, consider the predicate *push*. According to Ramchand (2008a: 60), *push* contains the features *init* and *proc*:

(7) a. Push [*init*, *proc*]

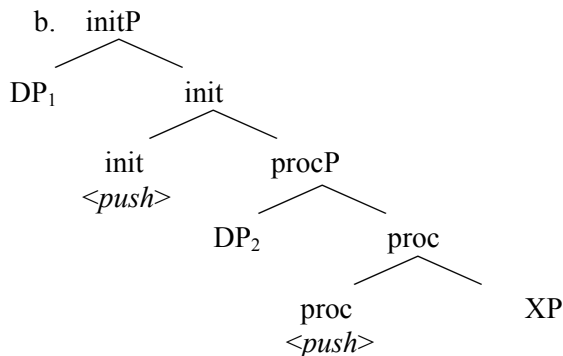

As can be seen, the LI *push* is inserted in the heads of both projections: *init* and *proc*. Having multiple insertions simultaneously, Ramchand drops the assumption that LIs are inserted under a single terminal node (following the principles posited within Nanosyntax, see section 2.2.4.2), without positing a copy operation.

The regulation of the semantic interpretation of the arguments participating in the event is also determined by the category features stored in the LIs. In this system, the specifiers of *init*, *proc* and *res* are interpreted subsequently as INITIATOR, UNDERGOER and RESULTEE. Since a single LI can be inserted in more than one subeventive head, an argument can occupy more than one specifier position. An assumption made in Ramchand, which I do not share in this dissertation, is that all the projections of the first phase require a specifier. In my proposal, the eventive head *proc* does not project one (see section 2.3.4).

Whether a single argument sits in more than one specifier position or, on the contrary, two arguments are required for each position, is also stipulated in each LI. This is made by means of coindexing category labels, as can be seen in the following example:

(8) Dance [*init<sub>i</sub>*, *proc<sub>i</sub>*, N]

The coindexation indicates that the specifier positions of the two projections are filled by the ‘same’ DP. As illustrated in the tree below, the argument sitting the specifier position of the *init* projection and the one in the *proc* projection are the same.

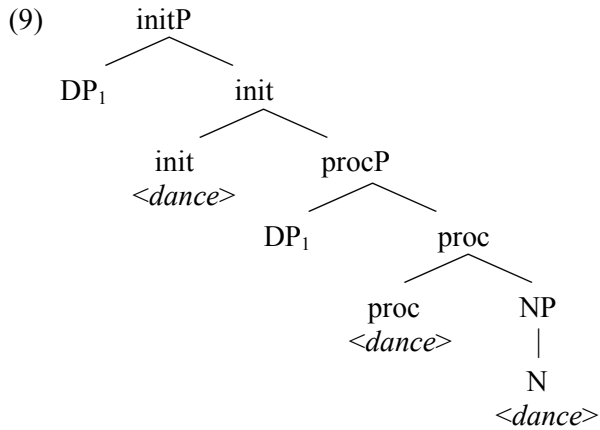

*Dance* belongs to the unergative type analyzed by H&K. As I have mentioned in section 2.1, in the approach adopted in H&K (1993), denominal predicates of this type are considered to be the result of cyclic incorporation of the head of the complement of V into V. Later, in their 2002 work, this approach is abandoned for denominal predicates and a conflation approach is considered, where the phonological content (p-signature) of the complement is copied into V. Finally, both approaches are dropped (H&K 2002 2005), in favor of an account where the lexical item is inserted directly in V-position. H&K (2002 2005) argue that these lexical items are rich enough in order to license covert complements of V. In Ramchand's system, in contrast, since LIs can be inserted in more than one node, the LI *dance* is lexically associated to *init*, *proc* and an N head, where N stands for the Rhematic material of the process event (see section 2.3.1 for an analysis of Rheme objects).

In this dissertation, I will assume some of the concepts of the model developed by Ramchand (2004 2008a), like the decomposition of subevents into states, processes and Rhemes. However, my analysis differs in other aspects from Ramchand's. On the one hand, I do not consider that UNDERGOERS are introduced in the specifier of process, for reasons that will be clarified in section 2.3.4. My view on the insertion of the UNDERGOER is closer to works like Mateu (2002), Cuervo (2003) and Harley (2005).

On the other hand, in my analysis of the analytic configuration of Basque, the lexical items spelling out the predicates are not associated to the *init* head, in line with related approaches like Cuervo (2003) and Harley (2013). As I will argue specially in chapter 6, the head introducing the external argument is a state subevent, which can be

interpreted as initiation if it selects for process, but is not lexically associated to the predicate. Therefore, my analysis of this head is in accordance with those works which suggest that the head introducing the external argument is outside the verbal predicate proper (e.g. Kratzer 1996, Pykkänen 2002/2008, Anagnostopoulou 2003, Collins 2005, Coon et al. 2011, Torrego 2012).

### 2.2.3. Flavors of *v*

The syntactic view of the subeventive decomposition of predicates has been developed by many different authors (e.g. Ritter & Rosen 1998, Travis 2000, Mateu 2002, Oyarçabal 2003, Mateu & Rigau 2002). For instance, several analyses like Harley (2005), Cuervo (2003) and Folli & Harley (2005) have proposed that *v*, the verbalizing syntactic head (Marantz 1997), can come in different flavors and that each flavor corresponds to a different subeventive head:  $v_{\text{CAUSE}}$ ,  $v_{\text{DO}}$ ,  $v_{\text{BECOME}}$ ,  $v_{\text{GO}}$ ,  $v_{\text{BE}}$ . Each kind of *v* is associated with a different meaning and places different restrictions on its subject and complement. For example, according to Folli & Harley (2005), there are two types of agentive light verbs:  $v_{\text{CAUSE}}$  and  $v_{\text{DO}}$ .  $v_{\text{CAUSE}}$  does not necessarily need an animate subject, but its complement has to be a state.  $v_{\text{DO}}$ , in contrast, requires an animate subject and its complement can be an incremental theme. This way, they account for the changes in the clause structure of *consumption* predicates (e.g. Italian *mangiare* ‘to eat’). Consumption predicates usually take an animate subject, like in (10). However, this restriction disappears when the inchoative reflexive *si* is lexicalized as part of the event configuration (11).

- (10) a. Gianni ha mangiato la mela  
Gianni has eat.PST the apple  
‘John ate the apple’  
b. \*La malattia ha mangiato la mela  
The disease has eat.PST the apple  
‘The disease has eaten the apple’
- (11) Il mare si é mangiato la spiaggia  
the sea REFL is eat.PST the beach  
‘The sea has eaten the beach’

Folli & Harley (2005) propose that these different uses of the predicate *mangiare*, the one with the animate subject and the one with *si*, involve different verbalizers in



their syntax. In the examples in (10), where *mangiare* has an animate subject and an incremental theme as complement, they argue that the verbalizer is DO. This light verb requires the subject to be animate. In (11), in contrast, they claim that the verbalizer is CAUSE, and this way, they explain why *mangiare* can combine with an inanimate subject.

I consider that the decomposition of the First Phase and the system of different flavors of *v* are, in the end, similar proposals. A DO verbalizer is parallel to a first phase structure consisting of both *init* and *proc*, where both projections share the same subject, like in *dance*. On the other hand, a CAUSE verbalizer corresponds to a first phase configuration having *init*, *proc* and *res*, where the same DP occupies the specifier position of *proc* and *res*, and a different DP is inserted in the specifier of *init*. In this way, the different flavours of *v* are derived from different combinations of basic subevent types in the First Phase Syntax.

#### 2.2.4. About the lexicalization of predicates

The analysis of the lexicalization of predicates developed in this dissertation is framed within a model where lexical items are introduced post-syntactically and in more than one terminal node, in line with Ramchand (2008a). In this section, I will introduce the late-insertion approach of lexical items adopted in models like *Distributed Morphology* (e.g. Halle & Marantz 1993 1994, Harley & Noyer 1999, Embick & Noyer 2007) and *Nanosyntax* (e.g. Fábregas 2007, Starke 2009 2014, Caha 2010, Pantcheva 2011).

As mentioned above, I assume that phonological material associated with LIs is inserted post-syntactically. Lexical insertion is, thus, independent from syntax. This is a notion which has been developed in the model of Distributed Morphology and in the Nanosyntax project. In both of them, the lexicon, as it was traditionally conceived (Chomsky 1970), is separated in different modules.

On the one hand, morphosyntactic features are considered to be abstract morphemes which are devoid of phonological information and which trigger syntactic operations. They are, thus, present in syntax. Then, in a post-syntactic level, these morphosyntactic features are provided with lexical content, introducing LIs into terminal nodes or non-terminal nodes (see sections 2.2.4.1 and 2.2.4.2). Therefore,

abstract morphosyntactic features and phonological information, which were traditionally located in the lexicon, are separated in the present frameworks.

In both models, the mapping between morphosyntactic features and LIs is expected to be not necessarily one-to-one. For instance, the lack of a straight correspondence between actual words and syntactic features is one of their main tenets. As we are going to see, in each of them, different strategies are proposed in order to account for the mismatches between syntactic features and morphophonological material. Both models share the conception of LIs as relations between a phonological string and morphosyntactic information specifying where that string can be inserted. Nevertheless, they differ as to how this morphosyntactic information is stored and how it is matched.

#### 2.2.4.1. DISTRIBUTED MORPHOLOGY

According to Halle & Marantz (1994) and Harley & Noyer (1999), there are three properties distinguishing Distributed Morphology (DM) from other approaches. The first is *Late Insertion* of phonological expression, an aspect that we have introduced in previous lines (and which it shares with the nanosyntactic approach). The second involves the *underspecification* of LIs (Vocabulary Items in their terms). In DM, it is claimed that a LI does not need to be fully specified to be inserted in a syntactic terminal. This assumption is conveyed in the *Subset Principle*:

(12) The Subset Principle (Halle 1997, apud Harley & Noyer 1999: 5)

The phonological exponent of a Vocabulary Item is inserted into a morpheme... if the item matches all or a subset of the grammatical features specified in the terminal morpheme. Insertion does not take place if the Vocabulary Item contains features not present in the morpheme. Where several Vocabulary Items meet the conditions for insertion, the item matching the greatest number of features specified in the terminal morpheme must be chosen.

According to the Subset Principle, a LI containing the identifying features [A] and [B] can be inserted in a terminal containing the morphosyntactic features [A], [B] and [C]. The LI does not need to supply all the features of the terminal where it is inserted.

However, insertion may not take place if the LI in question contains the feature [D], which is not present in the terminal.

The third property is *Syntactic Hierarchical Structure All the Way Down*. The terminals where LIs are inserted are hierarchically organized in a structure fully determined by syntax. Thus, the resulting phonological outcome is closely tied to syntax. Nevertheless, as pointed out above, syntactic features and phonological material are not involved in a one-to-one relation. In DM, this is explained positing a Morphological Component on the way to the Phonological Form. In this component, the outcome generated by syntax can be further modified by several morphological operations, such as Fission, Impoverishment, local displacement by Morphological Merger and post-syntactic insertion of dissociated morphemes. All these operations respect syntactic hierarchical principles. Let us illustrate morphological operations with an example of Impoverishment (taken from Halle & Marantz 1994: 278-279). Impoverishment consists in deleting one or more than one syntactic feature of a terminal node. Deleting a feature from a terminal has a clear consequence for lexical insertion. Recall that for a LI to be inserted in a terminal, the LI must contain a subset of the features present in the terminal. If one of those features is erased, then, an LI specified with the erased feature –which was in principle appropriate to be inserted in that terminal– is out of the competition. Consider the LIs of category X in (13), which compete for insertion in the terminal X (14).

(13) *Category X*

Vocabulary Item A:  $[F_1, F_2] \leftrightarrow P_A$

Vocabulary Item B:  $[F_1] \leftrightarrow P_B$

(14)        X  
              |  
              [F1,F2,F3]

The competition is won by the Vocabulary Item A because it contains the largest amount of specified features present in the terminal X. However, after the Impoverishment rule (15) applies, the scenario is significantly different:

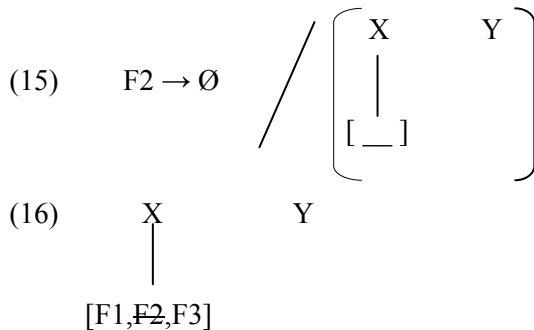

The Impoverishment rule of (15) triggers the deletion of the feature F2 when X is followed by a node of category Y. After this rule is applied, the result of the insertion competition changes. The Vocabulary Item A cannot be inserted, since A is specified with F2 (the erased feature). As a consequence, the Vocabulary Item B will be inserted instead. Thus, a more highly specified Vocabulary Item is not used, in favor of a less specified one.

Halle & Marantz (1994) provide an illustrative example of Impoverishment involving personal clitics in Spanish. The following table shows the paradigm of personal clitics in Peninsular Spanish.

**Table 2.1.** Personal clitics in Spanish (Halle & Marantz 1994: 280)

		3PERS		2PERS	1PERS
		M	F	M/F	M/F
ACC	SG	l-o	l-a	t-e	me
	PL	l-o-s	l-a-s	o-s	n-o-s
DAT	SG	l-e		same as above	same as above
	PL	l-e-s			
REF	SG/PL	s-e		same as above	same as above

Latin American Spanish differs in that the 2<sup>nd</sup> person plural forms are replaced by their corresponding 3<sup>rd</sup> personal forms. Following unpublished work by Harris, they assume that the constituent structure of Spanish clitics is parallel to the structure of

nominals, which consists of a stem, followed by a Theme vowel which in turn, is followed by a number affix.

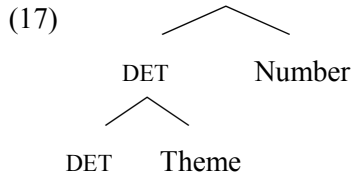

According to Halle & Marantz (1994), the Theme node is introduced post-syntactically, as a consequence of a well-formedness condition. They propose the following list of Vocabulary Items:

- (18)
- |    |  |
|----|--|
|    | DET  |
|    |  |
| a. | /n/ ↔ [1 <sup>st</sup> Person] / governed by [+Pl] |
| b. | /m/ ↔ [1 <sup>st</sup> Person]                     |
| c. | {∅ ↔ [2 <sup>nd</sup> Person] / governed by [+Pl]} |
| d. | /t/ ↔ [2 <sup>nd</sup> Person]                     |
| e. | /l/ ↔ [    ] / <u>    </u>                         |
|    | Case   |
| f. | /s/ ↔ [    ]                                       |

As I have mentioned, the 2<sup>nd</sup> person clitic *os* is not used in Latin American Spanish. Halle & Marantz (1994) suggest that this language variety does not have VI listed in (18c) and, additionally, that it is subject to the following Impoverishment rule:

- (19) [2<sup>nd</sup> Person] ↔ ∅ / governed by [+Pl]

As they point out, without the Impoverishment Rule, the clitic used for the 2<sup>nd</sup> person plural would be /te/, instead of the 3<sup>rd</sup> person clitics. They argue that the presence of the Impoverishment Rule explains the fact that Latin American Spanish lacks 2<sup>nd</sup> person clitics and that it is replaced by 3<sup>rd</sup> person clitics.<sup>4</sup>

<sup>4</sup> The Theme vowels spelled out in each clitic are also explained within the account of Halle & Marantz (1994) but have not been included in the text because it is not relevant for the current discussion. See Halle & Marantz (1994) for a detailed analysis of the lexical insertion in Spanish person clitics.

As can be seen, Impoverishment and other morphological operations mediate the relation between the syntax and the lexicon. What was initially a terminal containing a 2<sup>nd</sup> person plural feature surfaces with a Vocabulary Item realizing no personal features.

The proposals made within Nanosyntax have a slightly different view on the relation between syntax and the lexicon, since they suggest that there is not such a morphological component mediating between them. The analysis made in this dissertation assumes that syntax and the lexicon are directly related, and is based on principles that have been proposed within Nanosyntax.

#### 2.2.4.2. NANOSYNTAX

The Nanosyntax project takes its name from the observation that, in the last decades, syntactic structures are getting bigger and more complex and that, as a consequence, terminals have become smaller than words and morphemes, becoming, actually, submorphemic (Starke 2009). Thus, Nanosyntax shares with DM some considerations about the syntax/lexicon relation, such as *Late Insertion* and *Syntactic Hierarchical Structure All the Way Down*. Nevertheless, it differs from DM in other respects, such as in *Underspecification* and in that morphological operations such as Readjustment rules apply on terminal nodes before spell out.

Within Nanosyntax, the relation between syntax and the lexicon is argued to be straight (Fábregas 2007: 166):

(20) The syntax and the lexicon are directly related

In other words, there is not a morphological component manipulating syntactic features previous to lexical insertion. In contrast, the lexicon is a way to interpret syntax (Starke 2009a). There are not morphological operations such as Impoverishment changing the number of feature present in terminal nodes. For instance, within Nanosyntax, some authors (Fábregas 2007, Pantcheva 2011) have argued for the existence of a universal principle ruling lexicalization which states that all features of a syntactic structure must be lexically realized. This is conveyed in the *Exhaustive Lexicalization Principle*:

## (21) Exhaustive Lexicalization Principle (Fábregas 2007: 167)

Every syntactic feature must be lexicalized.

According to Exhaustive Lexicalization, a feature cannot be deleted from the representation and be left without lexicalization –as it is proposed to happen with Impoverishment. However, note that this does not mean that all features have to be overtly lexicalized. It could be the case that a given feature is spelled out by a phonologically null item.

Regarding Underspecification, in Nanosyntax it is also assumed that the matching between the features in the syntactic tree and those stored in LIs is not one-to-one. Contrary to what is proposed in DM, in Nanosyntax it is argued that lexicalization allows LIs having supersets of the features present in the syntactic structure (Ramchand 2008b, Starke 2009ab 2014, Caha 2009, Pantcheva 2011). Recall that, in DM, the Subset Principle is postulated (see section 2.2.4.1), a principle which makes it possible that a LI specified with a subset of the features present in a node can be inserted in that node.

In Nanosyntax, the opposite relation between the sets of features is considered.

## (22) The Superset Principle (Ramchand 2008b: 121)

The phonological exponent of a Vocabulary item is inserted into a node if the item matches all or a superset of the grammatical features specified in the node. Insertion does not take place if the Vocabulary item does not contain all features present in the node. Where several Vocabulary items meet the conditions for insertion, the item containing fewer features unspecified in the node must be chosen.

According to the Superset Principle, a LI containing the features [A] and [B] cannot be inserted in a terminal node having [A], [B] and [C]. Note that this scenario was permitted with the Subset Principle. On the other hand, a LI specified as [A, B, C] can be inserted in a terminal with only [A] and [B], since the LI in question contains a superset of the features present in the node.

As a consequence of the Superset Principle, a given LI will be able to be inserted in more than one terminal. This is an aspect differentiating Nanosyntax from DM, where LIs are inserted just in one terminal. Recall from the discussion on First Phase Syntax that Ramchand (2008a) also proposes such a lexicalization pattern. In Nanosyntax, a

---

particular LI can lexicalize more than one terminal, and even a non-terminal node, given *Phrasal Spell Out* (Starke 2009 2014, Caha 2009, Pantcheva 2011). This and other properties proposed within Nanosyntax and which are assumed in this dissertation will be presented in chapter 3, section 3.2.



## 2.3. EVENTS AND ARGUMENTS

This section will present the basic machinery on which the analysis of this dissertation is based, regarding (i) the syntactic decomposition of events, (ii) its semantic interpretation and (iii) its interrelation with the arguments involved in the events.

### 2.3.1. Syntactic event decomposition and its interpretation

In this dissertation, it is assumed that the subeventive structure of predicates has a syntactic basis and that the semantic interpretation is read from the syntactic structure in a systematic and predictable way. As I have mentioned, I assume that predicates, whose meaning is compositional, are decomposed into (sub)eventive heads and that each subevent represents a syntactic head. Regarding the different types of subevents, I will assume, in accordance with Ramchand (2004 2008a) that there are basically two types of subevents: processes and states.<sup>5</sup> In (23) we can see the characterization made in Ramchand (2008a: 44).

- (23) a. State(e): e is a state  
 b. Process(e): e is an eventuality that contains internal change

I will slightly depart from Ramchand (2008a) and claim that the process subevent does not necessarily contain change (see Fábregas & Marín 2012). Instead, I assume that the process subevent introduces an event argument (Davidson 1967), and that the state subevent introduces a central coincidence relation:<sup>6</sup>

- (24) a. State(e): e is a central coincidence relation  
 b. Process(e): e is a spatiotemporal entity

In syntax, processes and states are combined by means of the operation *Merge*.

---

<sup>5</sup> This classification of subevent types can be considered similar to Pustejovsky's (1991). The difference is that Pustejovsky (1991) differentiates three event types (processes, states and transitions). In my analysis, the transition event type is derived from the combination of a process and a state subevent.

<sup>6</sup> Central coincidence relations are usually expressed by an adpositional category. Nevertheless, in my analysis, the components which form the event configuration are not directly related to particular lexical categories.

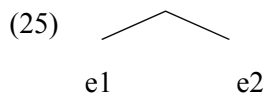

I propose that Merge is read by semantics in two ways: *implication* and *identification*. If the combination is between two subevents (a process and a state), as in (25), Merge is interpreted as implication. On the other hand, if a subevent has merged with an element which is not a subevent, the combination is interpreted as identification.<sup>7</sup>

*Implication* is formulated as follows (H&K 1993, Ramchand 2008):

- (26) Event Compositional Rule (Implication) (Ramchand 2008a: 44)  
 $e = e1 \rightarrow e2$ :  $e$  consists of two subevents,  $e1$ ,  $e2$  such that  $e1$  causally implicates  $e2$ .

According to H&K (1993), this asymmetric semantic relation holds in asymmetric syntactic structures, where a matrix  $V$  governs another  $V$ , the head of its complement.<sup>8</sup>

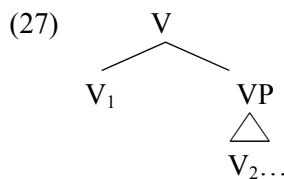

The initiation (*init*) and result (*res*) eventive heads proposed in Ramchand (2004 2008a) are both states. According to Ramchand, their interpretation as *init* or *res* depends on their hierarchical position with respect to the process subevent (*proc*) and on the semantic relation established between them. If the state subevent implicates the

<sup>7</sup> By claiming that Merge is interpreted in two different ways depending on the type of elements that are being combined, I am departing from proposals like the one made in Pietroski (2005) in which it is argued that Merge (*concatenation* in his terms) is systematically interpreted as conjunction.

In favor of the analysis of Merge assumed in this dissertation, we can make the following consideration. Let us assume that the aim of the syntactic operation Merge is to build a more complex object out of a simpler one. The identification (homomorphism) interpretation cannot be generalized to all Merge operations, since if two objects belonging to the same sort are identified, the set resulting from that combination would be exactly the same as one of the objects merged. In this case, Merge would have been vacuous. In order to avoid this, the combination between objects of the same sort must be interpreted in a different way, which here is considered to be implication. I am thankful to Antonio Fábregas for this suggestion.

<sup>8</sup> Note that in my analysis I do not assume the presence of category  $V$  in the subeventive structure.

process, then the state is interpreted as the initiation. In contrast, if the state is implicated by process, then the state gets the meaning of result.

(28) IF  $\exists e1, e2$  [State( $e1$ )  $\cap$  Process( $e2$ )  $\cap e1 \rightarrow e2$ ], then by definition Initiation( $e1$ ).

(29) IF  $\exists e1, e2$  [State( $e1$ )  $\cap$  Process( $e2$ )  $\cap e2 \rightarrow e1$ ], then by definition Result( $e1$ ).

Subevents can combine in syntax with elements which do not constitute by themselves a subeventive head: Rheme arguments. In this case, the Merge operation between the subeventive head and the Rheme argument is interpreted as *identification*. As we have seen, the *init*, *proc* and *res* heads combine via implication –actually, *init* and *res* get that interpretation as a consequence of implication (28)-(29). On the other hand, Ramchand notes (2008a: 46-47) that *proc* can have several other complements apart from *res*, like PPs (30a) DPs (30b) and A(dj)Ps (30c).<sup>9</sup>

- (30) a. John ran towards the park  
 b. Michael ate the apple  
 c. The gap widened

According to Ramchand, these kinds of objects are Rhemes of process. They are not participants of the event and do not constitute a separate subevent. Instead, Ramchand suggests that they combine with *proc* through a relation of event identification. Their role is to further describe and measure the subeventive head they are complementing. As I will show in this chapter, my analysis of Basque deadjectival predicates (similar to the English example in (30c)) departs from Ramchand's (2008a) in that adjectival Roots<sup>10</sup> like *zabal* 'wide' are considered Rhemes of a state subevent, instead of Rhemes of *proc*.

The fact that some events are measured by their complement arguments has been noted in several papers (e.g. Dowty 1991, Krifka 1989 1998, Hay et al. 1999, Kennedy & Levin 2001, Kennedy & McNally 1999 2005, Mateu 2002, Harley 2005, Wechsler 2005, Ramchand 2008a, Beavers 2008, Basilico 2010, Acedo-Matellán 2010). For instance, motion events like that of (30a), incremental theme verbs like (30b) and

<sup>9</sup> In the case of (30c), the LI *widen* is lexicalizing both *proc* and the Rheme in its complement position, or more specifically, *wide* is lexicalizing the Rheme and *-(e)n* the *proc* head.

<sup>10</sup> Note that I am assuming that Roots are a-categorial (Marantz 1997 2001 2007), so that I do not consider that a Root like *wide* is adjectival. Its adjectival properties will derive from the specific configuration in which it is spelled out.

degree achievements like (30c) have been provided a uniform account in terms of a homomorphic relation between the temporal progress of the event and the scalar structure provided by the complement. The scalar structure is associated to the adjectival base in degree achievements, to the PP complement in motion events and to the incremental theme in consumption/creation events (Hay et al. 1999, Levin & Kennedy 2001, Ramchand 2008a, Beavers 2008). In this dissertation, I claim that the homomorphism holds between the subeventive head and the measure associated to the Rheme argument.

According to Hay et al. (1999) and Kennedy & McNally (1999), gradable adjectives are abstract representations of scales, where a scale is a set of points ordered along some dimension. Adjectives denoting an open scale, like *lengthen*, usually give rise to atelic predicates, whereas adjectives denoting a close scale, like *dry*, yield telic predicates. I will come back to the telic/atelic distinction in section 2.3.2.

In the case of motion events, the points on the scale are represented by the positions along the path denoted by the PP. The aspectual properties of the PP are transferred to the event denotation (Verkuyl 1993, Piñon 1993, Jackendoff 1996, Krifka 1998). More specifically, Zwart (2005) proposes that the event is mapped to the path by means of a TRACE function over the set of motion events (Zwart 2005: 756):

$$(31) \quad \llbracket V \text{ PP} \rrbracket = \{e \in \llbracket V \rrbracket : \text{TRACE}(e) \in \llbracket \text{PP} \rrbracket\}$$

The event is in the denotation of the verb and the trace of the event is in the denotation of the PP. Thus, this compositional rule restricts the denotation of the event to those events which have their path in the denotation of the PP. If the PP is unbounded (has a cumulative denotation, according to Zwart 2005), then the whole event gets an atelic interpretation, whereas if it is bounded (non-cumulative in Zwart 2005), the event is telic.

- (32) a. John ran towards the park (\*in two minutes/for two minutes)  
 b. John ran to the park (in two minutes/\*for two minutes)

In incremental theme predicates (30b), the measure is provided by the theme argument. This was formulated by Krifka as the *Mapping to Objects* and *Mapping to Events*, defined in terms of thematic relations.

- (33)  $\forall R [\text{MAP} - \text{O} (R) \leftrightarrow \forall e \forall e' \forall x [R(e, x) \cap e' \subseteq e \rightarrow \exists x' [x' \subseteq x \cap R(e', x')]]]$
- (34)  $\forall R [\text{MAP} - \text{E} (R) \leftrightarrow \forall e \forall x \forall x' [R(e, x) \cap x' \subseteq x \rightarrow \exists e' [e' \subseteq e \cap R(e', x')]]]$

In prose, Mapping to Objects guarantees that all subevents  $e'$  of an event  $e$  with a participant  $x$  in a role  $R$  involve a part  $x'$  of  $x$ . Mapping to Events, on the other hand, ensures that every part  $x'$  of participant  $x$  in a relation  $R$  with a given event  $e$  is involved in a relation  $R$  with a subevent  $e'$ . I propose that a homomorphic relation of this type defines the identification relation, which I propose to hold between a subeventive head and its Rheme complement.

Nevertheless, as noted by Hay et al (1999:15) in a predicate like *mow the lawn* (Dowty 1991), the real measure of the event is not the incremental theme itself, but its area, which is a property of the lawn. Thus, the homomorphism does not hold between the part structure of the argument and the part structure of the event, but between the part structure of the event and the scale or the set of measures associated to a property of the incremental theme. Hay et al. (1999) and Krifka (1989) suggest that the particular dimension or aspect which is relevant for each event (volume, area, surface etc.) is determined by the predicate. On the other hand, Ramchand (2008a) notes that the property may be context-dependent, and that, crucially, it must be monotonic with respect to the extent of the entity involved. Basing on Schwarzschild (2002), Ramchand (2008a) proposes that monotonicity ensures that, in two structured isomorphic domains, the ordering relation is preserved from one dimension to the other.

Thus, for Rheme complements which do not denote scales directly (as gradable adjectives do), firstly, we have to determine a property which is relevant in the context and which is monotonic on the object denoted by the Rheme (Ramchand 2008a: 50).

- (35)  $\prod_C(x)$  is the property determined by  $x$  and the selectional context  $C$ , which is monotonic on  $x$ .

Once the relevant property is determined, a related set of measures,  $d$ , have to be associated to  $\Pi_C(x)$ , by means of the function  $\mu$  (Ramchand 2008a: 50).

- (36) Let  $\mu$  be a function which gives a measure of  $\Pi$ .  
 Let  $D = \{d \in \mu(\Pi(x)): \forall x' \subseteq x \mu(\Pi(x')) = d\}$   
 Let  $\leq$  be a relation that determines a linear order on  $D$ , such that if  $\mu(\Pi(x1)) = d1$  and  $\mu(\Pi(x2)) = d2$ ,  $d1 \leq d2$ , iff  $x1 \subseteq x2$ .

As pointed out by Ramchand (2008a),  $\mu$  and  $\leq$  exist only if the property in question is monotonic with the part-whole structure of  $x$ . I suggest that monotonicity is relevant in the case of PATHS (Rhemes associated to a multivalued measure), but not necessary for non-dynamic Rhemes (Rhemes associated to a monovalued measure).<sup>11</sup> In both cases (dynamic and non-dynamic predicates) an event must necessarily be combined with a Rheme object. Building on Zwart's (2005) TRACE function, I propose the following compositional rule:

- (37)  $\llbracket [\text{subevent } [x]] \rrbracket = \{e \in \llbracket \text{subevent} \rrbracket : \text{RHEME}(e) \in \llbracket x \rrbracket\}$

By means of this formalization, we ensure that all subevents have a rhematic relation with their non-subeventive complements. Now, we need to define the function fulfilled by the Rheme object, which will give us the relation termed as identification. Basing on the concepts that I have presented so far, I suggest that the function associated to the rhematic object is based on the homomorphism between the subevent and its non-subeventive complement. Let the Rheme complement be represented as an abstract measure  $p$ , where  $p(i)$  is a point in  $p$ . Building on Krifka (1989) and Ramchand's (2008a: 51) PATH theta role, I suggest the following formal representation of the Rheme object:

- (38)  $\text{RHEME}(p, e) =_{\text{def}} \forall e' \forall p [R(e, p) \cap e' \subseteq e \rightarrow \exists i [i \subseteq p \cap R(e', i) (\text{mapping to measures}) \cap \forall e' \forall p \forall i [R(e, p) \cap i \subseteq p \rightarrow \exists e' e' \subseteq e \cap R(e', i) (\text{mapping to events})]]$

In prose, (38) means that for all events  $e$ , subevents  $e'$  and measures  $p$ , iff  $p$  is in role  $R$  to  $e$ , and  $e'$  is a subevent of  $e$ , there is a point  $i$  belonging to  $p$  which is mapped

<sup>11</sup> Note that PATH and path are differentiated here. PATH in small capital letters corresponds to Rhemes which are associated to multivalued measures. In other words, PATH corresponds to a dynamic-Rheme. Path in small letters, in contrast, refers to the spatial path.

to the subevent  $e'$ . This corresponds to *mapping to measures*. On the other hand, *mapping to events* means that for all events  $e$ , measures  $p$  and points  $i$ , iff  $p$  is in role R to  $e$  and  $i$  is a point in  $p$ , there is a subevent  $e'$  such that  $e'$  is a subevent of  $e$  and is in role R to the point  $i$ .

In other words, all subevents of  $e$  involve a point  $p(i)$  of the measure, and all the points  $p(i)$  of that measure involve a subevent  $e'$  of the event. This guarantees that the (spatial) structure of the measure denoted by the Rheme is mapped to the temporal structure of the entire event. This relation holds both in dynamic and non-dynamic predicates. Building on Ramchand (2008a), I call the Rhemes associated to dynamic measures PATHS. Now, in order to distinguish between PATHS and non-dynamic Rhemes, I propose that incrementality, transitionality and monotonicity are relevant concepts. The Rhemes which are associated with monotonic and incremental or transitional  $p$ -s are PATHS. On the other hand, Rhemes which are associated with non-monotonic, non-incremental and non-transitional  $p$ -s are non-dynamic Rhemes. I will analyze the different types of Rhemes in section 2.3.2 and 2.3.3.

In the case of state subevents, the measure denoted by the Rheme is mapped to the state subevent. If the state has a PATH as complement, the mapping will yield multiple central coincidence relations. On the other hand, if the state takes a non-dynamic Rheme as complement, the mapping will result in a single central coincidence relation. This difference in going to be explained in more details in sections 2.3.2 and 2.3.3.

The Rhemes of the process subevent will be analyzed in chapter 3. Note that, in that case, the identification relation holds between the process subevent and its Rheme. This means that the structure of the measure denoted by the Rheme of process is mapped to the temporal structure of the process subevent.

Thus, in this system, both processes and states can be combined with PATHS or non-dynamic Rhemes.<sup>12</sup> The four different combinations yield different types of aspectual predicates:

---

<sup>12</sup> This is different from Ramchand's system where processes can only select for PATHS, and states (results) for non-dynamic Rhemes.

**Table 2.2.** Different types of aspectual predicates

RHEMES		
	INCREMENTAL / TRANSITIONAL MEASURE	NON-INCREMENTAL / NON-TRANSITIONAL MEASURE
<i>PROC</i>	dynamic process (activity, accomplishment, semelfactive)	non-dynamic process (d-states)
<i>RES</i>	gradable change of state	instantaneous change of state

In section 3.2, I will explain in more detail the properties of the measures associated to Rhemes.

### 2.3.2. Properties of the measure denoted by Rhemes

As I have mentioned, when two subevents are merged in syntax (a process and state head (39)), the semantic interpretation is that of causal implication. Automatically, the state implicated by the process becomes a result subevent and the predicate is interpreted as a change of state.

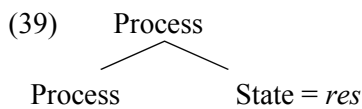

States are subevents which introduce a central coincidence relation between their Figure and their Ground. In this case, the Ground represents the Rheme of the state, since, according to (37), all the non-subeventive complements of a subevent are interpreted as the Rhemes of the subevent.

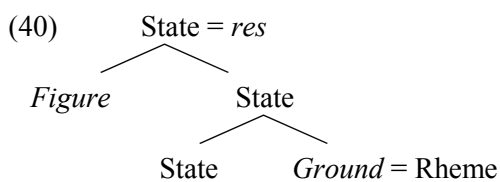

Rhemes are associated to measures, and by identification, the points of the measure are mapped to the internal structure of the event they are complementing.



Precisely because the Ground is the Rheme of the state, I argue, against Ramchand (2008a), that, when *proc* selects for a state, the “change” reading arising from that relation is not necessarily interpreted as instantaneous. Ramchand argues that the transition to the result state is always interpreted as instantaneous, so that all predicates formed as in (39) are necessarily achievements within the Vendlerian (1957/1967) classification. In contrast, I claim that if the Rheme of the state is associated with an incremental scale –in other words, if it is a PATH–, the change can be interpreted as durative. In any case, the Figure undergoing the transition is still in a central coincidence relation with respect to the property denoted by the Rheme, and it is therefore, introduced by the state subevent.

As mentioned in section 2.3.1, a PATH is a Rheme which denotes or gives rise to a scalar and monotonic set of measures related to a property. Consider, for example, the Basque sentence in (41),<sup>13</sup> built on the predicate *joan* ‘to go’ and an approximative allative complement:

- (41) Mikel etxe-rantz joa-n-go da  
 Michael.ABS home-APPROX go-TU-GEN be.3sgABS  
 ‘Michel will go towards home’

Following Swart (2005) and Pantcheva (2011), I represent graphically the path argument as in (42), where the points 0 and 1 signal the initial and the final points of the measure respectively. Each minus and plus symbol indicates a point in the measure (in this case a spatial path): minus indicates the non-location of the point in the denotation of *[[towards home]]* and the pluses the location in the denotation. The contiguous points having all negative or positive value are going to be termed negative and positive phases respectively. The transition from the negative to the positive phase occurring near  $p(0)$  points out that this measure has a lower bound, i.e. it needs a minimal transition so that a point is within the denotation.

<sup>13</sup> This sentence has also a telic interpretation where the subject is understood as leaving a location. The difference can be observed adding the *in* and *for* adverbials.

- |      |   |                              |
|------|---|------------------------------|
| (i)  | Mikel etxe-rantz joa-n-go da bi minute-tan<br>Michael.ABS home-APPROX go-TU-GEN be.3sgABS two minutes-INE<br>‘Michael will leave in two minutes and will go towards home’ | <i>Telic interpretation</i>  |
| (ii) | Mikel etxe-rantz joa-n-go da bi minute-z<br>Michael.ABS home-APPROX go-TU-GEN be.3sgABS two minutes-INSTR<br>‘Michael will go towards home for two minutes’               | <i>Atelic interpretation</i> |

Here I am analyzing the atelic interpretation of the predicate.

$$(42) \text{ towards home}(p)$$

$$\begin{array}{ccccccc} - & + & + & + & + & + & \rightarrow \infty \\ 0 & & & & & & 1 \end{array}$$

The arrow indicates that the scale has no upper bound. The path continues to  $\infty$ . Building on Zwart (2005), I suggest that the denotation of unbounded path complements can be defined by means of directional comparatives:

$$(43) \llbracket \text{towards home} \rrbracket = \{p(i_{n+1}) \text{ is nearer to home than } p(i_n)\}$$

The thickness of the symbols show the incremental nature of the path. Each point in the path is nearer to home: a point  $p(i_n)$  equals its anterior point  $p(i_{n-1})$  plus a difference value (Hay et al. 1999).

Consider now a similar predicate built on the terminative *etxeraino* ‘up to home’.

$$(44) \text{ Mikel } \text{ etxe-raino } \text{ joa-n-go } \text{ da}$$

Michael.ABS home-TERM go-TU-GEN be.3sgABS  
‘Michel will go up to home’

The scale provided by the bound path can be represented as follows:

$$(45) \quad \begin{array}{ccccccc} - & - & - & - & - & - & + \\ 0 & & & & & & 1 \end{array}$$

The plus in the final point  $p(1)$  indicates the location of this point in the denotation of  $\llbracket \text{etxeraino} \rrbracket$ . Thus, terminative paths denote a transition from not being in the denotation (represented by the minuses) to a phase of being in the denotation (represented by the plus). The transition from the negative phase to the positive phase which takes place just before  $p(1)$  indicates that this measure has an upper bound. It needs a maximal transition, so that a point is within the denotation of the measure. The presence of an upper bound makes the scale bounded. It is important to note that there is only one positive point. For instance, Pantcheva (2011) argues that in terminative paths, once the location is reached the path ends.

Building on Pantcheva (2011), the denotation of the terminative path can be defined as follows. Let each point  $p(i)$  be paired with a numerical value obtained by the function  $\text{VAL}(p(i))$  corresponding to the degree of the relevant property. On the

other hand, let  $d$  be a difference value which indicates an indefinite increase in the amount (degree) of the relevant property (Hay et al. 1999).

$$(46) \quad \llbracket \text{terminative } p \rrbracket = \left\{ \begin{array}{l} p(1) \text{ is positive iff} \\ p(1) = p_n, \\ p_{n-1} \text{ is negative.} \\ \text{VAL}(p_j) = \text{VAL}(p_{j-1}) + d \text{ iff } p_j \neq p(1). \end{array} \right\}$$

The first part of this definition states that the penultimate point is negative and that when there is a transition to a positive phase the path ends. The second part states that the numerical value of the points preceding the final point  $p(1)$  –notated as  $p_j$ – are incremental: the degree of the relevant property, in this case the nearness to the ending location, increases from one point to the next one.

Predicates denoting non-spatial properties can also be analyzed in these terms. For instance, a deadjectival predicate like *widen* is interpreted as durative, because its base, the Rheme, denotes a gradable property, a scale of wideness. *Wide* is an open-scale adjective, which means that it is associated with a scale which has no maximal value (Hay 1998, Hay et al. 1999, Kennedy & McNally 1999 2005). Compare it for example with the predicate *dry*, which is based on a closed-scale adjective. If something is dry, it cannot be any dryer, but if something is wide, it still can be wider. This opposition can be graphically captured by the scales presented: I propose that the close-scale associated to *dry* is similar to that of the terminative (45), where the final point  $p(1)$  indicates dryness (= the minimal and the maximal value of dryness).

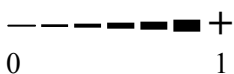
$$(47) \quad \text{dryness}(p)$$

As a consequence of having an upper bound, the predicate *dry* behaves as a telic predicate in the test of the progressive entailment, contrary to *widen*: the perfect of *widen* is entailed by the progressive, whereas the perfect of *dry* is not (Dowty 1979).<sup>14</sup> This test is known as the “imperfective paradox”.

<sup>14</sup> Contrary to what is expected, *widen* is fine with both *in* and *for* adverbials. Hay et al. (1999) suggest that in those cases the telic reading emerges due to a conversational implicature. When the *for* adverbial appears, the implicature is cancelled. My analysis of these facts is presented in section 2.3.3.

- (48) a. The gap is widening  $\Rightarrow$  The gap has widened  
 b. The clothes are drying  $\nRightarrow$  The clothes have dried

This opposition between *widen* and *dry* is due to the fact that the scale of wideness, contrary to that of dryness, does not have an upper bound. Note, however, that *wide* does have a lower bound: a degree in which an object has increased in width is already within the denotation of  $\llbracket wide \rrbracket$ . The presence of a lower bound makes *widen* behave as a telic predicate in other contexts (see Hay et al. 1999):

- (49) The gap is widening significantly  $\nRightarrow$  The gap has widened significantly

For this reason, the graphical scale of *wide* can be illustrated as in (50): apart from  $p(0)$ , all other points in  $p$  are within the denotation of *wide*. As can be seen, the measure denoted by *wide* is similar to that of the approximative.

- (50) wideness( $p$ )  
 $\text{---} + + + + + \rightarrow \infty$   
 0 1

The scale denoted by *wide* and the allative approximative can be defined as follows.

- (51)  $\llbracket \text{wideness/approximative} \rrbracket = \{ \text{VAL}(p(i_n)) = \text{VAL}(p(i_{n-1})) + d \}$

The numerical value of each point in the scale of wideness and the approximative is equal to the value of the anterior point plus an indefinite difference value.

### 2.3.3. Syntactic decomposition and aspectual interpretation

Let us discuss now the syntactic composition and aspectual interpretation of change of state predicates in Basque. I claim that in Basque, Property naming Roots like *handi* ‘big’ are merged with a state subevent, and are thus, the Rheme of the state.

- (52)
- ```

      State
     /   \
  State   Root
  
```



In the predicate *handitu* ‘to grow, to increase’, the fact that the Ground of the state is a Rheme associated to a measure denoting multiple points (where, crucially, each point is different in volume from the rest), the transition to all those points –an interpretation arising from the implication relation holding between *proc* and *res*– makes the predicate be interpreted as durative. The running time of the entire predicate is the sum of all the transitions.

The characterization of Property Roots like *handi* as denoting scalar measures also explains the telic/atelic contrast observed in deadjectival predicates. Open-scale adjectives like *handi* do not have an upper bound, whereas close-scale adjectives like *lehor* ‘dry’ have one (see section 2.3.2). The predicate *handitu* ‘to grow, to increase’ is compatible with both telic and atelic frame adverbials whereas *lehortu* ‘to dry’ is not.

- (57) a. Zuloa bi minutu-z handitu da  
 hole.ABS two minutes-INTR big-TU be.3sgABS  
 ‘The hole has got bigger for two minutes’  
 b. Zuloa bi minutu-tan handitu da  
 hole.ABS two minutes-INE big-TU be.3sgABS  
 ‘The hole has got big in two minutes’
- (58) a. \*Arropa bi minutuz lehortu da  
 clothes.ABS two minutes-INTR dry-TU be.3sgABS  
 ‘\*The clothes have dried for two minutes’  
 b. Arropa bi minututan lehortu da  
 clothes.ABS two minutes-INE dry-TU be.3sgABS  
 ‘The clothes have dried in two minutes’

According to (55) and (56), the final points ( $p(1)$ ) of the measures denoted by the Rhemes are reached in both change of state predicates. The final point in the measure of *handi* ‘big’ does not correspond to the upper bound, so that it is compatible with the atelic temporal adverbial. In the measure of *lehor* ‘dry’ in contrast, the final point corresponds to the upper bound of the scale, so that the resulting predicate is necessarily telic and, as a consequence, incompatible with the atelic adverbial.

Recall that, as mentioned in section 2.3.1, not all Rhemes are PATHS. For instance, the Rheme complements of some state subevents are not associated to incremental or transitional scales, but simply denote a contiguous set of points, where all points correspond to the same value. This type of measure can be called monovalued, in the sense that all points are the same.



### 2.3.4. Arguments: internal and external subjects

Now, I will concentrate on the relation that arguments hold with the eventive heads discussed and how their semantic interpretation is achieved. Following H&K (1993 et seq.), I assume that thematic roles are defined in terms of the structural relations established between the arguments and the syntactic heads.

In the spirit of H&K (1993), I will claim that the internal argument of the predicates explored in this chapter originates in the specifier of a central coincidence head. Recall from the discussion in section 2.2.1, that H&K (1993: 71-77) argue that the principle of *Full Interpretation* guarantees that verbs of change of state or change of location have subjects in the specifier of the inner VP. In both types of predicates, the presence of an internal argument in the specifier of the inner VP is a necessary condition to interpret the complement of V, since both PP and AP need to have a subject to be predicated over.

Building on this idea, I consider that the introduction of the internal subject takes place in the specifier of the state subevent. State subevents denote a central coincidence relation: (i) between an entity and a place, like in spatial predicates; or (ii) between an entity and a property, as in non-spatial predicates. Places and property naming Roots need to have a subject to be predicated over, so that their meaning can be interpreted. Therefore, they have to be put in a central coincidence relation by means of a state subevent. The claim that subjects are introduced in the specifier position of central coincidence heads is a generalization I draw in this dissertation, and as we will see, it can be extended to the external subject.

From this claim, it follows that a subject is not introduced in the specifier of a process subevent. As I commented before, this is an aspect of the present analysis which departs from Ramchand's proposal. In this respect, my analysis is closer to Mateu's (2002) relational syntax of argument structure. According to Mateu (2002: 29), argument structure types can be reduced to three (excluding H&K's 1998 fourth one):

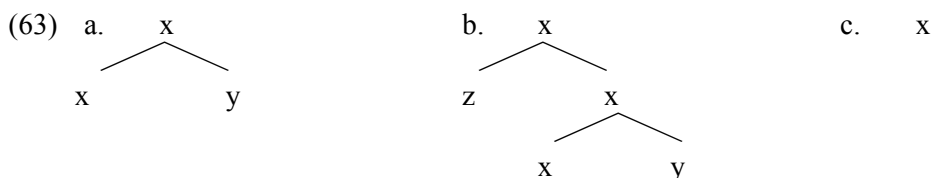



Mateu argues that each argument structure type is directly associated with its corresponding relational semantics:

- (64) a. The lexical head  $x$  in (63a) is to be associated to an eventive relation.  
 b. The lexical head  $x$  in (63b) is to be associated to a non-eventive/spatial relation.  
 c. The lexical head  $x$  in (63c) is to be associated to a non-relational element.

In his terms, the event relation associated to  $x$  in (63a) can be of two types, depending on the presence or absence of a non-derived external argument (EA) in a higher F(unctional) Projection. If there is an EA in the specifier position of FP, the eventive relation will be instantiated as a *source relation* –and the specifier in FP will be interpreted as the *Originator*. If there is no such an EA, then  $x$  will be instantiated as a *transitional relation*. In the latter case, the eventive relation selects for a non-eventive relation (like that of (63b)) and its specifier and complement will be interpreted as the Figure and the Ground. Thus, an unaccusative structure would look like this:

(65) UNACCUSATIVE STRUCTURE

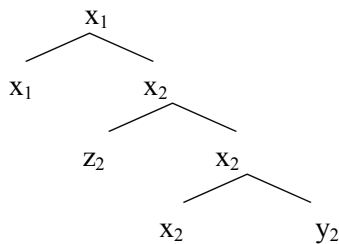

In this structure,  $x_1$  represents the eventive relation, which, in the absence of FP introducing the EA, takes the meaning of transitional relation. It seems to me that  $x_1$  is similar to the *proc* head proposed by Ramchand (2008a), with the difference that *proc* can just have a transitional meaning and that the source relation is conveyed by *init*. The head  $x_1$  selects for  $x_2$ , a non-eventive/spatial relation consisting of a Figure ( $z_2$ ) and a Ground ( $y_2$ ). Process selects for the result subevent, which is basically a state. Both structures seem to be parallel, apart from the fact that  $x_1$  does not take a specifier (that is actually what makes it different from  $x_2$ , recall (63)) while process does take it. In this dissertation I will assume with Mateu (2002) that the eventive relation –headed by process in my analysis– does not take a specifier.

In this respect, this approach is also close to Cuervo's (2003). Cuervo assumes that the verbalizer head can come in different flavors (e.g. Harley 1995);  $v_{DO}$ ,  $V_{GO}$  and  $v_{BE}$ . In a sense,  $v_{DO}$  and  $V_{GO}$  can be considered to be similar to *proc*:  $v_{DO}$  creates activity predicates, where the Root denotes some manner of acting and  $V_{GO}$  is used in predicates conveying movement and "happening" (Cuervo 2003: 7). Within my analysis, in both scenarios the *proc* head is projected –with the difference that in predicates involving a source relation, an additional head above process is projected (like in Mateu 2002). Interestingly, in Cuervo's proposal neither  $v_{DO}$  nor  $V_{GO}$  can introduce subject arguments in their specifier positions.  $v_{DO}$  can have a subject DP but only by means of Voice, and  $V_{GO}$  simply cannot. That is the position that I am taking in this dissertation. The process subevent cannot introduce a DP in its specifier. It can indirectly have it by means of a higher stative subevent, or otherwise, by means of the lower result subevent.<sup>15</sup>

Basically, the reason for not assuming that there is an argument position in the specifier of the process subevent is the necessity to make a clear distinction between internal and external subjects. Consider agentive and unaccusative predicates like *etorri* 'to come' and *heldu* 'to arrive' and *joan* 'to go'.

- (66) a. Gasteiz-era etorr-i naiz  
 Gasteiz-ALL come-TU be.1sgABS  
 'I have come to Gasteiz'  
 b. Gasteizera hel-du naiz  
 Gasteiz-ALL arrive-TU be.1sgABS  
 'I have arrived at Gasteiz'  
 c. Gorbeia mendi-ra joa-n naiz  
 Gorbeia mountain-ALL go-TU be.1sgABS  
 'I have gone to the Gorbea'

These predicates are agentive and do not causativize. Both *etorri* 'to come' and *joan* 'to go' can have a durative interpretation, and, *joan*, can be atelic in some contexts, like with the Route adpositional phrase *aldapan gora* 'up the hill'.

- (67) a. Apurka-apurka etorr-i/joa-n naiz  
 little by little come-TU/come-TU be.3sgABS  
 'I have come/go little by little'

---

<sup>15</sup> Perhaps, *proc* does not introduce a subject participant because it introduces an event argument, and maybe, the event argument saturates the position of a potential subject.

- b. Bi minutuz joan naiz aldapan gora  
 two minutes-INTS go-TU be.3sgABS slope-INE up-ALL  
 ‘I have gone two minutes up the slope’

Ramchand (2008a: 78-79) notes that unaccusative semelfactive predicates like *arrive* and *fall* consist of all *init*, *proc* and *res* subevents. She does not mention, however, gradual (and atelic) unaccusative predicates which cannot causativize. It seems to me that, in her system, the predicates *etorri* ‘to come’ and *joan* ‘to go’ would involve *init* and *proc* subevents, but not *res*, since the events which involve both *proc* and *res* are necessarily instantaneous and telic.<sup>16</sup>

Now, recall that, in Ramchand’s system, unergative predicates like *dance* are also considered to involve an initiation and a process subevent. The subject of *dance* is both an INITIATOR and an UNDERGOER of the process of dancing. Therefore, *dance* and durative (atelic) predicates like *etorri* and *joan* would have a similar event configuration, where a PATH argument is in complement position of *proc*, and a subject fills the specifier of the *proc* and *init* subevents.

My position is rather different. I claim that unergative predicates and agentive scalar unaccusative predicates must be syntactically encoded in different ways. As a matter of fact, in Basque intransitive predicates, whether the subject is introduced in one way or another has consequences for case assignment and auxiliary selection.<sup>17</sup> Thus, my proposal is that only the subjects which are in a central coincidence relation with the predicate are introduced below the projection of the process subevent. Bearing a central coincidence relation does not necessarily imply telicity, as I have explained in section 3.3. Other subjects, like the argument of the intransitive *dance* or the subject of consumption predicates like *eat*, are introduced directly in the specifier of the higher state subevent. In this way, in my analysis, I make a clear distinction between the subjects introduced internally (below *procP*) and the subjects introduced externally (above *procP*).

Regarding theta roles, following the original claim put forward in Hale & Keyser (1993), I suggest that theta roles are derived from the syntactic position occupied by the arguments with respect to event heads. Subjects (both internal and external)

<sup>16</sup> Ramchand (2008) specifically points out that an event consisting of both *proc* and *res* is interpreted as instantaneous if the same LI spells out both heads. In this case, this restriction holds.

<sup>17</sup> As shown in chapter 1, in unergative predicates, subjects are marked ergative and the auxiliary selected is *\*edun* ‘have’. In contrast, in unaccusatives, subjects are marked absolutive (zero mark) and the auxiliary is *izan* ‘be’.

originate as the subjects of state subevents. Thus, originally, these arguments are HOLDERS. However, their interpretation may become more specific as long as the event configuration is built. Thus, a HOLDER argument in a state subevent may become a RESULTEE and an UNERGOER if the stateP is selected by process. Similarly, a HOLDER introduced by a high state subevent may become an INITIATOR if the state selects for a process.

## 2.4. CONCLUSION

I have assumed, following Ramchand (2008a), that there are two event primitives: processes and states. Processes introduce the event argument (Davidson 1967) whereas states denote central coincidence relations. Processes and states combine in syntax by means of Merge, and this operation is interpreted as implication (H&K 1993, Ramchand 2008a). Following Ramchand, I have claimed that depending on the direction of the implication (process  $\rightarrow$  state or state  $\rightarrow$  process), the state subevent is interpreted as a result subevent or as an initiation subevent.

Subevents can also merge with components which do not represent a subevent by themselves. In this case, the non-subeventive complements are identified with the subevent and are, thus, Rheme complements. Rhemes can be associated to scalar or transitional measures (in which case, the Rheme would be a PATH), or can, on the contrary, be associated to non-scalar and non-transitional measures. I have claimed that both process and state subevents can take PATHS or non-dynamic Rhemes, and that the different combinations yield different aspectual classes. I have argued that when the Rheme of a result subevent denotes a multiple-point measure, the entire predicate is interpreted as durative.

Regarding the introduction of arguments, I have claimed that subjects are introduced in central coincidence projections. In the case of internal subjects, they are introduced in the subject position of a state subevent. This implies that only states, and not processes, enter subjects in their specifier (in the spirit of H&K and Mateu (2002) and against Ramchand 2008a).

### **3. The syntax and lexicalization of unaccusative & causative (derived) predicates**



### 3.1. INTRODUCTION

In this chapter, I will analyze the subeventive decomposition and lexicalization of unaccusative and causative (derived) predicates in Basque.

- (1) Mahaia apurtu da  
table.ABS break-TU be.3sgABS  
'The table has broken'
- (2) Jonek mahaia apurtu du  
John-ERG table.ABS break-TU be.3sgABS  
'John has broken the table'

As can be seen, the predicate has the same form in the unaccusative (1) and in the causative (2) form. The only overt difference between the two variants involves the presence of an ergative marked subject in the causative, and the alternation of the auxiliary: *izan* 'be' selected in the unaccusative and *\*edun* 'have' selected in the causative.

In this chapter, derived and underived predicates will be analyzed. Unaccusative and causative derived predicates are usually built on stems which can occur independently in the language as a noun, an adjective, an adverb or an adpositional phrase (see Oyharçabal 2003). Their use as eventive predicates involves adding the suffix *-tu* to these stems in the infinitive (3a) and in the perfect/perfective configuration (3b) and the suffix *-tzen* in the imperfective (3c).

- (3) a. Arropa lehor-tu nahi dut  
clothes.ABS dry-TU want have.1sgERG  
'I want to dry the clothes'
- b. Arropa lehor-tu dut  
clothes.ABS dry-TU have.1sgERG  
'I have dried the clothes'
- c. Arropa eguzki-tan lehor-tzen da  
clothes.ABS sun.INE dry-TZE-INE have.1sgERG  
'The clothes dry in the sun'

This chapter will focus on the [stem-*tu*] form, used in the infinitive and in the perfect/perfective.<sup>18</sup>

Together with derived predicates, this chapter examines also underived predicates: those predicates whose stem is not used out of the predication context. As we will see,

<sup>18</sup> The use of *-tzen* will be discussed in chapter 6 and 7.



the majority of these predicates are also formed adding the suffix *-tu* to the stem (e.g. *etorr-i* ‘to come’, *anima-tu* ‘to cheer up’). The small group which does not take this suffix (either in the infinitive or in the perfect/perfective), called *-tu*-less eventive predicates, will also be addressed.

The outline of the chapter is the following. Section 3.2 will analyze the syntactic decomposition of unaccusative and causative predicates. First, I will address derived predicates (3.2.1), then, underived predicates (3.2.2) and, finally, *-tu*-less eventive predicates (3.2.3). In section 3.3, I will briefly deal with the introduction of the external argument, and finally, in section 3.4, I will present the main conclusions.

### 3.2. UNACCUSATIVE & CAUSATIVE EVENTIVE PREDICATES

Let us start with the syntax and lexicalization of unaccusative and causative derived predicates. Unaccusative eventive predicates are intransitive verbs which convey a change of state, position or location of the subject. This kind of intransitive predicate in Basque is usually uniform: the subject takes absolutive case and the auxiliary selected is *izan* (BE).

- (4) a. Arropa lehor-tu da  
 clothes.ABS dry-TU be.3sgABS  
 ‘The clothes have dried’  
 b. Amets Oierr-engana joa-n da  
 Amets.ABS Oier.ALL go-TU be.3sgABS  
 ‘Amets has gone to Oier’

Most of these predicates, especially the derived ones, can also be used in the causative construction, without triggering any aspectual modification. In that case, the causer subject has ergative marking and the auxiliary selected is *\*edun* (HAVE).

- (5) a. Mikel-ek aulkia apur-tu du  
 Michael-ERG chair.ABS break-TU have.3sgERG.3sgABS  
 ‘Michael has broken the chair’  
 b. Eguzkiak arropa lehor-tu du  
 sun-ERG clothes.ABS dry-TU have.3sgERG.3sgABS  
 ‘(Lit.) The sun has dried the clothes’

In this analysis, I will assume that causative predicates are built on top of the structure belonging to unaccusative predicates, in line with proposals such as H&K (1993 2002), Pylkkänen (2002/2008), Mateu (2002), Cuervo (2003), Oyharçabal (2003) and Ramchand (2008a). Thus, the causative variant of causative alternating predicates is considered here to be more complex than the unaccusative one: a consequence of projecting an additional head in syntax.

I will first focus on derived predicates (e.g. *amatu* ‘to become a mother’, *gorritu* ‘to redden’, *ureztatu* ‘to water’): I will argue that the element on which the predicate is built (Roots like *ama* ‘mother’ and *gorri* ‘red’ or an instrumental PP like *urez-(ta)* ‘water-INSTR+TA’) is lexically associated with a state subevent. In that case, the Root or the PP is the Rheme of the state. When the state is merged with *proc*, it becomes a *res*.

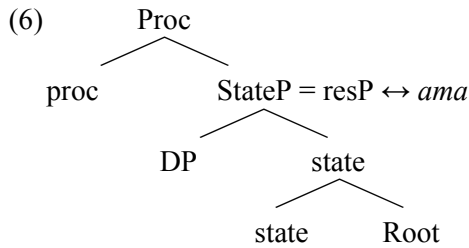

In this section, I will analyze, firstly, derived predicates (3.2.1): predicates that are built on Property naming Roots (3.2.1.1), built on the *-ka* suffix (3.2.1.2), and deadpositional predicates (3.2.1.3). Then, I will address the lexicalization pattern of non-derived predicates (3.2.2), and finally, I will explore some predicates which are not headed by *-tu*, but which behave syntactically and semantically like the rest of the predicates analyzed in this section.

### 3.2.1. “Derived” predicates

I call “derived” those predicates whose stem is used in the language independently, out of the context of the predicate, as a noun, an adjective, an adverb or an adpositional phrase. As I mentioned in the Introduction, the use of the term “derived” is only notational, since I am not making any theoretical assumption about the derivation of these predicates from NPs, A(dj)Ps, AdvPs or PPs (cf. Hale & Keyser 1993). On the contrary, I will claim that, apart from deadpositional predicates, the rest of so called derived predicates are built on a-categorial Roots (Marantz 1997 2000 2008). In the case of the predicates analyzed in this chapter, the Roots belong to the class of Property naming.<sup>19</sup>

It seems that Basque has a considerable number of this kind of predicate. As an approximation, I have taken two samples from the *Corsintax* browser (Landa 2008), which lists the predicates appearing in the corpus *Contemporary Reference Prose* (Sarasola, Salaburu, Landa & Zabaleta 2011, from now on Sarasola et al. 2011), ordered according to frequency rates:<sup>20</sup> the first 220 predicates beginning with *a-* and the first 220 predicates ending with *-tu*. From the 220 predicates beginning with *a-*, 159 are derived (72,3%). From the *-tu* ending 220 predicates, 149 (67,7%). As can be seen, in both lists, the quantity of derived predicates is around 70%.

<sup>19</sup> See chapter 4, sec. 4.2.1.5 for the ontology of Roots proposed in this dissertation.

<sup>20</sup> The *Contemporary Reference Prose* corpus comprises 287 Basque written books and the texts of the newspapers *Berria* and *Herria*, all printed from 2000 to 2006. The corpus has a total of 25.1 million words (<http://www.ehu.eus/en/web/eins/ereduzko-prosa-gaur-epg->).

As I have said, the stems used in derived predicates are used in the language as nouns (such as the stem in *ama-tu* ‘to become a mother’), as adjectives (e.g. the stem of *apain-du* ‘to get ready, to decore’), as adverbs (e.g. *berandu-tu* ‘to become late/make sb be late’) and as adpositional phrases (e.g. *ure-z-ta-tu* ‘to water’). This flexibility observed in the Basque verbal domain lead de Rijk (2008: 151) to make the following statement about the *Magic Suffix -tu* (as he calls it) and the Basque language:

The Basque language owes much of the smooth flexibility that ensures its continued survival as a medium of culture to the remarkable ease with which members of sundry lexical categories can be turned into verbs.

Let us turn now to the syntactic decomposition and lexicalization of the predicates. I claim that in the case of unaccusative and causative predicates, the stems which combine with the *-tu* suffix lexicalize a state subevent. When *-tu* occurs attached to them, a *proc* head is projected above it in the structure, and, as a consequence, the state subevent becomes a result. Let us illustrate this operation with an example: the predicate *hurbil-du* ‘get/put closer’ (7b) which is built on the Root *hurbil* ‘near’. I claim that *hurbil* ‘near’ spells out a stateP. This StateP can occur in isolation in some contexts, as can be seen in (7a). When *-tu* is merged (*hurbil-du* ‘put closer/get closer’) (7b), *proc* is projected above StateP and the relation between both subevents is interpreted as implication.

- (7) a. (Gu) hurbil gaude  
       we.ABS near are  
       ‘We are close’  
       b. (Gu) hurbil-du gara  
       we.ABS near-tu be.1plABS  
       ‘We have got closer’

The internal argument *gu* ‘we’ originates in the specifier of StateP, as required by the state subevent. The state subevent conveys a central coincidence relation between the Figure *gu* ‘we’ and the location *hurbil* ‘close’. The subject *gu* is basically a HOLDER argument, as can be seen in (7a), but when the state becomes the *res* of *proc* (7b), it also becomes a RESULTEE and an UNDERGOER.

Recall from chapter 1 that Roots are associated to measures and that these measures can be defined in terms of being [ $\pm$ incremental], [ $\pm$ lower bound] or [ $\pm$ upper bound]. Depending on these properties, the resulting predicate, in this case, a change of state, can be durative or instantaneous, and telic or atelic. In this case, *hurbil*

is associated to an [+incremental], [+lower bound] and [-upper bound] measure, and as a consequence, the predicate *hurbil-du* is durative and atelic. As can be observed in the examples below, *hurbildu* is fine with the gradual modifier *apurka-apurka* ‘little by little’ and with the atelic frame adverbial.

- (8) a. *Apurka-apurka hurbil-du gara*  
 little by little near-tu be.1plABS  
 ‘We have got closer little by little’  
 b. *Bi minutu-z hurbil-du gara*  
 two mintute-INTS near-tu be.1plABS  
 ‘We have got closer for two minutes’

As noted in chapter 1, in change of state predicates, having a lower bound is sufficient for the predicate to behave like a telic one in some contexts (Hay et al. 1999).

- (9) a. *Bi minutu-tan hurbildu gara*  
 two mintute-INE near-tu be.1plABS  
 ‘We have got closer in two minutes’  
 b. *Apur bat hurbil-tze-n ari gara*       $\Rightarrow$  *Apur bat hurbildu gara*  
 little a near-TZE-INE PROG be.1sgABS little a near-TU be.1sgABS  
 ‘We are getting a bit closer’      ‘We have got a bit closer’

For instance, *hurbildu* can be used with the telic frame adverbial (9a), and behave as telic in the progressive-perfect entailment test if it is combined with *apur bat* ‘a little’ (9b).

### 3.2.1.1. PREDICATES DERIVED FROM PROPERTY NAMING ROOTS

In this section, I will analyze predicates whose stem is used out of the predicative context as a noun, an adjective or an adverb. For convenience, I will use the terms denominal, deadjectival and deadverbial to refer to these classes of predicates, but, as I mentioned before, with no theoretical meaning intended.

In the tables below, I show some deadjectival predicates appearing in the Contemporary Reference Prose (Sarasola et al. 2011), browsed using *Corsintax* (Landa 2008). As can be seen, there are also several deadjectival predicates which are built on complex stems (11). In those cases, the Root is headed by another element:

the relational adposition *-ko*, the property suffix *-dun* ‘who has x’, its negative counterpart *-gabe* ‘devoid, without x’<sup>21</sup> and the superlative *-ago*.

## (10) DEADJECTIVALS

|                                      |                           |
|--------------------------------------|---------------------------|
| argitu ‘to lighten’                  | argi ‘light’              |
| apaldu ‘to lower, to humble oneself’ | apal ‘modest’             |
| arindu ‘to lighten, to lessen’       | arin ‘quick’              |
| agortu ‘to dry, to run out of sth’   | agor ‘dry’                |
| aberastu ‘to enrich’                 | aberats ‘rich’            |
| ahuldu ‘to weaken’                   | ahul ‘weak’               |
| alaitu ‘to cheer up’                 | alai ‘happy’              |
| azkartu ‘to quicken’                 | azkar ‘quick’             |
| apaindu ‘to adorn, to decorate’      | apain ‘elegant’           |
| argaldu ‘to lose weight’             | argal ‘thin’              |
| astundu ‘to become heavy’            | astun ‘heavy’             |
| esnatu ‘to wake up’                  | esna ‘awake’              |
| atzarri ‘to wake up’                 | atzar ‘awake’             |
| moteldu ‘to slow down, to dim’       | motel ‘slow’              |
| gorritu ‘to redden’                  | gorri ‘red’               |
| zuritu ‘to whiten, to peel’          | zuri ‘white’              |
| garbitu ‘to clean’                   | garbi ‘clean’             |
| zikindu ‘to get dirty’               | zikin ‘dirty’             |
| ilundu ‘to darken’                   | ilun ‘dark’               |
| askatu ‘to undo, to liberate’        | aske ‘free’ <sup>22</sup> |

## (11) COMPLEX DEADJECTIVALS

|                                                                                            |                                        |
|--------------------------------------------------------------------------------------------|----------------------------------------|
| ahaldundu ‘authorize, empower’                                                             | ahal ‘power, authority’, -dun ‘having’ |
| areagotu ‘to increase, to intensify’                                                       | are-ago ‘(even) more’                  |
| betikotu ‘to make last forever’                                                            | beti-ko ‘always-ko’                    |
| etxekotu ‘to familiarize, to get used to’                                                  | etxe-ko ‘home-ko’                      |
| euskaldundu ‘to bring to Basque, to become Basque speaker, make people Basque speakers...’ | euskal ‘Basque’, -dun ‘having’         |

<sup>21</sup> In chapter 5, sec. 5.4, I will claim that *gabe* is an adposition, similar to the English *without*. Here, I have just noted that X-*gabe* elements (e.g. *etxe-gabe* ‘homeless’, *itxura-gabe* ‘deformed, nonsensical’ are adjectives. In this sense, I follow Mateu (2002) in claiming that adjectives are decomposed into a relational element (overtly spelled out by *gabe* in this case) and a non-relational element (e.g. *etxe* ‘home’ and *itxura* ‘form, shape’).

<sup>22</sup> In this analysis, I am not taking into account the phonological change of some final vowels [some *e/o/u* → *a*] occurring from the “adjective”/“noun” to the verbal stem (e.g. *aske* ‘free’ → *askatu* ‘to undo, to liberate’) (see Artiagoitia 2004, who proposes that this fact points out that the adjectivizing suffix *-garri* [similar to, but not the same as *-able* in English] attaches to verbal bases, rather than to nominal/adjectival bases. In this dissertation, I do not address the analysis of *-garri*, but it seems to me correct say that the head spelled out by *-garri* must select for a subevent rather than to a bare Root. This and other issues related to *-garri* and other adjectivizing suffixes like *-kor* must be studied in further research.

|                                       |                                            |
|---------------------------------------|--------------------------------------------|
| duntu 'to appropriate, become rich'   | X-dun 'who has X, having X'                |
| etxegabetu 'to evict'                 | etxe 'house', gabe 'lacking'               |
| gutxiagotu 'to reduce, diminish'      | gutxi 'few', -ago (superlative)            |
| larriagotu 'to aggravate, get worse'  | larri 'serious, grave', -ago (superlative) |
| lotsagabetu 'to become insolent/rude' | lotsa 'shame', gabe 'lacking'              |
| itxuragabetu 'to disfigure, deform'   | itxura 'form, shape', gabe 'lacking'       |
| zordundu 'to get into debt'           | zor 'debt', -dun 'having' (in debt)        |

Regarding denominal predicates, I have classified them in two groups: (i) those built on Roots which name a property of individuals, and (ii) those built on Roots denoting a property of psychological or physiological states. The examples have been taken from the *Corsintax* browser and from de Rijk (2008: 152).

(12) PREDICATES HAVING ROOTS NAMING PROPERTIES OF INDIVIDUALS

|                                       |                         |
|---------------------------------------|-------------------------|
| atxilotu 'to arrest'                  | atxilo 'prisoner'       |
| adiskidetu 'to (be) reconcile(d)'     | adiskide 'friend'       |
| alargundu 'to be widowed'             | alargun 'widow/widower' |
| amorostu 'to get in love'             | amoros 'lover'          |
| apaiztu 'to ordain, become a priest'  | apaiz 'pastor'          |
| gizondu 'to become incarnate, mature' | gizon 'man'             |
| amatu 'to become a mother'            | ama 'mother'            |
| mutildu 'to become a lad/boy'         | mutil 'boy'             |
| apurtu 'to break'                     | apur 'piece'            |
| arautu 'to regulate'                  | arau 'rule'             |
| ahitu 'to get tired'                  | ahi 'mush, porridge'    |

(13) PREDICATES HAVING ROOTS NAMING PSYCHOLOGICAL OR PHYSIOLOGICAL STATES

|                                   |                                  |
|-----------------------------------|----------------------------------|
| arduratu 'to bother, to worry'    | ardura 'responsibility, concern' |
| atsekabetu 'to (get) upset'       | atsekabe 'annoyance'             |
| aspertu 'to (get) bored'          | asper 'boredom'                  |
| beldurtu 'to (get) frighten(ed)'  | beldur 'fear'                    |
| damutu 'to regret'                | damu 'repentance'                |
| dolutu 'to regret, to feel sorry' | dolu 'mourning'                  |
| egarritu 'to become thirsty'      | egarri 'thirst'                  |
| gosetu 'to become hungry'         | gose 'hunger'                    |
| grinatu 'to become passionate'    | grina 'passion'                  |
| haserretu 'to get angry'          | haserre 'anger'                  |

The majority of these denominal and deadjectival predicates have a similar syntactic decomposition and lexicalization patterns. As an example, let us analyze the

sentence in (14) with the predicate *amatu* ‘to become a mother’. I consider that *ama* ‘mother’ is a LI lexicalizing a Root and a state node (15a),<sup>23,24</sup> where the internal subject takes the specifier position of the state subevent. That a LI can spell out more than one node is possible in a model where syntax is a pre-lexical component and where the lexicon is a way to interpret syntax, as the *Nanosyntax* framework. As we have seen before, within this view, it is considered that syntax operates only with features and that LIs are inserted post-syntactically (a property defended also in Distributed Morphology, see section 2.2.4.1).

When *-tu* selects for the state, a *proc* head is projected, and the state turns into a result phrase (15b).

- (14) Ane ama-tu da  
 Ane.ABS mother-TU be.3sgABS  
 ‘Ane has become a mother’

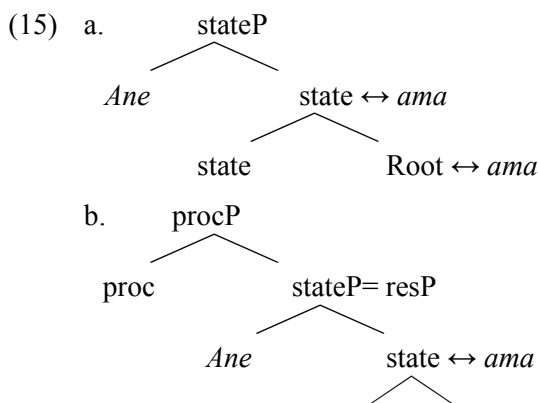

Recall that I assume that there are two types of events: states and processes. The latter are subevents which introduce an event argument.<sup>25</sup> Following Ramchand (2004 2008a), I claim a state subevent is interpreted as a result when it is implicated by a process subevent:

- (16) IF  $\exists e_1, e_2$  [State( $e_1$ )  $\cap$  Process( $e_2$ ) &  $e_2 \rightarrow e_1$ ], then by definition Result( $e_1$ ).

<sup>23</sup> Note that I am not claiming that the LI *ama* always spells out a state node. Assuming the Superset Principle, *ama* can be spelled out in another syntactic context. It can lexicalize a Root headed by a D, for example, and in this case, there would not be a state node projected.

<sup>24</sup> I am assuming that lexical and functional nodes can be lexicalized together.

<sup>25</sup> Note that Ramchand (2008a) claims that process is a subevent conveying internal change. My position is different, since I claim that process can also occur in non-dynamic predicates (see Fábregas & Marín 2012 in this respect).



Based on this, I propose that the state lexically associated to *ama* remains a state until *proc* is projected above. When *proc* selects for the state subevent and their relation is established in terms of implication, the state becomes a *res*.

On the other hand, to state the part of the structure which *-tu* lexicalizes is not an easy matter. Looking at these types of predicates, it seems that *-tu* spells out at least the process subevent. Additionally, as I will discuss in chapter 4 and chapter 7, it is also related to viewpoint aspect and infinitive morphology. Since *-tu* has the ability to turn its complement into a predicate, someone can argue that *-tu* is a verbalizer, in the sense of Marantz (1997). Nevertheless, in chapter 5 I will show that *-tu* fits better the nominal category, rather than the verbal one. For this reason, for the moment I will just assume that *-tu* spells out both a little *n* node and the *proc* node.

- (17) Ane ama-tu da  
 Ane.ABS mother-TU be.3sgABS  
 ‘Ane has become a mother’

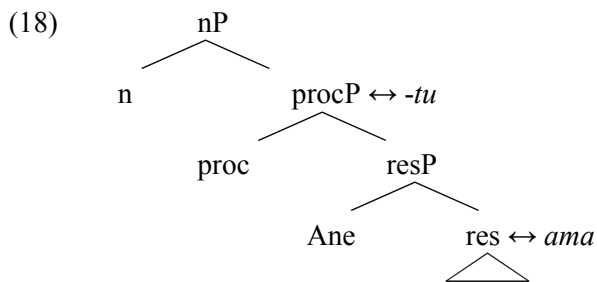

The configuration where both LIs (*-tu* and *ama*) are lexically inserted is specified in their lexical entries, in the form of a subtree.

- (19) *-tu* ↔ < /tu/, nP >
- 
- ```

graph TD
  nP --> n
  nP --> procP
  procP --> proc
  
```

In the Nanosyntax framework, it is assumed that the lexicon contains subtrees, together with phonological and conceptual information, and that lexicalization is a post-syntactic process where lexical subtrees match the trees constructed in syntax (e.g. Starke 2009, Caha 2010). I assume that LIs consist of < phonological information, syntactic tree, conceptual information >, following Starke (2009).

As I have mentioned previously, the LI *ama* ‘mother’ is lexically specified with a Root and a state node. The Root belongs to the class of Property naming Roots, and these Roots combine in syntax with states.

- (20) *ama* ↔ < /ama/, stateP, (conceptual content) >.
- ```

      / \
     /   \
state     Root

```

Another option would be to argue that *ama* is also lexicalizing *proc*, and that *-tu* is just paired with the node n. Nevertheless, I do not think that that is the case. Imagine that we make up a new predicate like *mahai-tu* (‘table-*tu*’). The process of adding *-tu* to form a new predicate is so productive, that any Basque speaker would understand the meaning of this new predicate: ‘to become a table or turn sb or sth into a table’. Clearly, nobody would state that the vocabulary item *mahai* ‘table’ has *proc* as one of its lexical features. Instead, it gets the meaning of a *proc* subevent only when it is combined with *-tu*. Any Property naming Root selected by *-tu* becomes a change of state, as depicted in (15).

More things have to be clarified in order to account for the lexicalization pattern of predicates such as *amatu* ‘to become a mother’. To begin with, the actual order of LIs has to be explained. As I showed in the tree (15), I assume the *Antisymmetry of Syntax* proposed in Kayne (1994), which states that syntax is head-initial and that phrases which do not show the specifier-head-complement order have undergone movement. This is also the view adopted in works done within Nanosyntax.

In the syntactic tree that I posited in (15), the linearized order of features is the following:

- (21) [ n [ proc [ res ] ] ]

Nevertheless, according to the lexical pairing between features and LIs proposed so far, the surface structure corresponds to:

- (22) res (proc / n)  
*ama tu*

I consider that in the lexicalization process, several movement operations have taken place, and that as a consequence we have the surface order portrayed in (22). In order to explain those movements, I rely on several principles. First, I assume the

Superset Principle, as presented in chapter 2, sec 2.2.4.2. Here, I show the version of the principle in Pantcheva (2011).

(23) The Superset Principle (Pantcheva 2011: 122)

A vocabulary item matches a node if its lexical entry is specified for a constituent containing that node.

Consider the LI  $\alpha$  with the following lexical entry:

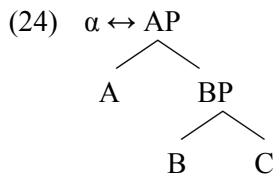

Lexical entries contain trees and this, together with the Superset Principle, enables a lexical item to spell out more than one node and even a non-terminal node. The lexical item  $\alpha$ , depicted in (21), spells out the whole AP. This is formulated as Phrasal Spell Out.

(25) Phrasal Spell Out (Pantcheva 2011: 106)

Lexical insertion can target phrasal nodes.

It is also assumed that lexical insertion proceeds cyclically, after every external Merge.

(26) Cyclic spell out (Pantcheva 2011: 129)

Each step of External Merge is followed by lexical access. There is no lexicalization cycle after Internal Merge.

Imagine that we have a syntactic structure like (27). According to the Superset Principle, the lexical item  $\alpha$  can be paired with it, since it contains a part of the lexical tree of  $\alpha$ .

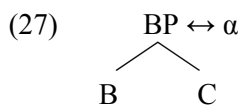

When A merges with BP, a structure identical to that stored in the lexical entry of  $\alpha$  will be created. In such a case, lexical insertion will proceed again and  $\alpha$  will be paired with AP.

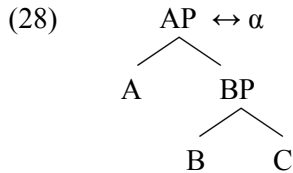

It is assumed that previous spell-outs, like that of BP, are overridden (Caha 2010, Pantcheva 2011). Since lexicalization proceeds bottom-up, the biggest match will always win over the smaller one.

Let us come back to the lexicalization of *amatu* ‘to become a mother’. I assume that when *proc* merges with the state, the latter becomes a *res*. The LI *ama* is paired with *resP*.

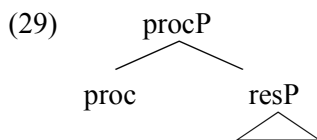

Then, lexical insertion arrives at *proc*. *Proc* is spelled out by the *-tu* suffix but the lexical entry of *-tu*, repeated below, does not match the syntactic tree, since in (29) *procP* contains *resP*.

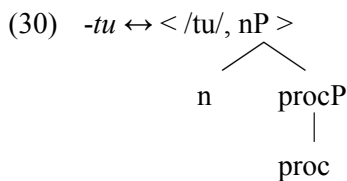

Apparently, this problem can be resolved in two ways. One is to state that the head *proc* does not get lexicalized. However, this option is excluded according to the principle of *Exhaustive Lexicalization* (Fábregas 2007, Ramchand 2008b, Pantcheva 2011).

(31) Exhaustive Lexicalization (Ramchand 2008b: 122)<sup>26</sup>

Every node in the syntactic representation must be identified by lexical content.

Exhaustive Lexicalization rules that every syntactic feature has to be lexicalized. Thus, the head *proc* has to be somehow spelled out. There is a potential candidate to lexicalize *proc*, that is, *-tu*, but its lexical entry only contains one of the daughters of the syntactic structure of (29). It contains *proc*, but not *resP*. Caha (2010), building on unpublished work by Starke, proposes that, in a context where the insertion of a LI in a phrasal node is prevented by the presence of a sub-constituent, that sub-constituent must be evacuated, in order for phrasal spell out to occur. This operation is formulated as the *Spell out driven movement* (Starke 2014, Caha 2010):

## (32) Spell out driven movement (Caha 2010: 22)

In case a phrasal node can be spelled out after evacuation of a sub-constituent, then evacuation takes place.

This type of evacuation movement is the second (and best) option to get *proc* lexicalized. Caha (2010) bases this claim in the realization of case endings as prepositions or suffixes cross-linguistically. He argues that the different realization of a form as a preposition or a suffix, on the one hand, and synthetic/analytic, on the other hand, is the consequence of lexical specifications: specifications to spell out just terminals or, on the contrary, to spell out phrasal nodes. Let us illustrate this claim with examples. Caha (2010) proposes that there exists a universal hierarchy of case heads (33) and that the cross-linguistic variation is reduced to the lexical entries realizing those heads.

## (33) The preposition/suffix hierarchy (Caha 2010: 7)

- a. If the expression of a particular case in the Case sequence (below) involves a preposition, then all cases to its right do as well.<sup>27</sup>
- b. The Case sequence: NOM – ACC – GEN – DAT – INS – COM

<sup>26</sup> Here I show the version of the principle offered in Ramchand (2008b), but see the version of Fábregas (2007) in chapter 2, sec. 2.2.4.2.

<sup>27</sup> The reader must note that the ordering sequence considered is the one in (33b), and not the syntactic sequence illustrated in (34).

According to Caha, the case heads in the hierarchy are organized syntactically, related to each other by a containment relation:

$$(34) \left[ {}_{\text{com}} F \left[ {}_{\text{ins}} E \left[ {}_{\text{dat}} D \left[ {}_{\text{gen}} C \left[ {}_{\text{acc}} B \left[ {}_{\text{nom}} A \text{ DP } \right] \right] \right] \right] \right] \right]$$

The variation attested in the realization of these case heads is the result of various movements, triggered by the need to lexicalize all the features. Let us analyze this with examples from various languages (data taken from Caha 2010).

Note that, in the functional sequence depicted in (34), the genitive case contains the accusative and that the dative case contains both the genitive and the accusative. This containment relation is attested in several languages. For example, in English (35a), the expression of the genitive case includes the presence of the DP case marked with accusative case. In Arabic, nominative, accusative and genitive are suffixal, but dative, in contrast, involves a preposition which combines with a noun ending with genitive (35b). Finally, in Ingush –an ergative language– the dative case marking includes the genitive suffix (35c).

- |      |                   |                          |
|------|-------------------|--------------------------|
| (35) | a. of him         | <i>English. Genitive</i> |
|      | b. li muhammad-in | <i>Arabic. Dative</i>    |
|      | DAT Muhammad-GEN  |                          |
|      | ‘to muhammad’     |                          |
|      | c. kuotam-a-a     | <i>Ingush. Dative</i>    |
|      | hen-GEN-DAT       |                          |
|      | ‘to the hen’      |                          |

The examples are in accordance with Caha’s (2010) hierarchy. The accusative seems to be contained within the genitive, and the genitive within the dative. These trees represent the lexicalization of the English and Arabic examples.

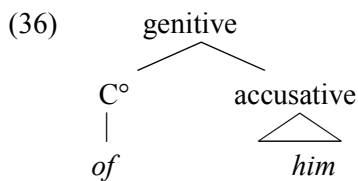

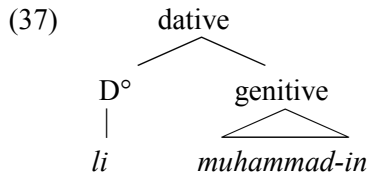

Consider now the Ingush example. Caha proposes that in Ingush, the *-a* suffix realizing the genitive is a LI spelling out the genitive phrasal node. This phrasal node includes the accusative and the nominative, so that it is a synthetic form. This is the lexical entry of *-a*.

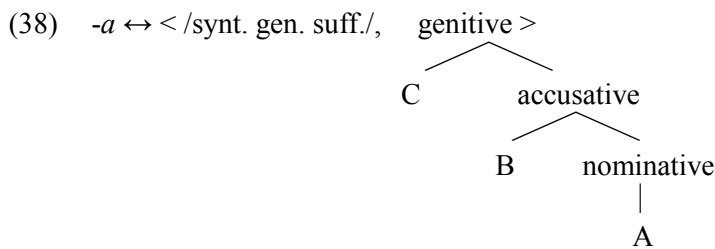

When nominative is merged, the lexicon is accessed, by Cyclic Spell Out. The LI *-a* can be inserted in the nominative node, but for that to be possible, the DP has to be evacuated, since the node DP is not present in the lexical entry of *-a*. Thus, the DP moves to the left of the nominative head, and *-a* is inserted in the nominative node. The same operation is repeated with the lexical insertion of *-a* in the accusative and in the genitive nodes. The DP moves cyclically.

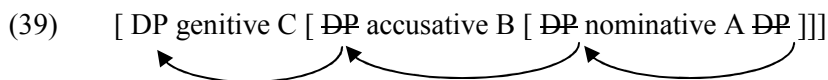

Then, D is merged and projects the dative node. Lexical insertion proceeds again. According to Caha (2010), the LI spelling out the dative node looks like this:

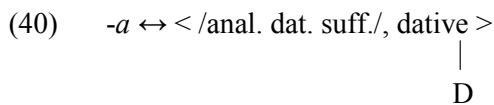

In order to spell out the dative node, an evacuation movement has to take place again. However, this time, the whole genitive node is pied-piped above the dative node. In this way, the LI *-a* realizing the dative node imposes its requirements on the structure, and creates a configuration where the dative node contains only D. This is illustrated in the following tree:

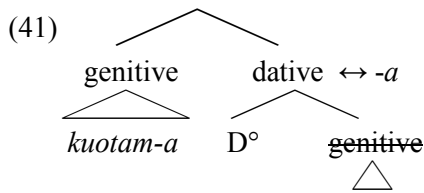

These evacuation movements render the forms and the order we see in the surface: *kuotam-a*<sub>GEN</sub>-*a*<sub>DAT</sub>. All these operations were triggered by the insertion of LIs, which were specified to be matched with phrasal nodes. The presence of some sub-constituent, like the DP within the nominative, accusative and genitive nodes, and the whole genitive node within the dative node, were obstacles for the insertion of the LIs in the nodes, and thus, were necessarily evacuated. The DP has been cyclically moved throughout all the nodes, and the genitive node has been pied-piped to the left of the dative node.

Let us come back again to Basque. *Proc* is merged into the structure. This constitutes a case of external Merge, so that it follows a round of lexical access (recall Cyclic Spell Out (26)). Then, lexical insertion of *-tu* in *proc* takes place and this insertion triggers the evacuation movement of *resP*. *resP* is extracted and merges above *procP* as an adjunct. Since traces are overridden in lexicalization, *-tu* can be paired with the lowest node *proc*, because it does not have any feature other than *proc*.

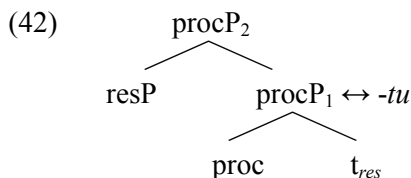

Then, *n* is merged to *procP*, and the lexicon is accessed again.

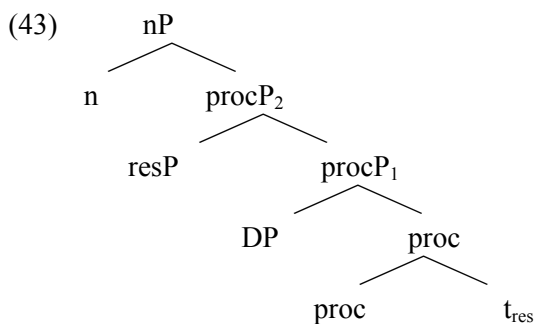



Little *n* has a potential candidate for lexicalization, *-tu*, but recall that for that to be possible, *n* must contain only [*procP* [*proc*]]. As can be seen, in the structure (43), *n* contains both *procP* and *resP*. *-Tu* is inserted in *nP* and this triggers the application of another spell out driven movement. *ResP* is evacuated, this time, above *n*.

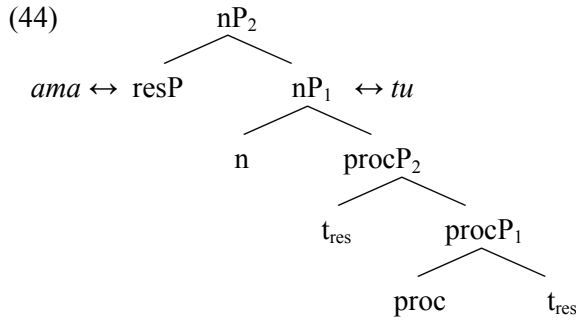

In this way, we get the surface order of morphemes (*ama<sub>res</sub> tu<sub>v+proc</sub>*).

As can be seen, the motivation for having a different sequence of morphemes in syntax and in the surface reduces to the lexical entry of *-tu*, which requires to be paired with the phrasal node *nP* containing *procP*. In order to get such a morphological structure, *resP* has to be extracted, first out of the complement position of *proc*, and then, out of *n*.

Simple deadjectival verbs follow the same pattern. That state is selected by *proc*, and as a consequence, it becomes a *res*. As an example, I show the syntactic/lexical structure of the verb *nagusitu* ‘to grow up’ in a sentence like (45). The LI *nagusi* ‘old, chief’ is lexically associated with state node (=res) which takes Root as complement. Then, *-tu* lexically matches *n* and *proc*. In order for *-tu* match the phrase containing both *n* and *procP*, *res* has been evacuated twice, as suggested previously for the predicate *amatu*.

- (45) Amets      nagusi-tu da  
 Amets.ABS old-TU      be.3sgABS  
 ‘Amets has grown up’ (lit. ‘Amets has become older’)

- (46) *nagusi* ↔ < /nagusi/, state, conceptual content >.

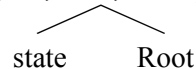

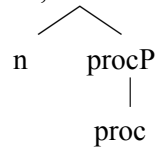
(47)  $-tu \leftrightarrow \langle /tu/, nP \rangle$ 

(48)

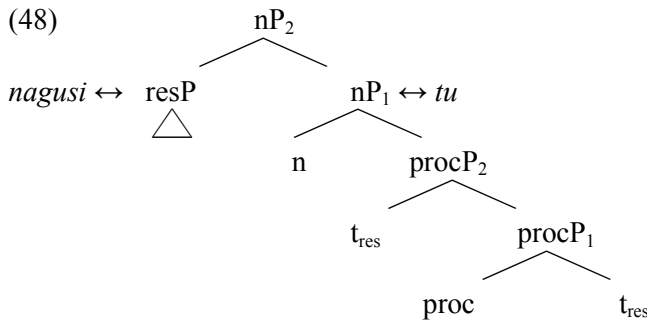

The derivation of complex deadjectival predicates is slightly different. Recall that complex deadjectival predicates are those whose stem consists of more than one element: the Root plus (i) the comparative suffix *-ago*, (ii) the relational adposition *-ko*, (iii) the property suffix *-dun* ‘who has x’, or (iv) its negative counterpart, the suffix *-gabe* ‘devoid, without x’.

Let us consider firstly the stems consisting on the relational *-ko*, the property suffix *-dun* and its antonym *-gabe* ‘without’ (e.g. *etxe-ko-tu* ‘to familiarize’, *zor-dun-du* ‘to become indebted’ and *etxe-gabe-tu* ‘to evict’). I claim that, in these cases, the suffixes/adpositions lexicalize the stateP node only containing the state head. Its Root complement, on the other hand, is lexicalized by the other component: *etxe* ‘house’ in *etxe-ko-tu* ‘to familiarize’ and *etxe-gabe-tu* ‘to evict’ and *zor* in *zor-dun-du* ‘to become indebted’. Here I illustrate the tree previous to each lexicalization for *etxe-ko-tu* and *etxe-gabe-tu*.

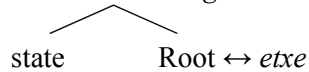
(49)  $stateP \leftrightarrow gabe / ko$ 

In order for *gabe* and *ko* to lexicalize the stateP node only containing the state head, the terminal Root will have to be evacuated to the left of stateP, as argued in previous lines.

Thus, simple and complex deadjectival predicates differ in the number of LIs lexicalizing the state node. In simple deadjectival predicates, a single LI lexicalizes both the subevent and the Root, whereas in complex deadjectival predicates, these heads are lexicalized separately: each one with one LI. This has clear consequences for the categorization of the Root, as I will argue in chapter 4, sec. 4.3.3 and chapter 5, sec. 5.4.

Regarding complex deadjectival predicates consisting of the comparative suffix *-ago* (e.g. *gutxi-ago-tu* ‘to reduce, to decrease’), I suggest that, in this case, *-ago* lexicalizes a Scale node projected above the state subevent.

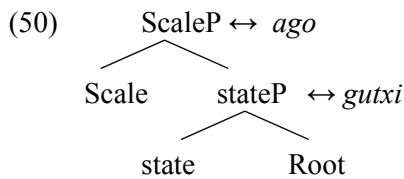

Thus, this kind of complex deadjectival predicates is similar to simple ones, with the only difference that an additional head (Scale) has been projected above. Here, too, the corresponding evacuation movements will have to take place.<sup>28</sup>

Finally, let's turn to deadverbial predicates. Among deadverbial predicates, some are complex, consisting of the scale suffix *-ka* and the Root. These complex deadverbial predicates will be analyzed in section 3.2.1.2. Here, I will focus on simple ones. These are some of the examples obtained using *Corsyntax* (Landa 2008).

<sup>28</sup> The syntactic structure of predicates built on superlatives, like *gutxi-ago-tu* ‘to decrease’, is similar to motion predicates combined with the approximative.

(iii) Maider etxe-rantz joan da  
 Maider.ABS home-approx go-TU be.3sgABS  
 ‘Maider has gone towards home’

According to Pantcheva (2011) approximatives like *etxerantz* ‘towards home’ project a ScaleP which embeds GoalP and PlaceP.

(iv) [Scale [GoalP [Place]

(51) DERIVED FROM ADVERBS<sup>29</sup>

|                                                            |                                                 |
|------------------------------------------------------------|-------------------------------------------------|
| belaunikatu ‘to kneel (down)’                              | belauniko ‘on one’s knees’<br>(belauna ‘kneel’) |
| berandutu ‘to delay, to be late’                           | berandu ‘late’                                  |
| urrundu ‘to move away, to distance oneself from something’ | urrun ‘far’                                     |
| hurbildu ‘to approach sb/sth, to come/bring closer’        | hurbil ‘close, near to’                         |
| gelditu ‘to stop’                                          | geldi ‘still’                                   |
| prestatu ‘to get ready, to prepare’                        | prest ‘ready’                                   |
| adostu ‘to agree, to reach an agreement’                   | ados ‘in agreement’                             |
| zutitu ‘to stand up’                                       | zutik ‘standing’                                |
| zintzilikatu ‘to hang, to suspend’                         | zintzilik ‘hanging’                             |

These predicates can be classified into two groups: (i) those having a change of state/position interpretation (e.g. *gelditu* ‘to stop’, *zutitu* ‘to stand up’ and *berandutu* ‘to become late’)<sup>30</sup>, and (ii) those having a change of location meaning (e.g. *urrundu* ‘to go further / to put something far’, *hurbildu* ‘to go closer / put something closer’). The decomposition of these predicates is similar to that of denominal and simple deadjectival predicates. For instance, a change of state predicate like *zintzilikatu* ‘to hang’ is built on the state predicate *zintzilik* ‘hanging’.

- (52) a. Argazkia zintzilik dago horma-n  
 picture.ABS hanging is wall-INE  
 ‘The picture is hanging on the wall’  
 b. Argazkia zintzilikatu dut  
 picture.ABS hanging-TU have.1sgERG  
 ‘I have hanged the picture’

The state node is lexicalized by *zintzilik* ‘hanging’ (52a). When *-tu* heads the predicate (*zintzilikatu* ‘to hang’) (52b), a *proc* is projected above the state and the relation between *proc* and the state is established as implication. As a consequence, the state becomes a *res*.

<sup>29</sup> Note that many Basque adverbs are also adjectives (*azkar* ‘quick or quickly’, *arin* ‘quick or quickly’, *motel* ‘slow or slowly’) and that the predicates building on this elements have already been listed with deadjectival predicates.

<sup>30</sup> Note that it is not very clear whether *urrundu* and *hurbildu* belong to deadjectival predicates or deadverbial predicates, since *urrun* and *hurbil* can be used as adjectives and as adverbs. This is not actually relevant for the discussion since both deadjectival and deadverbial predicates are assumed to be built on a-categorial Roots.

3.2.1.2. DEADVERBIAL *-KA* PREDICATES

The majority of unaccusative/causative *-ka* derived predicates denote a change of position where the ending location is interpreted as plural.

(53) DERIVED FROM *-KA* ADVERBS

|                                          |                         |
|------------------------------------------|-------------------------|
| mailakatu ‘to rank’                      | maila-ka ‘by levels’    |
| sailkatu ‘to classify’                   | sail-ka ‘by classes’    |
| tartekatu ‘to put at intervals’          | tarte-ka ‘by intervals’ |
| lerrokatu ‘to align, to line up’         | lerro-ka ‘by lines’     |
| zaticatu ‘to chop, to divide’            | zati-ka ‘by pieces’     |
| aldizkatu ‘to alternate, to take turns’  | aldiz-ka ‘by turns’     |
| txandakatu ‘to alternate, to take turns’ | txanda-ka ‘by turns’    |

The predicate *mailakatu* ‘to rank’, which derives from the Root *maila* ‘level’ can be paraphrased as ‘distribute something in levels’. Similarly, *sailkatu* ‘classify’, consisting of *sail* ‘class’ and *ka*, means ‘distribute something into classes’. In this sense, these predicates are similar to change of location predicates, with the difference that, in *-ka* predicates, the aspectual interpretation is durative, since the ending location is multiple. I argue that this difference in meaning is due to the presence of *-ka*, which spells out a central coincidence state subevent and a Classifier head (Borer 2005a).

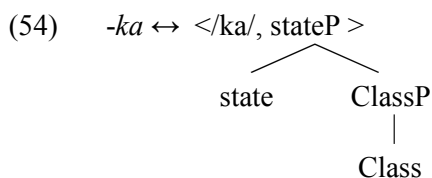

According to Borer (2005a), all NPs are by default mass nouns and it is a functional head Classifier that actually portions out the stuff denoted by the noun. She proposes that, in a language such as English, where classifiers are not traditionally considered to exist, the plural marker *-s* is really a “stuff divider” and is the exponent of the Classifier head.

The object lexicalized as *sail-ka* has at the same time an adverbial and plural meaning. The predicates listed above usually occur with internal plural subjects. The presence *-ka* yields a distributive change of position, where each subject ends up in a different class, level etc.

- (55) *Fitxategiak sail-ka-tu ditut*  
 files.ABS class-KA-TU have.1sgERG.3plABS  
 ‘I have classified the files’

In the case of having a single subject (56), then, a single change of position is triggered, but the ending location is still interpreted as “one x among other x-s”.

- (56) *Fitxategia sail-ka-tu dut*  
 file.ABS class-KA-TU have.1sgERG.3sgABS  
 ‘I have classified the file’

The portioning out meaning is also observed when *-ka* appears attached to an Event naming Root (see chapter 4, sec. 4.3.2)<sup>31</sup>. When it is combined with Roots denoting semelfactive events, it gives rise to iterative or repetitive events:

- (57) *Zu-ri deika ari naiz*  
 You-DAT call-KA PROG be.1sgABS  
 ‘I am calling to you’
- (58) a. *Amets salto-ka etorr-i da*  
 Amets.ABS jump-KA come-TU be.3sgABS  
 ‘Amets has come jumping’
- b. *Jon-ek oihu-ka esan dit [ez zuela etorri nahi]*  
 John-ERG shout-KA say-TU have.3sgERG.3sgABS.1sgDAT [that he didn’t want to come]  
 ‘John has told me shouting that he did not want to come’

The phrase headed by *-ka* (*zuri deika* ‘calling to you’) in (57) has an iterative meaning, as the *-ka* adverbs *salto-ka* ‘jump-ka’ (58a) and *oihu-ka* ‘shout-ka’ (58b).<sup>32</sup>

Consider the sentence (59). The internal subject *fitxategiak* ‘the documents’ originates in the specifier of the state subevent, which after being selected by *proc*

<sup>31</sup> The iterativity is not so clearly seen in other *-ka* deadverbial causative/unaccusative predicates, for example, in *gainezkatu* ‘to overflow’, *erdizkatu* ‘to share half and a half’, *partekatatu* ‘to share a part’ among others.

<sup>32</sup> On the other hand, *-ka* can also combine with a GoalP. Some central varieties of Basque use the allative *-ra* and *-ka* (*ra-ka*) to form the allative approximative, instead of the standard *-ra-ntz*.

- (v) *Etxe-ra-ka noa*  
 house-ALL-KA go  
 ‘I go towards home’

Pantcheva (2011) argues that approximative paths like *-ra-ka* and *-ra-ntz* are syntactically represented by a ScaleP, where the Scale head selects for a GoalP. At the moment, I do not see how *-ka* can be the exponent of both ClassP and ScaleP, but these projections may be basically related, in a way that I am not able to formulate now.

becomes a *res*. The LI *-ka* spells out both the state and the ClassP node, whereas the Root *sail* is the complement of Class.

- (59) *Fitxategiak sailkatu ditut*  
 files.ABS class-KA-TU have.1sgERG.3sgABS  
 ‘I have classified the files’

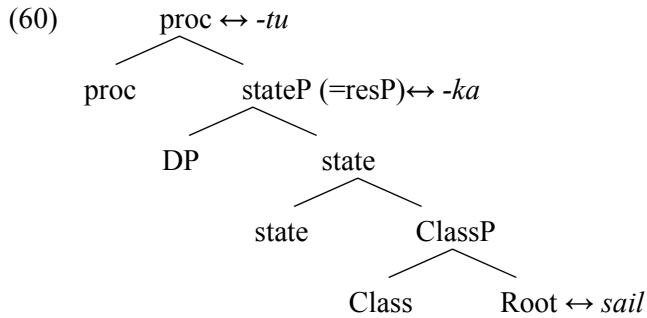

The whole ClassP is the Rheme of the state, and since it can be interpreted as non-atomic, it triggers a durative event, as explained in section 2.3.3.<sup>33</sup>

### 3.2.1.3. DEADPOSITIONAL PREDICATES

Finally, let's consider deadpositional predicates. There are two types of deadpositional predicates in Basque: those built on allative phrases and those built on instrumental phrases. Assuming the classification made in H&K (1993), I suggest that the former group corresponds to location predicates and the latter to locatum predicates. These are some examples:

#### (61) DERIVED FROM THE ALLATIVE PHRASE

|                                          |                                |
|------------------------------------------|--------------------------------|
| etxeratu 'to go/take sb home'            | etxe-ra 'house-ALL'            |
| mahaigaineratu 'to put sth on the table' | mahai-gain-era 'table-top-ALL' |
| kaleratu 'to publish, to dismiss'        | kale-ra 'street-ALL'           |
| aurreratu 'to advance, to move forward'  | aurre-ra 'front-ALL'           |
| giltzapetu 'to shut sb/sth up'           | giltza-pe 'key-under'          |
| munduratu 'to come/bring to the world'   | mundu-ra 'world-ALL'           |
| auziperatu 'to prosecute'                | auzi-pe-ra 'trial-under-ALL'   |
| lehorreratu 'to go ashore, to land'      | lehorr-era 'land-ALL'          |

<sup>33</sup> The structure (60) is a simplified version of the lexicalization. The insertion of *-ka* and *-tu* trigger successive evacuation movements, first of the stateP, and then, of the whole ScaleP.

## (62) DERIVED FROM THE INSTRUMENTAL PHRASE + TA

|                                            |                                    |
|--------------------------------------------|------------------------------------|
| baieztatu ‘to confirm’                     | bai-ez-ta (yes-INSTR-TA)           |
| ondorioztatu ‘to conclude’                 | ondorio-z-ta (conclusion-INSTR-TA) |
| ezeztatu ‘to deny’                         | ez-ez-ta (no- INSTR-TA)            |
| legeztatu ‘to legalize’                    | lege-z-ta (law- INSTR-TA)          |
| argiztatu ‘to illuminate’                  | argi-z-ta (light- INSTR-TA)        |
| balioztatu ‘to validate, to assess’        | balio-z-ta (value- INSTR-TA)       |
| ureztatu ‘to water’                        | ur-ez-ta (water- INSTR-TA)         |
| koloreztatu ‘to color’                     | kolore-z-ta (color- INSTR-TA)      |
| odoleztatu ‘to stain, to cover with blood’ | odol-ez-ta (blood- INSTR-TA)       |
| aireztatu ‘to air, to ventilate’           | aire-z-ta (air- INSTR-TA)          |
| gorriztatu ‘to redden’                     | gorri-z-ta (red- INSTR-TA)         |
| olioztatu ‘to oil’                         | olio-z-ta (oil- INSTR-TA)          |

In this chapter, I will deal only with locatum predicates and leave location predicates for chapter 5, sec.5.2. Locatum predicates, derived from the instrumental adposition, seem to be not as generalized as other types of derived predicates, since some speakers do not recognize them, and their quantity in *Corsintax* (Landa 2008) is much smaller than that of other type of derived predicates.

The element selected by the instrumental is generally a noun (e.g. *lege* ‘law’ in *legeztatu* ‘legalize’ and *argi* ‘light’ in *argiztatu* ‘illuminate’) or an adjective (e.g. *gorri* ‘red’ in *gorriztatu* ‘become red/paint something with red color’). Their meaning indicates that these predicates are locatum: *argiztatu* ‘illuminate’ means ‘provide sth with light’, *legeztatu* ‘legalize’ means ‘provide sth with law’. They differ from denominal and deadjectival verbs like *argitu* ‘to lighten’ in that they have a more complex meaning than a mere change of state (‘become’). As an example, the denominal *urtu* (water-*tu*) means ‘to melt’, ‘to become water’; while the predicate built on the instrumental *ureztatu* (water-*z<sub>INTR</sub>*-*tu*) means ‘to water’, that is to say, ‘to provide sth with water’. Following Hale & Keyser (1993) analysis, I claim that these verbs are locatum predicates, and that they consist of a possessive P (similar to the English ‘with’), which reverses the relation between the Figure and the Ground. In these predicates, it is lexicalized as the instrumental *-(e)z-*.

As can be observed, apart from the instrumental adposition *-(z-)*, an additional LI *-(ta-)* is added between the instrumental and the *-tu* suffix. The morpheme *-ta-* has been traditionally considered an indefinite marker which precedes the locative case endings



(de Rijk 2008: 54). For instance, look at the table below, which shows some varying locative case endings with the noun *etxe* ‘house’.

**Table 3.1.** Locative case endings with *etxe* ‘house’

|          | SINGULAR | PLURAL       | INDEFINITE  |
|----------|----------|--------------|-------------|
| INESSIVE | etxe-an  | etxe-eta-n   | etxe-ta-n   |
| ALLATIVE | etxe-ra  | etxe-eta-ra  | etxe-ta-ra  |
| ABLATIVE | etxe-tik | etxe-eta-tik | etxe-ta-tik |

The *-ta-* morpheme appears preceding the inessive, allative and ablative suffixes in the indefinite paradigm.<sup>34</sup> My suggestion, building on an idea put forward in Etxepare (2013), is that *-ta-* spells out a PLACE feature. It would correspond to the functional instance of a silent PLACE noun, and would appear in contexts where the embedded nominal cannot be considered a “proper” place, but it is nevertheless, embedded in a locative phrase. Note that *-ta-* does not appear in proper names of locations:

**Table 3.2.** Locative case endings with proper names

|          | PROPER LOCATION NAMES |
|----------|-----------------------|
| INESSIVE | Bilbo-n               |
| ALLATIVE | Bilbo-ra              |
| ABLATIVE | Bilbo-tik             |

*-Ta-* does not occur in this context because *Bilbo* is already a place denoting noun. I claim that in the specific context of locatum predicates, *-ta-* lexicalizes the state subevent. Thus, a verb such as *ur-ez-ta-tu* ‘water’ would be paraphrased as ‘reach a state (lexicalized by *-ta-*) of being with water (lexicalized by *ur-ez<sub>INST</sub>*)’ or ‘become with water’. This is the structure previous to lexicalization.

<sup>34</sup> Additionally, in the plural suffixes *-eta-* could perhaps be further decomposed into the pluralizer *-e-* and *-ta-*, in which case, *-ta-* would also be present in the plural paradigm.

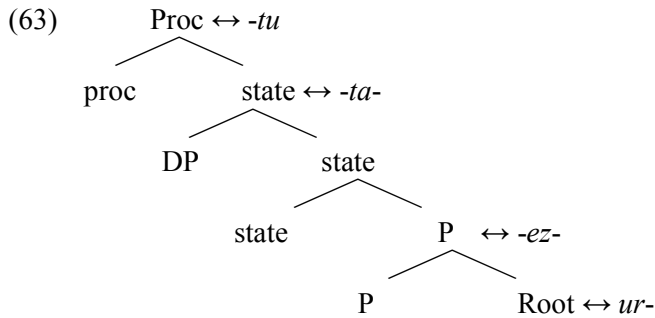

Like in the previous analyses, the insertion of each LI would trigger several evacuation movements, giving rise to the surface sequence of morphemes.

### 3.2.2. Underived predicates

In this section, I examine the decomposition of non-derived unaccusative and causative predicates. The main difference with respect to the derived predicates analyzed previously is that, in non-derived ones, the LI lexicalizing the stem (the predicate without the *-tu* suffix) is additionally specified with *proc* node. Thus, the *-tu* suffix in these predicates is only lexicalizing the  $[_{nP} n]$ . Note that, still, the event structure of derived and non-derived predicates is similar; the only difference lies in the piece of structure matched with each lexical item.

Among non-derived unaccusative and causative predicates, we find predicates of different semantic classes. These are some examples taken from the corpus *Contemporary Reference Prose* (Sarasola et al. 2001), using the *Corsyntax* browser (Landa 2008).

#### (64) INHERENTLY DIRECTED VERBS

*etorri* ‘to come’, *joan* ‘to go’, *heldu/iritsi* ‘to arrive’, *abiatu* ‘to depart’, *igo* ‘to go up’, *jaitsi* ‘to go down’, *sartu* ‘to enter’, *irten* ‘to go out’, *jausi/erori* ‘to fall’, *ekarri* ‘to bring’, *eraman* ‘to carry’, *aldendu* ‘to go further’, *amildu* ‘to tumble’, *agondu* ‘to incorporate’, *eskapatu* ‘to escape’, *ailegatu/arribatu* ‘to arrive’, *arrimatu* ‘to get closer’, *abstraitu* ‘to abstract’, *emigratu* ‘to emigrate’...

## (65) VERBS OF ASSUMING A POSITION OR PUTTING

*etzan* ‘to lie’, *jaiki* ‘to stand up’, *eseri/jesarri/jarri* ‘to sit down’, *altxatu* ‘to stand up’, *kokatu* ‘to settle, place’, *geratu* ‘to stop’, *agondu* ‘to stand up’, *paratu* ‘to place’, *aparkatu* ‘to park’...

## (66) VERBS OF MOTION

*Mugitu* ‘move’, *jaurtiki* ‘throw’

## (67) VERBS OF FINDING, APPEARANCE, DISAPPEARANCE OF OCCURRENCE

*Agertu* ‘appear’, *desagertu* ‘disappear’, *gertatu* ‘occur, happen’, *pasatu* ‘occur, happen’, *suertatu* ‘occur, happen, happen to be’, *topatu* ‘find’, *kausitu* ‘find’

## (68) VERBS OF CHANGE OF STATE

*aldatu* ‘to change’, *antolatu* ‘to organize’, *asaldatu* ‘to disturb’, *aztoratu* ‘to get worried/alarmed/agitated or make sb worried/alarmed/agitated’ *akitu* ‘to get tired or make sb tired’, *atondu* ‘to prepare, arrange’, *amatatu* ‘to switch off’, *aienatu* ‘to frighten away’, *aurkeztu* ‘to present’, *bihurtu* ‘to become’, *bukatu* ‘to finish’, *garatu* ‘develop, advance’, *piztu* ‘to switch on’, *lotu* ‘to tie (up), fasten’, *harrapatu* ‘to catch, grab’, *bilakatu* ‘to transform, convert’, *ezkutatu* ‘to hide’, *moztu* ‘to cut’, *hedatu* ‘to spread, unfold’, *suntsitu* ‘to destroy’, *lehertu* ‘to explode, blow sth up’, *sendatu* ‘to heal, cure’, *kutsatu* ‘to infect, pollute’, *hondatu* ‘to break down, destroy’, *nahastu* ‘to mix’, *urratu* ‘to tear, to rip’

## (69) INSTANTANEOUS VERBS INVOLVING MENTAL PROCESSES

*asmatu* ‘invent’, *onartu* ‘accept’, *barkatu* ‘forgive’, *deliberatu* ‘to decide’, *erabaki* ‘to decide’.

## (70) LOAN VERBS OF CHANGE OF STATE

*Akabatu* ‘kill’, *animatu* ‘cheer up’, *arriskatu* ‘risk’, *alokatu* ‘rent’, *abstenitu* ‘abstain’, *absolbitu* ‘absolve’, *erretiratu* ‘retire’...

## (71) STATIVE/INCHOATIVE VARIABLE VERBS

## a. VERBS INVOLVING PSYCHOLOGICAL PROCESSES OR STATES

*pentsatu* ‘to think’, *ulertu* ‘to understand’, *sinistu* ‘to believe’, *suposatu* ‘to suppose’, *adoratu* ‘to worship’

## b. PERCEPTION VERBS

*ikusi* ‘to see’, *entzun* ‘to hear’, *sentitu* ‘to feel’, *sumatu* ‘to perceive/to suspect’

As claimed above, in non-derived predicates, the LI lexicalizing the stem is additionally specified with the *proc* node. For instance, an LI such as *etor* (the stem of the predicate *etorri* ‘come’) cannot have any other meaning apart from the transitional one. This is due to the fact that the features encoding eventivity and dynamicity are stored in its lexical entry. In contrast, this situation is not observed in the derived predicates analyzed in section 3.1. The stem *etor* is different from the stem of the predicate *amatu* ‘to become a mother’: the LI *ama* ‘mother’ is involved in a transitional interpretation only when accompanied by *-tu*. Thus, the LI *ama* is not specified with a *proc* node, whereas the LI *etor* is lexically associated to this node.

Therefore, the predicates listed above lexicalize a structure consisting of both *procP* and its complement. In the case of the change of location predicate *etorri* ‘to come’ (69), I propose that the LI *etor* lexicalizes both *procP* and *resP*.

- (72) Amets      etorr-i    da  
 Amets.ABS    come-TU    be.sgABS  
 ‘Amets has come’

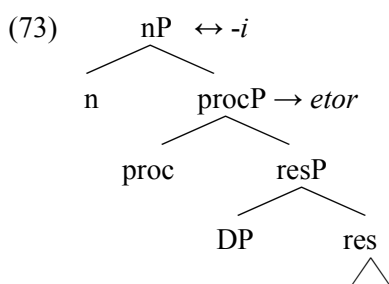

As can be seen, the *-tu* suffix (*-i* in this specific case), spells out just the  $[_{nP} n]$  node. Recall that in the derived predicates analyzed in section 3.2.1, *-tu* lexicalizes both *nP* and *procP*. The Superset Principle allows this kind of situations. For instance, the

Superset Principle says that a LI can match a syntactic node if it contains a superset of the features present in the node (see sec. 2.2.4.2). However, Ramchand (2008b) argues that, with this principle, the lexicalization process is too unconstrained and proposes the following restriction in the context of complex predicates.

- (74) Constraints on Underassociation (Ramchand 2008b: 129)
- a. Underassociation of category features of any ‘main verb’ is in principle possible, constrained by AGREE.
  - b. AGREE-ing categorial features must unify their conceptual content.

Ramchand (2008b) analyzes the relation between the syntactic eventive decomposition and its relation to lexical insertion in Bengali V-V complex predicates and in English denominal verbs. She suggests that a given feature of a verb can be left unused, but only with the condition that this feature is lexicalized by other LI in the process of lexicalization.

Let us explain the case of V-V complex predicates in Bengali. Ramchand shows that, in Bengali, there is a productive construction where a light verb, bearing tense and agreement morphemes, selects for a main verb marked for perfect or conjunctive aspect. The whole construction behaves as monoclausal with respect to agreement, control and anaphora, and has systematically a telic interpretation.

- (75) *gelaš-ta bhem-e gælo*  
 glass-CL break-PERFPART go-PAST3  
 ‘The glass broke’

In this work, she offers an analysis of three light verbs, (i) *jaoya-* ‘go’ (75), (ii) *otha-* ‘rise’ and (iii) *phæla-* ‘drop’, which are, according to her, the most common and productive ones. As full verbs, Ramchand (2008b) considers that these predicates are respectively (i) unaccusative, (ii) ambiguously unaccusative or unergative, and (iii) transitive. She tests the distribution of these predicates with several verbs belonging to different semantic classes and makes the following generalizations: (i) *jaoya-* ‘go’ only combines with unaccusative main verbs; (ii) *otha-* ‘rise’ combines with both unaccusatives and unergatives; and finally (iii) *phæla-* ‘drop’ combines with both transitives and unergatives. This distribution is schematized in the table below (adapted from Ramchand 2008b). I have also included the category labels associated to each predicate type.

**Table 3.3.** Light verb and main verb combination in Bengali

| LIGHT VERB                                               | SELECTED MAIN VERB                                                                                |
|----------------------------------------------------------|---------------------------------------------------------------------------------------------------|
| Unaccusative [ <i>proc, res</i> ]                        | Unaccusative [ <i>proc, res</i> ]                                                                 |
| Unergative [ <i>init<sub>i</sub>, proc<sub>i</sub></i> ] | Unergative [ <i>init<sub>i</sub>, proc<sub>i</sub></i> ]                                          |
| Transitive [ <i>init, proc, res</i> ]                    | Unergative [ <i>init<sub>i</sub>, proc<sub>i</sub></i> ]<br>Transitive [ <i>init, proc, res</i> ] |

Ramchand (2008b) explains this systematic distribution of light verbs and main verbs in terms of the specification of category labels on LIs combined with a constrained theory of lexical insertion. According to Ramchand, light verbs are precisely “light” because some categorial features associated to those LIs are in an Agree relation with another verbal element of its complement. In this analysis, the main verbs lexicalize *res*, according to Ramchand, by means of the perfect ending. The rest of the category features are underspecified and in an Agree relation with the features of the light verb. Thus, this way, it is explained why unaccusative main verbs can only combine with an unaccusative light verb, why unergatives combine both with unergatives and transitives, and why transitives combine only with transitives. Unaccusative verbs are specified with the category labels *proc* and *res*. *Res* is lexicalized via the perfect ending of the main verb and *proc* is underspecified. Since the unaccusative light verb contains also *proc*, the Agree relation is established and their conceptual content is unified. Unergatives can combine with both unergative and transitive light verbs because unergatives contain both *proc* and *init* and these two features are specified in both unergatives and transitive light verbs. They cannot combine with unaccusative light verbs, because unaccusatives do not contain *init* and, in this case, the *init* feature of the unergative main verb would not have a feature to Agree with. Finally, transitive main verbs only combine with transitive light verbs, an outcome which is expected within this analysis of feature Agree.<sup>35</sup>

Ramchand (2008b) applies the same system to English denominal predicates. I will present this view in chapter 3, so that it will not be dealt with here. What matters right

<sup>35</sup> There are two cases which are not expected, though: the incompatibility between unaccusative main verbs and unergative and transitive light verbs cannot be explained within this analysis. However, Ramchand (2008b) posits a further constraint on light verbs:

(vi) The Light Verb Constraint (Ramchand 2008b: 132)

A verb can be used as a light verb when all of its category features Agree with some other verbal element in its complement domain.

now is the Constraints on Underassociation (74), repeated below, which I argue allows the *-tu* suffix to lexicalize only the nP node, excluding procP.

- (76) Constraints on Underassociation (Ramchand 2008b: 129)
- a. Underassociation of category features of any ‘main verb’ is in principle possible, constrained by AGREE.
  - b. AGREE-ing categorial features must unify their conceptual content.

*-Tu* can only spell out nP and leave procP unused, because procP is lexicalized by LI spelling out the stem.

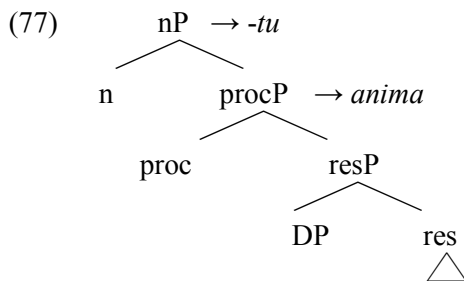

In (77), I show the structure of the predicate *animatu* ‘to cheer up’, without applying the evacuation movements necessary for lexicalization.

### 3.2.3. *-Tu*-less eventive predicates

In previous sections, I have claimed that the *-tu* suffix is specified to spell out the nP node, containing both n and the *proc* node. I have also argued that the node procP may be left underassociated, with the condition that that feature is lexicalized by means of another LI. In this section, I will present a different case: a group of eventive predicates which are not headed by *-tu*.

#### (78) *-TU* LESS EVENTIVE PREDICATES

*bete* ‘to fill’, *hil* ‘to die, to kill’, *pasa* ‘to happen, to cross, to pass’, *igaro* ‘to pass’, *erre* ‘to burn’, *ase* ‘to satisfy’, *kosta* ‘to happen to be difficult, cost’, *gorde* ‘to hide, protect’, *ito* ‘to drown, to suffocate’.

These predicates do not take *-tu* either in the infinitive, citation form (78) (Sarasola in progress) or in the analytic perfect configuration. They remain bare, as can be seen in the examples below.

- (79) Real-ean bi denboraldi txar pasa nituen lesio-engatik  
 [Real-INE two season bad spent have.1sgERG.3plABS.PST injuries-MOT  
 ‘I spent two bad seasons in the Real due to my injuries’  
 [Berria, 2008-01-25]
- (80) Gizona-k ontzi bat bete du... [R. Saizarbitoria, 2008: 554]  
 man-ERG bowl a.ABS filled have.3sgERG  
 ‘The man has filled a bowl’
- (81) [Enpresaburuak gustura geratu dira neurriarekin]; sindikatuak, aldiz, ez  
 [The employers are fine with the measure]; labor unions.ABS, in contrast, no  
 ditu ase  
 have.3sgERG.3plABS satisfied  
 ‘The employers are fine with the measure, but it (the measure) has not satisfied  
 the labor unions’  
 [Berria, 2011-02-12]
- (82) Kosta zaie aitor-tze-a [Berria, 2012-01-06]  
 be-difficult be.3sgABS.3plDAT confess-TZE-DET  
 ‘It has been difficult for them to confess’

Although they do not take *-tu*, these predicates have in the examples above an eventive and a perfect interpretation. *Bete*, *hil*, *erre* and *ase* can also be used in the language as adjectives meaning ‘full’, ‘dead’, ‘burnt’ and ‘satisfied’.<sup>36</sup> *Kosta* ‘to happen to be difficult, cost’ and *pasa* ‘to happen, to cross, to pass’ are Romance loan predicates.

I suggest that this group is like non-derived predicates in that they lexicalize procP without the use of the *-tu* suffix. Nonetheless, they differ from non-derived predicates in that they can also lexicalize the nP node, usually spelled out by *-tu*. As an example, I show the structure of the verb *bete* ‘fill’. As can be seen, *bete* lexicalizes the whole nP, containing procP and resP.

- (83) Amets-ek edalontzia bete du  
 Amets-ERG glass.ABS filled have.3sgERG  
 ‘Amets has filled the glass’

<sup>36</sup> *Ase* ‘satisfied’ can also be used as an adverb.



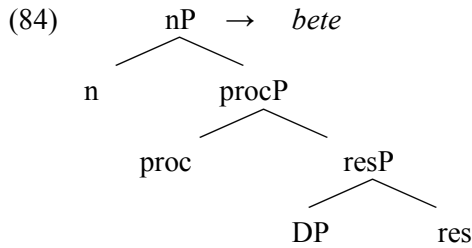

This is because the whole nP is stored in the lexical entry of the LI *bete* ‘to fill’, and this triggers a synthetic realization of the whole structure. This would correspond to the lexical entry of *bete*.

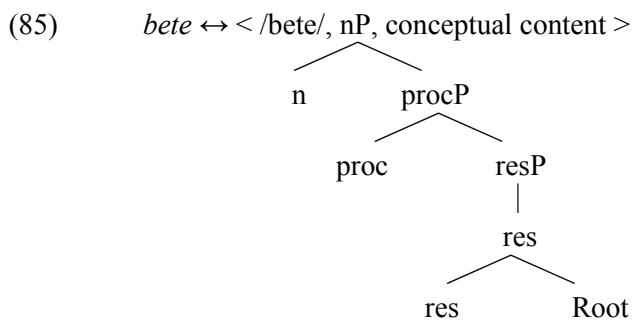

The DP in the specifier of *resP* would need to be cyclically moved to the left of every node until being out of nP.

Someone could argue that, basing on the Superset Principle, nothing would prevent the introduction of *-tu* in the n head, after *bete* has been matched with *procP*, yielding *\*betetu*. Nevertheless, this is not allowed by a blocking mechanism (Kiparsky 2005), an effect that has been termed *Morphological Blocking Principle* in Andrew (1990) and *the Biggest wins* theorem in Starke (2009), Caha (2009) and Taraldsen (2010). This condition accounts for the general observation that a portmanteau morpheme (a single morpheme lexicalizing more than one feature) blocks the introduction of more than one morpheme lexicalizing the same string of features. In Nanosyntax, it is argued that this blocking effect is derived from the fact that lexicalization can happen in phrasal nodes and terminal nodes alike (e.g. Pantcheva 2011), and that it proceeds blindly through the syntactic tree, disregarding whether lower nodes have been matched or not. Thus, when the process of lexicalization reaches the terminal node n, in the structure of (84), *-tu* can be inserted and added to the item lexicalizing *procP* (*bete*), as it is in all predicates. This would result in the ungrammatical *\*betetu*. The

lexical insertion goes on to the phrasal node nP (which contains the whole structure), and two matching lexical items are found: *bete* and *-tu*. *Bete* lexicalizes the whole structure with a single morpheme, while *-tu* needs to evacuate *procP* in order to be introduced in  $[_{nP} \text{ n}]$ . It seems reasonable to assume that the less costly LI will be inserted. In this case, *bete* can lexicalize the whole chunk, without the need of moving any phrase out of nP. Once *bete* is inserted in nP, previously introduced lexical items, like *\*bete-tu*, are ignored.<sup>37</sup>

---

<sup>37</sup> There is a very interesting aspect of *-tu*-less predicates. Even though they do not take *-tu* in all the environments where other predicates take it, *-tu*-less predicates take *-tze* in the imperfective analytic configuration. (e.g. *bete-tze-n* ‘filling’). In chapter 8, section 8.4.5, I will propose that this is due to the fact that *-tze* lexicalizes a bigger structure than *-tu*, and, as a consequence, *-tu*-less eventive predicates need to be combined with *-tze*. They can lexicalize the structure up to the point lexicalized by *-tu*, but no higher.

### 3.3. WHAT ABOUT THE EXTERNAL ARGUMENT?

Most of the predicates that I have analyzed in this chapter can appear in the causative structure consisting of two arguments, but, until now, I have not addressed the introduction of the external argument (EA).

Regarding the elasticity of derived predicates to appear in the causative construction, it seems that almost all denominals and deadjectivals can either be transitive or intransitive. Many deadverbials and location predicates built on the allative adposition, too, can appear with one or two arguments:

- (86) a. Mikel gorri-tu da  
 Michael.ABS red-TU be.3sgABS  
 ‘Michael has blushed’  
 b. Mikel-ek horma gorri-tu du  
 Michael-ERG glass.ABS red-TU have.3sgERG3sgABS  
 ‘Michael has reddened the wall’
- (87) a. Mikel gosetu da  
 Michael.ABS hunger-TU be.3sgABS  
 ‘Michael has gotten hungry’  
 b. Lanak Mikel gosetu zuen  
 work-ERG Michael.ABS hunger-TU have.3sgERG.3sgABS.PST  
 ‘Work made Michael hungry’
- (88) a. Umeak lerro-ka-tu ziren  
 children.ABS line-KA-TU be.3plABS  
 ‘Children put in lines’  
 b. Umeek liburuak lerro-ka-tu zituzten  
 children-ERG books.ABS line-KA-TU have.3plERG.3plABS.PST  
 ‘Children put the books into lines’
- (89) a. Jon [irteteko] presta-tu da  
 John.ABS [to leave] ready-TU be.3sgABS  
 ‘John has got ready to leave’  
 b. Jon-ek jantzia presta-tu zuen  
 John-ERG clothing.ABS ready-TU have.3sgERG.3sgABS.PST  
 ‘John prepared the clothing’
- (90) a. Amets ohe-ra-tu da  
 Amets.ABS bed-all-TU be.3sgABS  
 ‘Amets has gone to bed’  
 b. Aingeru-k Amets oheratu du  
 Aingeru-ERG Amets.ABS bed-ALL-TU have.3sgERG.3sgABS  
 ‘Aingeru has put Amets to bed’

On the other hand, some derived predicates must necessarily have a causative construction. Certain denominals (e.g. *atxilotu* ‘to arrest’), some deadverbials (e.g. *adostu* ‘to agree upon sth’) and, especially, *-ka* derived predicates and locatum predicates need to appear in the causative configuration.

- (91) *Polizia-k Miren atxilo-tu du*  
 police-ERG Mary.ABS prisoner-TU have.3sgERG.3sgABS  
 ‘The police has arrested Mary’
- (92) *Irakaslea-k ikasleak maila-ka-tu ditu*  
 teacher-ERG students.ABS level-KA-TU have.3sgERG.3plABS  
 ‘The teacher has ranked the students’
- (93) *Aingeru-k landareak ur-ez-ta-tu ditu*  
 Aingeru-ERG plants.ABS water-INTR-TA-TU have.3sgERG.3plABS  
 ‘Aingeru has watered the plants’

Like in derived predicates, in non-derived verbs there is quite a lot of variation in their ability to host one or two arguments: some of them can only be unaccusative (94) (*etorri* ‘come’, *jausi/erori* ‘fall’, *desagertu* ‘disappear’, *pasatu* ‘occur, happen’), others only causative (95) (*ekarri* ‘bring’, *eraman* ‘carry’, *topatu* ‘find’, *aparkatu* ‘park’, *akabatu* ‘kill’) and most of them, optionally unaccusative or causative (96) (*igo* ‘go up, rise’, *jaitsi* ‘go down, descend’, *sartu* ‘enter’, *kokatu* ‘settle, place’, *kutsatu* ‘infect, pollute’, *animatu* ‘cheer up’).

- (94) *Hawthorne-ren eskuizkribua desagertu egin zen*  
 Hawthorne-GEN manuscript.ABS disappear-TU do be.3sgABS  
 ‘Hawthorne’s manuscript disappeared’ [O. Arana (P. Auster) 2006: 148]
- (95) a. *Autoa aparka-tu zuen Albertek*  
 car.ABS park-TU have.3sgERG.3plABS.PST Albert-ERG  
 ‘Albert parked the car’ [J. Muñoz (D. Guedj) 2005: 342]
- b. *Azkenean zakurra tiro-z akaba-tu zuten*  
 finally dog.ABS shot-INTR kill-TU have.3plERG.3plABS.PST  
 ‘Finally, they shot the dog dead’ [G. Garate 2002: 58]
- (96) a. *Orduan, Tom sartu zen*  
 then Tom.ABS enter-TU be.3sg.PST  
 ‘Then, Tom entered’ [I. Mendiguren (J.K. Rowling) 200
- b. *Ur epel-etan sartzen ditu bi eskuak*  
 water warm-INE enter-TZE-INE have.3sgERG.3plABS two hands.ABS  
 ‘He/she enters both hands into warm water’  
 [I. Aldasoro (J. Lenihan) 2006: 83]

So far, I have suggested that the syntactic structure of the predicates analyzed is the following.

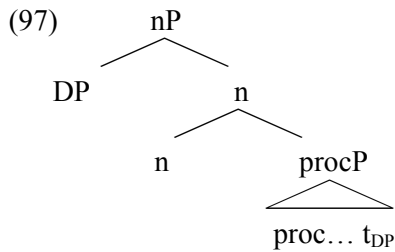

I assume that the internal subject, which originates in the specifier of the result subevent, reaches the specifier position of the nP in order to be accessible for further syntactic operations.

In the following lines, I will briefly consider the introduction of the external subject (see chapter 6 for a detailed analysis of this issue). At the end of the eighties and beginning of the nineties, a number of works (Speas 1986, Kuroda 1988, Koopman & Sportiche 1988 1991) suggested that the subject originates within the VP and that it moves to its surface position, the specifier of inflectional phase, due to case-assignment reasons. This approach is known as the VP-internal hypothesis (Koopman & Sportiche 1991). To this view we owe the idea that the subject (the external argument) does not originate in the specifier of the inflectional phrase, but that it moves from below. Where it is moved from, is a question which has sparked considerable debate.

Kratzer (1996) argues that the EA is not an argument of the verb and that it is related to it by means of secondary predication. A higher functional head, called Voice, is responsible for introducing the EA, as well as assigning accusative case to the internal argument (IA). This head corresponds then to Chomsky's (1995) little *v*. Voice (or little *v*) adds the EA to the verb by means of Event Identification. In this way, Kratzer's hypothesis accounts for Burzio's (1986) generalization that only verbs which have external arguments assign accusative case to their objects.

(98) Burzio's generalization (Burzio 1986)

All and only the verbs that can assign a theta role to the subject can assign accusative case to an object.

Kratzer notes that Voice can come in a non-active version, for which there is no EA insertion and no accusative case assignment. Harley (1995) renames Voice as Event (see also Travis 2000), and argues that primitives like As, Ns or Ps headed by Event are realized as verbs. According to Harley, EventP constitutes the boundary between the s-syntax and the l-syntax, the division made in H&K (1993). Building on this two-way distinction of Voice, Harley (1995) proposes that the Event head can be a CAUSE head or a BE head. The CAUSE head introduces the EA in its specifier. Ramchand's (2008a) view would also go in this line. According to Ramchand (2008a), the *init* head incorporates the INITIATOR in its specifier and has the function of case-assigning the IA.

Since, according to Harley (1995), the Event head is what turns primitives into verbs, we can think that Event is similar to the verbalizing *v* head of Marantz (1997). Nevertheless, in later works (e.g. Pykkänen 2002/2008, Anagnostopoulou 2003, Cuervo 2003, Collins 2005, Coon et al. 2011, Torrego 2012), the verbalizing function and other functions associated to Voice/Event/Little *v* have been segregated and this is the view that I am also going to adopt here. In those approaches, the EA is introduced by Voice and this head selects for a projection headed by the verbalizing head CAUSE or DO. This way, CAUSE and DO are different from the head introducing the external argument (see also Oyharçabal 2003, Harley 2013 and Legate 2014).

In this dissertation, I claim that the EA is projected in a high state subevent which has the function of case-marking the internal argument. In the analytic configuration, this state subevent, that I will call Voice (Kratzer 1996), is not lexicalized by the LIs forming the predicate. Thus, in the event configuration analyzed in this chapter, I claim that it is projected above the nP lexicalized by *-tu*.

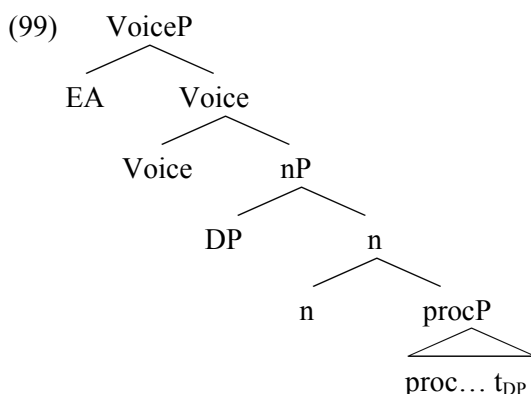

There are reasons to believe that Voice is independent from the lexicalization of *-tu*. For instance, there is a group of stative predicates which do not combine with *-tu*. Interestingly, in this group of predicates, which I call *bare analytic*, EAs can be introduced and IAs can be case-licensed, even though *-tu* is not present.

These predicates only have a stative meaning and their infinitive form consists of (i) an element which can be used independently in the language as a noun, an adjective or an inessive phrase and (ii) an auxiliary verb headed by *-tu*.

(100) a. NOUN HEADED PREDICATES

|                                       |                             |
|---------------------------------------|-----------------------------|
| arrazoi izan ‘to be right’            | arrazoi ‘reason’            |
| ardura izan ‘to matter’               | ardura ‘care, concern’      |
| aitor izan ‘to admit’                 | aitor ‘confession’          |
| aiher izan ‘to wish/hate’             | aiher ‘tendency, hatred’    |
| arta izan ‘to care for’               | arta ‘attention, care’      |
| axola izan ‘to matter’                | axola ‘care, importance’    |
| atsegin izan ‘to like’ <sup>38</sup>  | atsegin ‘pleasure’          |
| amets izan ‘to wish, to long for’     | amets ‘dream’               |
| balio izan ‘to be worth, to cost’     | balio ‘value’               |
| behar izan ‘must, to need’            | behar ‘need’                |
| beldur izan ‘to fear’                 | beldur ‘fear, fright’       |
| damu izan ‘to regret’                 | damu ‘remorse’              |
| falta izan ‘to lack’                  | falta ‘lack’                |
| gorroto izan ‘to hate’                | gorroto ‘hatred’            |
| gura izan ‘want’                      | gura ‘desire’               |
| higuin izan ‘to detest’ <sup>39</sup> | higuin ‘disgust, repulsion’ |
| merezi izan ‘to merit, to deserve’    | merezi ‘merit’              |
| mintzo izan ‘to talk’                 | mintzo ‘speech/language’    |
| nahi izan ‘want’                      | nahi ‘wish, desire’         |
| plazer izan ‘to want’                 | plazer ‘pleasure’           |
| uste izan ‘to think’                  | uste ‘opinion’              |

<sup>38</sup> *Atsegin* can be both a noun or an adjective, meaning ‘pleasure’ or ‘pleasant’. Thus, it can be similarly listed in (28b).

<sup>39</sup> *Higuin* can be either a noun or an adjective, meaning ‘disgust’ or ‘pleasant’. Thus, it can be similarly listed in (100b).

|                                                          |                             |
|----------------------------------------------------------|-----------------------------|
| seinale izan ‘to be noticeable/evident’ <sup>40</sup>    | seinale ‘sign’              |
| zor izan ‘to owe’                                        | zor ‘debt’                  |
| b. ADJECTIVE HEADED PREDICATES                           |                             |
| ageri izan ‘to show, manifest’                           | ageri ‘obvious’             |
| aski izan ‘to be sufficient’                             | aski ‘sufficient’           |
| ezagun izan ‘to be clear/evident, to know’ <sup>21</sup> | ezagun ‘known’              |
| gogoko izan ‘to like’                                    | gogo-ko (desire-GEN)        |
| gustoko izan ‘to like’                                   | gusto-ko (pleasure-GEN)     |
| maite izan ‘to love’                                     | maite ‘dear, beloved’       |
| nahiago izan ‘to prefer’                                 | nahi-ago (wish-comparative) |
| nabari izan ‘to show’                                    | nabari ‘evident, obvious’   |
| c. PREDICATES HEADED BY AN INESSIVE PHRASE OR ADVERBS    |                             |
| begi-tan izan ‘to dislike’                               | begi-tan (eyes-INE)         |
| falta-n izan ‘to lack’                                   | falta-n (lack-INE)          |
| gogo-an izan ‘to remember’                               | gogo-an (mind-INE)          |
| alferrik izan ‘to be in vain’                            | alferrik ‘in vain’          |

De Rijk (2008: 321) calls these predicates *Preterito-present verbs*, because in the analytic configuration they appear bare, without the use of the imperfective suffix *-tzen*, and, still, they trigger an imperfective aspectual interpretation, similar to the English simple present (see also Euskaltzaindia 1997 [1987]: 159).

I prefer to call these type of predicates *bare analytic predicates* to show that they occur without any suffix (*-tu* or *-tzen*).

- (101) a. Justizia eta zuzenbidea maite ditu  
 justice and law.ABS love have.3sgERG.3plABS  
 ‘He/she loves justice and law’ [*Elizen arteko biblia* 2004: Sal 33,5]
- b. Gorroto dut gerra [B.Atxaga 2003: 81]  
 hatred have.3sgERG.3sgABS war.ABS  
 ‘I hate the war’
- c. Asko-k hiltzea nahi-ago zuten [P.Sastre 2003: 228]  
 many-ERG die-TZE-DET wish-COMP have.3sgERG.3plABS.PST  
 ‘Many preferred to die’

<sup>40</sup> Thanks to Mari Jose Ezeizabarrena for making me aware of these bare analytic predicates used in her dialect (even though she does not accept the meaning ‘to know’ for *ezagun izan*. That meaning has been noted from Elhuyar).



These predicates are always used in the analytic form and not in the synthetic one. Remarkably, as noted by de Rijk (2008), they depart from canonical analytic forms in that they are not headed by *-tu* or *-tzen*, traditionally considered [+bound] and [-bound] aspect morphemes (see chapter 7).

As I have mentioned, these predicates are stative, so that they spell out a structure without *proc*. I claim that the nouns, adjectives and PPs listed in (100) lexicalize a state subevent, where the internal argument occupies the specifier position.<sup>41</sup> In a predicate like *balio izan* ‘to be useful/worth’, the LI *balio* ‘value’ –which is independently used as a noun– spells out the stateP node.

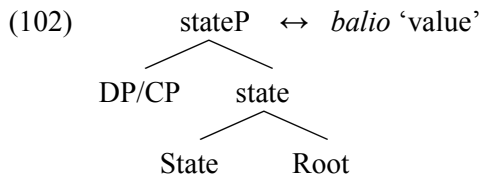

In the predicate *gogoan izan* ‘to remember, to have in mind’, on the other hand, the inessive adposition spells out the [<sub>stateP</sub> state] node, and the Root (which surfaces as a nominal) is independently lexicalized by *gogo* ‘mind’.

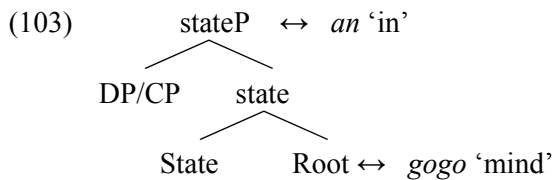

A similar analysis has been proposed in Etxepare & Uribe-Etxebarria (2012) for the modal *behar* ‘must’, a predicate which is listed in (100). As can be seen in the examples, the modal *behar* ‘must’ can take a DP complement (104) or an infinitive complement (105).

(104) Jon-ek kamiseta urdina behar du  
 John-ERG t-shirt blue.ABS need have.3sgERG.3sgABS  
 ‘John needs the blue t-shirt’

(105) Jonek kamiseta urdina aukera-tu behar du  
 John-ERG t-shirt blue.ABS chose-TU need have.3sgERG  
 ‘John must chose the blue t-shirt’

<sup>41</sup> See however chapter 7, sec. 7.5.1 for some exceptions.

Etxepare & Uribe-Etxebarria (2012) argue that *behar* is really a nominal predicate (meaning ‘need’) which heads a small clause, whose subject is the DP (101) or the non-finite predicate (102). In their analysis, the external argument (EA) is related to the small clause headed by *behar* externally, introduced by an Applicative head.

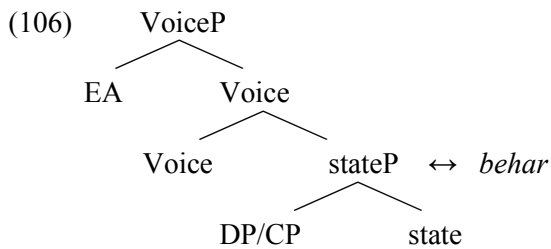

Following Etxepare & Uribe-Etxebarria (2012) in spirit but not in the details, I claim that the EA is introduced by a Voice head, projected above the stative subevent.<sup>42</sup>

Now, what is interesting about bare analytic predicates is that, even though they do not combine with *-tu* in the analytic configuration, they appear with internal arguments (IAs) –DPs or CPs– and external arguments (EAs), which are all cross-referenced in the auxiliary by their corresponding agreement morphemes. I repeat here the examples in (101)

- (107) a. Justizia eta zuzenbidea maite ditu  
 justice and law.ABS love have.3sgERG.3plABS  
 ‘He/she loves justice and law’ [Elizen arteko biblia 2004: Sal 33,5]
- b. Gorroto dut gerra [B.Atxaga 2003: 81]  
 hatred have.3sgERG.3sgABS war.ABS  
 ‘I hate the war’
- c. Asko-k hiltzea nahi-ago zuten [P.Sastre 2003: 228]  
 many-ERG die-TZE-DET wish-COMP have.3sgERG.3plABS.PST  
 ‘Many preferred to die’

As mentioned before, this yields the following conclusion: the function of introducing the EA and case-marking the IA must not be attributed to the nominalizing node spelled out by *-tu*.

As I have shown in this chapter, the suffix *-tu* has the ability to turn its complement into a predicate. Thus, *-tu* could be considered, if it were not for its nominal category

<sup>42</sup> See chapter 7, sec. 7.3 for more details on the interpretation of the external argument introduced by Voice.

(see chapter 5, section 5.3), a verbalizer in the sense of Marantz (1997). Recall that in some works like in Harley (1995), the verbalizing function is performed by the same head which introduces the external argument. In Basque, this cannot be true, since, as I have shown, the presence of *-tu* is independent from the introduction of the EA and case-licensing the IA, two functions usually attributed to Voice.

In this sense, and following up the previous discussion, several studies have suggested that the head introducing the EA and case marking the IA is different from the verbalizing head (Pylkkänen 2002/2008, Anagnostopoulou 2003, Cuervo 2003, Collins 2005, Coon et al. 2011, Torrego 2012). Although I do not believe that a verbalizer head actually exists in Basque (see chapter 4), what is clear is that *-tu* must be disassociated from Voice.

### 3.4. CONCLUSIONS

In this chapter, I have analyzed the syntactic decomposition and lexicalization of unaccusative and causative (derived) predicates in Basque. I have claimed that, in derived predicates, the stem lexicalizes the structure below *proc* –a resP or, in some cases, a ScaleP– and that *-tu* spells out procP and nP. Thus, a LI like *lehor* ‘dry’ lexicalizes the phrase [<sub>stateP</sub> state Root], which after *-tu* is merged and *proc* is projected, becomes a resP. This lexicalization pattern, where LIs can lexicalize whole phrases, is allowed under the *Phrasal Spell Out* principle (Fábregas 2007, Starke 2009, Caha 2010, Pantcheva 2011), assumed in the Nanosyntax framework and introduced in chapter 2.

On the other hand, I have also dealt with non-derived predicates, which also combine with *-tu*, and with other *-tu*-less non-derived predicates. Regarding the former group, I have argued that *-tu* only lexicalizes [<sub>nP</sub> n], and the whole procP is spelled out by the LI spelling out the stem (e.g. *etor* in *etorri* ‘to come’). In *-tu*-less predicates, in contrast, the whole [<sub>nP</sub> n proc resP] is spelled out by a single LI (e.g. *bete* ‘to fill’).

Finally, I have briefly addressed the introduction of the external argument and I have claimed that, in Basque, the EA is introduced outside the nP lexicalized by *-tu*, by a state head (labeled Voice) which has the function of case-assigning the internal argument. That *-tu* and Voice must be distinguished in Basque has been supported by the fact that bare analytic predicates, which do not combine with *-tu* in the analytic configuration, can have external arguments and internal arguments like any other predicate headed by *-tu*.



#### **4. Unergative & non-causative transitive (derived) predicates**



#### 4.1. INTRODUCTION

In this chapter, unergative and non-causative transitive predicates will be considered. I call the transitive variant non-causative, because the direct object of these constructions does not undergo a change of state or position, like those analyzed in chapter 2.<sup>43</sup> I claim that these predicates consist of the process subevent, and do not project a result. These are some examples:

- |     |                                  |               |
|-----|----------------------------------|---------------|
| (1) | dantzatu ‘to dance’              | [proc, Rheme] |
|     | hitz egin ‘to speak, to talk’    | [proc, Rheme] |
|     | aztertu ‘to examine, to analyze’ | [proc, Rheme] |

The predicates analyzed in this chapter take a Rheme complement directly, instead of a state subevent. In chapter 2, I claimed that the Rheme of a state is the Ground of the central coincidence relation introduced by the state subevent, and that when a multiple valued measure (a PATH) is mapped to the state, it yields multiple central coincidence relations. The homomorphism between *proc* and its Rheme is slightly different, since *proc* does not introduce a central coincidence relation, but a time span. When the Rhemes are mapped to the process subevent, the structure of the measure denoted by the Rheme is mapped onto the temporal structure of the process subevent.

- (2)  $\text{RHEME OF PROCESS}(p, e) =_{def} \forall e \forall t \forall p [proc(e) \cap R(e, p) \cap t' \subseteq \tau(e) \rightarrow \exists i [i \subseteq p \cap R(t', i)](mapping\ to\ measures) \cap \forall e \forall p \forall i [proc(e) \cap Re, p \cap i \subseteq p \rightarrow \exists t' t' \subseteq \tau(e) \cap R t', i (mapping\ to\ events)]$

The formulation in (2) indicates that for all subevents *e*, subintervals *t'* and measures *p*, iff *e* is a process subevent, has *p* (Rheme) as its measure and *t'* is a subinterval of the running time of *e* ( $\tau(e)$ ), there is a point *i* belonging to *p* which is mapped to the subinterval *t'*. The reverse also holds: for all subevents *e*, measures *p* and points *i*, iff *e* is a process subevent, *p* is the measure of *e* and *i* is a point in *p*, there is a subinterval *t'* which is part of the running time of *e* and which is mapped to the point *i*.

To sum up, (2) means that all points *p(i)* of the measure of a process subevent involve a subinterval *t'* of the running time of the process subevent, and vice versa. This guarantees that the (spatial) structure of the Rheme is mapped to the temporal structure of the event.

<sup>43</sup> The transitive predicates that I am analyzing in this chapter are actually what Levin (1999) calls *Non Core Transitive Verbs*. Note however, that in this chapter, I will only analyze eventive predicates.



As I have said, the predicates that will be analyzed in this chapter involve Rhemes of process, as depicted in (2). These predicates differ from those analyzed in chapter 1 regarding case assignment and auxiliary selection. In the intransitive variant of the predicates, the only argument is marked ergative case and the auxiliary selected is \**edun* ‘have’.

- (3) a. Anek dantza-tu du  
       Ane-ERG dance-TU have.3sgERG  
       ‘Ane has danced’  
    b. Mirenek eskia-tu du  
       Miren-ERG ski-TU have.3sgERG  
       ‘Miren has skied’

This is because ergative marking and auxiliary selection in Basque is sensitive to the unaccusative-unergative distinction (see Perlmutter 1978, Perlmutter and Postal 1982, Burzio 1986, for the distinction; Levin 1983, Etxepare 2003, Berro 2010 2012, for Basque).

#### 4.1.1. On unergative predicates

Basque unergative predicates have been extensively analyzed in the literature (among others, Uribe-Etxebarria 1989, Laka 1993a, Fernández 1997, Etxepare 2003, Aldai 2006 2009, Berro 2010, Creissels & Mounole 2012). The fair amount of attention payed to unergatives is due, to a large extent, to their significance and implications for the case-system of the language. Recall that Basque is an ergative language: subjects are marked differently depending on whether they are the subject of a transitive clause or of an intransitive clause (Dixon 1994). Intransitive clauses, however, do not show a uniform pattern in Basque; the subjects of unaccusative predicates (like those analyzed in chapter 3) are marked absolutive, whereas the subjects of unergative predicates are generally marked ergative,<sup>44</sup> like the subjects of transitive clauses.

- (4) a. Ane etorr-i da  
       Ane.ABS come-TU be.3sgABS  
       ‘Ane has come’  
    b. Ane-k dantza-tu du  
       Ane-ERG dance-TU have.3sgERG  
       ‘Ane has danced’

---

<sup>44</sup> Note that some unergatives take absolutive subjects in north-eastern varieties.

- c. Ane-k tangoa dantza-tu du  
 Ane-ERG tango.ABS dance-TU have.3sgERG.3sgABS  
 ‘Ane has danced a tango’

Levin (1983: 290-ff) was the first linguist to point out that there is a semantic split conditioning the case-marking of intransitive predicates in western and central Basque. She proposed that the ERG/ABS split in Basque intransitives was based on the agentive/non-agentive status of the subject (Levin 1983: 298). For instance, agentivity has been considered a determining factor for the division of unergative and unaccusative predicates (Perlmutter 1978).

In this dissertation, I argue that the case-assignment and auxiliary selection contrast found between unergative and unaccusative predicates is due to the first-merge position of the subject. As I suggested in chapter 3, the subject of an unaccusative predicate like *jausi* ‘to fall’ or *gorritu* ‘to redden’ originates in the specifier of a state subevent. States are relational elements (in the sense of Mateu 2002) and need to have a subject in their specifier (an inner subject in terms of Hale & Keyser 1993). This state is lexically associated with the LIs *jausi* and *gorritu*. The subject of an unergative predicate, in contrast, is not originated in a state associated with the LI itself, since the LIs associated with unergative predicates do not spell out states. The subject of an unergative predicate is thus introduced outside predicates, by a stative head that I have labeled Voice (following Kratzer 1996 and many others).

In this section, I will analyze the syntactic/eventive decomposition of the unergative and non-causative transitive predicates and, additionally, their lexicalization process, as done in chapter 3.

There are two types of unergative predicates: morphologically simple and complex. The simple ones consist of a stem and the suffix *-tu* (see e.g. *dantzatu* ‘to dance’ in (4b)) and are the only type of predicates used also in transitive variants, that is to say, with an overt DP direct object (4c). Complex unergatives, in contrast, consists of the light predicate *egin* ‘do’ and, usually, a bare noun, and cannot take a further DP direct object (5).

- (5) a. Ane-k dantza egi-n du  
 Ane-ERG dance do-TU have.3sgERG  
 ‘Ane has danced’  
 b. \*Ane-k tangoa dantza egi-n du  
 Ane-ERG tango.ABS dance do-TU have.3sgERG  
 ‘Intended: Ane has danced a tango’

As observed by Sarasola (1977), Uribe-Etxebarria (1989), Laka (1993a), H&K (1993), Etxepare (2003), Oyharçabal (2006), Aldai (2009), most unergative predicates in Basque are complex, built on the basis of the light verb *egin* ‘do’ and a bare noun.

As I have mentioned in chapter 2, Hale & Keyser (H&K onwards) propose that unergative predicates are underlyingly transitive. In their 1993 work, they suggest that the object noun is incorporated onto V at I-syntax. Then, in later works (H&K 2002 2005), they claim that the LI of these predicates is base generated in V-position, but that they license non-overt nominal objects. In both approaches, unergative predicates are considered transitive in nature.

The transitive syntax of unergative verbs posited in H&K (1993) was actually reinforced by the fact that in Basque, there are morphologically complex unergative predicates (Laka 1993a), which, as I have shown, consist of two overt elements: a light predicate *egin* meaning ‘do’ and a second object, usually of nominal category.

- (6) a. Ane-k dantza egi-n du  
 Ane-ERG dance do-TU have.3sgERG  
 ‘Ane has danced’  
 b. Ane-k dantza-tu du  
 Ane-ERG dance-TU have.3sgERG  
 ‘Ane has danced’

The morphological contrast of the predicates in (6) would reflect the absence vs. presence of incorporation of the nominal object onto V. For instance, some analyses (Uribe-Etxebarria 1989, Bobaljik 1993, Laka 1993a and Fernández 1997) have suggested that the complement of the light verb *egin* represents actually a non-incorporated object, which may incorporate after spell out (Fernández 1997). As Uribe-Etxebarria (1989) pointed out (see also Oyharçabal 2006), *egin* and its complement can appear separated in some contexts (in interrogative sentences and in focalized structures) and the complement may be marked partitive in negative sentences, as common direct objects.

- (7) a. Nork egin behar du lan?  
 who.ERG do need have.3sgERG work  
 ‘Who has to work?’  
 b. Nork egin du lan?  
 who.ERG do-TU have.3sgERG work  
 ‘Who has worked?’  
 (8) Oso ondo egin duzu lan  
 very well do-TU have.2sgERG work  
 ‘Very well you have worked’

- (9) Ez dut            lan-ik        egi-n  
 no have.1sgERG work-PART do-TU  
 ‘I haven’t worked’

Furthermore, the bare nominal may also be quantified, like common direct objects, and *egin* can be silenced in sentences with negative contrastive focus (Oyharçabal 2006: 792-793):

- (10) a. Lo gutxi egi-n dut  
 sleep little do-TU have.1sgERG  
 ‘I have slept a little’  
 b. Lan gehiegi egi-n dut  
 work too-much do-TU have.1sgERG  
 ‘I have worked to much’
- (11) a. Lan egi-n dut,            ez lo  
 work do-TU have.1sgERG, no sleep  
 ‘I have worked, not slept’  
 b. Irri egi-n dut,            ez oihu  
 laugh do-TU have.1sgERG, no shout  
 ‘I have laughed, not shouted’

Note however, that the bare noun of complex unergative predicates does not behave as a common direct object in other aspects: e.g. its lack of determiner and its position with respect to manner adverbials. See Oyharçabal (2006) for a discussion on the (non)-incorporation of the noun, and the variation in dialects and predicates.

In relation to the case-system, the transitive hypothesis of unergatives implies the idea that ergative case in ergative systems such as Basque is second-to-absolutive (e.g. Ortiz de Urbina 1989, Bobaljik 1993, Laka 1993a, Bittner and Hale 1996, Fernández 1997): this way, the non-incorporated object gets absolutive case, and, then, the subject is assigned ergative case.

Regarding simple unergative verbs, Bobaljik (1993), Laka (1993a) and Fernández (1997) have also considered they are truly transitive. On the one hand, Bobaljik (1993) and Laka (1993a) suggest that this kind of predicate takes a non-overt complement. On the other hand, Fernández (1997) proposes that the object (e.g. *dantza* in (9b)) is incorporated in the computational system, after I-syntax but before spell-out. In both cases, the internal argument of the predicate would be assigned absolutive case from V, and the subject would then be assigned ergative case by the functional T. The transitive hypothesis of simple unergative predicates is additionally supported by the

selection of the auxiliary (*du* ‘has’), which would seem to require an underlying object.<sup>45</sup>

The transitive hypothesis of unergative predicates has a problem: as pointed out in Laka (2006b) and Preminger (2012), not all unergative predicates can be decomposed into a nominal and *-tu*, or into a nominal and *egin*. As I will show in section 4.2.2, some loan verbs like *eskiatu* ‘to ski’ or *eskalatu* ‘to climb’ are not transparently built on nominals like \**eskia*<sub>N</sub> or \**eskala*<sub>N</sub>. Nevertheless, they behave like other unergative predicates, taking an ergative marked subject.

My position is that predicates like *dantzatu* ‘to dance’, as well as *eskalatu* ‘to climb’ are decomposed into a structure where the process subevent takes a PATH as complement. In a transitive configuration, the PATH complement is overtly expressed by a separate LI: *tangoa* in (12a) and *Urdulizeko horma batzuk* in (12b).

- (12) a. Ane-k tangoa dantza-tu du  
 Ane-ERG tango.ABS dance-TU have.3sgERG.3sgABS  
 ‘Ane has danced a tango’  
 b. Ane-k Urdulizeko horma batzuk eskala-tu ditu  
 Ane-ERG Urduliz-gen wall some.ABS climb-TU have.3sgERG.3plABS  
 ‘Ane has climbed some walls from Urduliz’

In the intransitive variant (13), in contrast, I suggest that both the process and the PATH are lexicalized by the predicate. The Root is the PATH object.

- (13) a. Ane-k dantza-tu du  
 Ane-ERG dance-TU have.3sgERG  
 ‘Ane has danced’  
 b. Ane-k oso ondo eskala-tze-n du  
 Ane-ERG very well climb-TZE-INE have.3sgERG  
 ‘Ane climbs very well’

Preminger (2012) argues against the hypothesis that there is an implicit object in simple unergative predicates, but, nevertheless, he accepts that “one could imagine that what the language lacks is not exactly the nominal lexical entries for *eskia* (‘ski’) or *disdira* (‘shine’), but rather the ability to pronounce these roots as nominals” (2012: 5). In the latter case, he suggests that if they are phonologically null or incorporated, there would not be any obstacle to their pronunciation. Pineda (2014: 378-379) also defends this view: she suggests that within a neoconstructionist view of argument

<sup>45</sup> Note, however, that many works have suggested that the selection of the \**edun* ‘have’ auxiliary root is not determined by transitivity (e.g. Albizu 2001, Arregi 2004, Preminger 2012, Arregi & Nevins 2012). For instance, markers like *d-*, *z-* etc. are not considered 3<sup>rd</sup> person absolutive agreement markers in Laka 1993b (vs Ortiz de Urbina 1989, Hualde 2003b). According to this view, then, the selection of auxiliary *du* ‘has’ cannot be considered to be a piece of evidence in favor of the transitive hypothesis.

structure –the approach adopted within the Distributed Morphology (and also in Nanosyntax)–, nothing prevents an abstract morpheme like *eski* to be the complement of the verb, even though that Root is only realized in verbal environments, and not in nominal ones. In this dissertation, I will take this position, and argue that in unergative predicates, the *proc* head selects for a Root. This Root may surface as a nominal in some contexts, like *dantza* in *dantza egin*, but not necessarily, e.g. *eskia* in *eskiatu* ‘to ski’. Regarding the case-requirements of Roots, building on the idea put forward in Coon (2010) that bare Roots surface as nominals, I suggest the following generalization:

(14) Generalization on Roots

Roots surface as nominals and need to be case-licensed if they are lexicalized separately from their respective subevent.

Thus, a given Root which is lexicalized by an LI not lexicalizing also its respective subevent will be realized as a nominal and will have to be case-licensed some way or another. This generalization will be particularly enlightening for the analysis of complex unergatives (see section 4.3).

#### 4.1.2. On Rhemes

As I showed in chapter 1, Rhemes can be entity denoting DPs (15ab), Roots denoting gradable properties (15cd) and DPs/PPs denoting spatial paths (15ef). In the case of Property naming Roots, I claimed that they are the complements of a state subevent, which after being selected by *proc*, become a *res*. I argued that depending on the properties of the measure associated to them, the resulting change of state is interpreted as durative or as instantaneous.

- (15) a. John ate an apple  
 b. John collected the stamps from the floor  
 c. The water cooled down  
 d. John flattened up  
 e. John walked three miles  
 f. John pushed the cart to the window

(Fabregas & Marin 2012: 12)

Entity denoting DPs (15ab) and DPs/PPs denoting spatial paths (15ef) are the Rhemes of process and they occupy the complement position of *proc*. As I explained before, the structure of the measures associated to them is homomorphically related to

the temporal structure of *proc*. Most of the times, Rhemes of *proc* are elements which denote monotonic and incremental or transitional sets of measures (PATHS). When *proc* selects for this type of element, the resulting event is dynamic.

In chapter 2, I have proposed that gradable Property naming Roots denote a set of points ordered along a dimension, e.g. a scale of coolness in the case of the Root *cool* (15c). In this chapter, I will claim that Event naming Roots like *kanta* ‘song’ and Thing naming Roots like *elurra* ‘snow’ are also associated to measures and that, in intransitive predicates like the following, the structure of these measures is mapped to the temporal progress of the process event:

- (16) Jon-ek kanta-tu du  
 John-ERG song-TU have.3sgERG  
 ‘John has sung’
- (17) Elurra egin du  
 snow do-TU have.3sgERG  
 ‘It has snowed’

Event naming Roots (e.g. *kanta* ‘song’) and Thing naming Roots (e.g. *elurra* ‘snow’) are Rhemes of process. In the case of Event naming Roots like *kanta*, the measure associated to the Rheme is scalar. As a consequence, a Root of this type can be considered a PATH object. The Root *kanta* is associated to a scale (p) which consists of ordered points denoting the progression of the song.

- (18) *kanta*(p)  
 — + + + + + → ∞  
 0 1

- (19)  $\llbracket kanta \rrbracket = \{VAL(p(i_n)) = VAL(p(i_{n-1})) + d\}$

The numerical value of each point in the scale of the song(p) is equal to the value of the anterior point plus an indefinite difference value. Therefore, the measure denoted by *kanta* is incremental, in the sense that the song gets bigger from point to point. It develops incrementally through bigger and bigger stages (see Landman & Rothstein 2012b).

As can be observed, the scale denoted by Roots like *kanta* is similar to that of *wide* and approximative paths like *towards home*, analyzed in chapter 2, sec.2.3.2: it does not have an upper bound, but does have a lower bound, which corresponds to the time that it needs to be established (Dowty 1979, the *onset* in Landman & Rothstein 2012b).

The event develops along the progress of the song. Earlier intervals in the running time of the event ( $\tau(e)$ ) match points of  $\text{song}(p)$  which involve smaller parts of the song and later intervals match points corresponding to bigger parts.

$$(20) \quad \begin{array}{cccccc} \tau(e): & t'_1 & t'_2 & t'_3 & t'_4 & t'_5 & t'_6 \\ & - & + & + & + & + & + \\ & & & & & & \rightarrow \infty \\ p(e): & i_1 & i_2 & i_3 & i_4 & i_5 & i_6 \end{array}$$

This way, scalar measures like that of *kanta* give rise to dynamic predicates.

There are different types of Roots: Property naming Roots, already mentioned in chapter 3, Event naming Roots and Thing naming Roots (see Harley 2005). The measures associated to these types of Roots have different properties depending on whether they are [ $\pm$ incremental], [ $\pm$ transitional], [ $\pm$ lower bound] and [ $\pm$ upper bound]. These properties are not restricted to the measures arising from Roots, since, as I will show, the measures of quantized DPs and *-ka* derived stems can also be defined in these terms. The positive or negative value of these properties will determine the final aspectual shape of the predicate.

Interestingly, I will also show that *proc* can merge with Rhemes associated to monovalued measures (non-dynamic Rhemes). Recall that in change of state predicates (analyzed in chapter 3), the *res* subevent can take this kind of Rheme, in which case, the transition to the result state is interpreted as instantaneous. If the *proc* subevent takes as complement a non-dynamic Rheme, the resulting predicate is interpreted as static and eventive (termed *d-states*, following Maienborn 2005, Rothmayr 2009 and Fábregas & Marín to appear, see chapter 5).

Non dynamic Rhemes are defined by virtue of being associated to [ $-$ incremental] and [ $-$ transitional] measures. On the one hand, they are not incremental in the sense that all the points of  $p$  correspond to the same numerical value.<sup>46</sup> This fact implies that the measure arising from this kind of Rheme is not monotonic on the object denoted by the Rheme. On the other hand, these measures do not involve a transition to a different phase (i.e. from a negative to a positive phase or from a positive to a negative phase). In (22), I show the definition of the measure associated to the Event naming Root *shine*.

<sup>46</sup> Note that *shine* can also be related to a gradable measure in terms of amounts of shining. For instance, in Basque, the adjective *distiratsua* 'shining' can be modified by *oso* 'very' and be headed by the comparative suffix *-ago* (*distiratsuagoa* 'more shining'). However, I claim that this measure is not involved in the mapping to the temporal structure of *proc*, since the event *shine* does not develop along bigger and bigger amounts of shining.



$$(21) \quad \begin{array}{cccccccc} + & + & + & + & + & + & + & + \\ & & & & & & & 1 \\ & & & & & & & \\ p(e): & i_1 & i_2 & i_3 & i_4 & i_5 & i_6 & i_7 \end{array}$$

$$(22) \quad \llbracket \text{shine}(p) \rrbracket = \left\{ \begin{array}{l} \text{VAL}(p(i_n)) = \text{VAL}(p(i_{n-1})) = \text{VAL}(p(i_{n+1})) \\ \text{Iff } p(i_n) \text{ is positive, then } p(i_{n-1}) \text{ and } p(i_{n+1}) \text{ are also positive.} \end{array} \right\}$$

Since all the points of the measure associated to *shine* are the same, monotonicity is a relevant property neither in the measure nor in the mapping to the temporal structure. When the different subintervals of  $\tau(e)$  match the points of  $p$ , an interpretation emerges where the time goes on without any progression of the event, giving rise to a static reading. Thus, *proc* may be present in non-dynamic predicates as well, a fact that has already been pointed out by Fábregas & Marín (2012). This different characterization of process and its aspectual consequences will be also analyzed in chapter 4, when we deal with stative predicates.

#### 4.1.3. Outline

The outline of this chapter is the following: firstly, I will address morphologically simple predicates. I will analyze their syntactic/eventive decomposition and lexicalization, first, in derived predicates (4.2.1), and second, in underived predicates (4.2.2), also explaining the introduction of direct objects which cannot be considered to be homomorphic with the process denoted by the predicate (4.2.3). In the third section, I will focus on complex unergative predicates. I will show that depending on the type of Root, the aspectual class of the entire predicate can be derived (4.3.1). Then, I will concentrate on certain constraints of complex unergative verbs, such as the complementless restriction (4.3.2), the impossibility to have an internal subject (4.3.4) and the necessity of the external argument (4.3.5). I will suggest that, in the end, all these constraints can be explained with the Generalization on Roots, which states that the Roots which are lexicalized separately from a subeventive node surface as nominals and have to be case-licensed. In section 4.4, I will deal with certain aspectual contrasts between simple and complex verbs, reported by Etxepare (2003), and which also involve absolutive and dative case variation of the object. I will show that complex unergatives resist telicization by an allative modifier because in complex unergatives the Root is occupying the position of complement of *proc*, and that is

precisely the position which the telicizing allative modifier occupies in the simple variant. Finally, in section 4.5, the main conclusions of the chapter will be presented.

## 4.2. MORPHOLOGICALLY SIMPLE PREDICATES

### 4.2.1. Derived predicates

Two groups can be distinguished in derived unergative and non-causative transitive predicates: (i) denominals, whose stem is used outside the predicate as a nominal (e.g. *dantza* 'dance' in *dantzatu* 'dance', *agur* 'greeting' in *agurtu* 'greet'); and (ii) deadverbials, built on a stem consisting of *-ka*. Both groups (denominal and *-ka* derived predicates) were also mentioned in chapter 3 (for predicates like e.g. *ama-tu* 'to become a mother' and *maila-ka-tu* 'to rank'). Nevertheless, in contrast to the predicates analyzed in chapter 3, the stems on which unergative and non-causative transitive predicates are built lexicalize the process subevent, rather than a state subevent.<sup>47</sup>

This list of predicates has been elaborated basing on a sample taken from *Corsyntax* browser (Landa 2008), which is, in turn, fed from the corpus *Contemporary Reference Prose* (Sarasola et al. 2011).

#### 4.2.1.1. PREDICATES DERIVED FROM EVENT NAMING ROOTS

These are some examples of denominal predicates:

##### (23) DENOMINAL PREDICATES

|                                           |             |                               |
|-------------------------------------------|-------------|-------------------------------|
| aitortu 'to confess'                      | <b>from</b> | aitor 'confession'            |
| agurtu 'to greet'                         |             | agur 'greeting'               |
| argudiatu 'to argue'                      |             | argudio 'reason'              |
| arbuiatu 'to dismiss, to reject'          |             | arbuio 'rejection'            |
| abestu 'to sing'                          |             | abesti 'song'                 |
| aholkatu 'to advice'                      |             | aholku 'advice'               |
| amestu 'to dream'                         |             | amets 'dream'                 |
| abisatu 'to warn'                         |             | abisu 'warning'               |
| artatu 'to take care of sb, to assist sb' |             | arta 'attention, care'        |
| arrazoitu 'to reason'                     |             | arrazo 'reason'               |
| arnastu 'to breath'                       |             | arnas 'breath'                |
| arranguratu 'to complain'                 |             | arrangura 'sorrow, complaint' |
| arrantzatu 'to do fishing'                |             | arrantza 'fishing'            |
| bidaiatu 'to travel'                      |             | bidai 'travel'                |

<sup>47</sup> As I mentioned in chapter 3, the terms denominal and deadverbial have no theoretical status here.

|                                                 |                                |
|-------------------------------------------------|--------------------------------|
| bogatu 'to row'                                 | boga 'rowing'                  |
| dantzatu 'to dance'                             | dantza 'dance'                 |
| jolastu 'to play'                               | jolas 'play'                   |
| kantatu 'to sing'                               | kanta 'song'                   |
| abortatu 'to abort'                             | abortu 'abortion'              |
| jokatu 'to play, to bet, to act'                | joko 'game'                    |
| galdetu 'to ask'                                | galde 'question'               |
| deitu 'to call'                                 | dei 'call'                     |
| azpimarratu 'to underline'                      | azpimarra 'underline'          |
| aukeratu 'to choose'                            | aukera 'choice'                |
| kritikatu 'to criticize'                        | kritika 'criticism'            |
| hautatu 'to choose'                             | hautu 'choice'                 |
| frogatu 'to prove'                              | froga 'proof'                  |
| bultzatu 'to push'                              | bultza 'push'                  |
| ukitu 'to touch'                                | uki 'touch'                    |
| bozkatu 'to vote'                               | bozka 'vote'                   |
| gidatu 'to drive, to guide'                     | gida 'guide'                   |
| mugatu 'to limit'                               | muga 'limit'                   |
| lehiatu 'to compete, to dispute'                | lehia 'competition'            |
| markatu 'mark'                                  | marka 'mark'                   |
| epaitu 'to judge, to sentence'                  | epai 'judgement, verdict'      |
| borrokatu 'to fight'                            | borroka 'fight'                |
| eztabaidatu 'to discuss, to debate'             | eztabaida 'discussion, debate' |
| jorratu 'to weed, to discuss'                   | jorra 'weeding'                |
| bisitatu 'to visit'                             | bisita 'visit'                 |
| gurutzatu 'to cross'                            | gurutze 'cross'                |
| xuxurlatu 'to whisper'                          | xuxurla 'whisper'              |
| estreinatu 'to wear/perform for the first time' | estreina 'for the first time'  |

These denominal predicates differ from the denominals analyzed in chapter 1 in that they are built on Roots which name an Event, rather than a Property: their existence or meaning cannot be separated from that of the event.

For this reason, I claim that the LIs associated to the predicates listed above make their contribution to *proc*. They provide the *procP* node with lexical content. More specifically, I suggest that in the intransitive (unergative) variant of a predicate like *kantatu* ‘to sing’ (24), the LI *kanta* lexicalizes [<sub>procP</sub> proc Root]. The lexical entry of *kanta* is schematized below:

- (24) Mikel-ek oso ondo kanta-tu du  
 Michael-ERG very well song-TU have.3sgERG  
 ‘Michael has sung very well’

(25) *kanta* ↔ < /kanta/, procP, conceptual content >

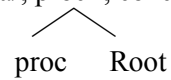

Thus, the decomposition of the predicate *kantatu* ‘to sing’ has the following shape:

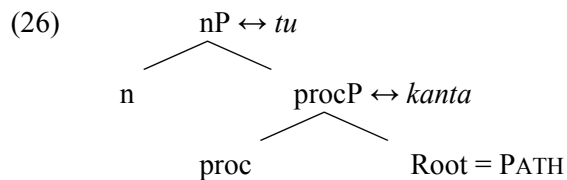

In intransitive predicates like (24), the process head selects a Root and the Root is interpreted as the PATH. The fact that Roots provide a measure for the event has been previously proposed in the literature (see for instance Harley 2005, Basilico 2010). Harley (2005) proposes an ontology of Roots classified according to three aspects: (i) whether they name a Thing, an Event or a State; (ii) whether they are bounded or unbounded; and (iii) whether they are complement taking or non-complement taking. This classification is schematized in the following table:

**Table 4.1.** The ontology of Roots (Harley 2005: 56)

|       | NO COMPLEMENT |              | COMPLEMENT   |             |
|-------|---------------|--------------|--------------|-------------|
|       | BOUNDED       | UNBOUNDED    | BOUNDED      | UNBOUNDED   |
| EVENT | <i>hop</i>    | <i>sleep</i> | <i>kick</i>  | <i>push</i> |
| THING | <i>foal</i>   | <i>drool</i> | N/A?         | N/A?        |
| STATE | <i>flat</i>   | <i>rough</i> | <i>clear</i> | ??          |

She proposes that the Roots in denominal verbs occupy a position identical to the position of certain measuring-out arguments, such as Incremental Themes. According to her, they originate in the sister position of *v*, and a homomorphic relation is established between them and the event. Thus, the meaning of the Roots determines the Aktionsart properties of the event, as incremental themes do.<sup>48</sup> Thus, for example, the incorporation of a Thing naming Root with a bounded property (like *foal*, *whelp* or *calf*) into *v* (in H&K’s terms) gives rise to a telic predicate in English:

<sup>48</sup> This is the position I assume for PATH objects.

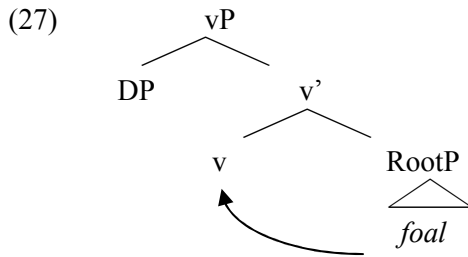

- (28) a. The mare foaled #for two hours/in two hours  
 b. The dog whelped #for two hours/in two hours  
 c. The cow calved #for two hours/in two hours

In contrast, a Thing naming Root with an unbounded property (like Roots denoting bodily emission fluids, such as *drool*, *sweat* or *blood*) result in atelic predicates:

- (29) a. The baby drooled for two hours/#in two hours  
 b. The athlete sweated for two hours/#in two hours  
 c. The wound bled for two hours/#in two hours

The same applies to Event naming Roots. Some Event naming Roots denote activities (e.g. *push*, *dance*), while others denote instantaneous events (e.g. *hop*, *flash*). She assumes that the difference between bounded and unbounded Thing naming Roots holds in Event naming Roots as well. Basing on Pustejovsky (1991) and Jackendoff (1991), she claims that linguistic Events are either point-like or extended for an arbitrary long time. Point-like denoting Event Roots are bounded, while those denoting an arbitrary long time are unbounded. When a bounded Event Root is incorporated into *v*, a homomorphic relation is established between them, and a semelfactive predicate is produced (30a).<sup>49</sup> In contrast, when an unbounded Event Root is incorporated into *v*, an activity is created (30b).

- (30) a. Sue hopped #for five minutes/#in five minutes  
 b. Sue danced for five minutes/#in five minutes

Building on this conception of Roots as measures, I claim that Event naming Roots like *kanta* represent the PATH object of the *proc* head. *Kanta* is associated with an [+incremental] measure *p*, consisting of ordered points denoting the progression of the song. This measure *p* is mapped to the temporal structure of the event.

- (31) song(*p*)  
 — + + + + + → ∞  
 0 1

<sup>49</sup> With an atelic frame adverbial (*for five minutes*), *hop* can be coerced to an iterative interpretation.

$$(32) \llbracket \text{song} \rrbracket = \{ \text{VAL}(p(i_n)) = \text{VAL}(p(i_{n-1})) + d \}$$

The numerical value of each point in the scale of  $\text{song}(p)$  is equal to the value of the anterior point plus an indefinite difference value. The event develops along the progression of the song. Earlier intervals in the running time of the event ( $\tau(e)$ ) match points of  $\text{song}(p)$  which involve shorter parts of the song and later intervals match points corresponding to longer parts.

$$(33) \begin{array}{cccccc} \tau(e): & t'_1 & t'_2 & t'_3 & t'_4 & t'_5 & t'_6 \\ & - & + & + & + & + & + \rightarrow \infty \\ p(e): & i_1 & i_2 & i_3 & i_4 & i_5 & i_6 \end{array}$$

In this way, the time goes on together with the progression of the song, giving rise to a dynamic event.

Incremental Event naming Roots like *kanta* ‘song’ have a lower bound. They need a time to be established (e.g. Dowty 1979, Landman & Rothstein 2012b). Crucially, they do not have an upper bound. The scale associated to them does not have a maximal value. This is indicated by the arrow in (33). As a consequence of not having an upper bound, the predicate emerging from this measure is interpreted as unbounded.

On the other hand, accomplishments built on this kind of predicates are different in this respect. Consider the events of singing a specific song, like the *Hator, hator* (a Basque Christmas song).

$$(34) \begin{array}{l} \text{Amets-ek } Hator, hator \quad kanta\text{-tu du} \\ \text{Amets-ERG } hator\text{-}hator\text{-ABS song-TU have.3sgERG.3sgABS} \\ \text{‘Amets has sung } Hator, Hator\text{’} \end{array}$$

In this event, the set of measures is provided by the direct object *Hator, hator* which can be schematized this way:

$$(35) \begin{array}{c} Hator, hator(p) \\ \text{--- -- -- -- --} + \\ 0 \qquad \qquad \qquad 1 \end{array}$$

The part-whole measure denoted by *hator, hator* is incremental like that of *kanta* ‘song’: later points correspond to bigger parts of the *hator, hator*. Nevertheless, unlike  $\text{kanta}(p)$ ,  $\text{hator, hator}(p)$  has an upper bound, and this point is the minimal point for the description of *hator-hator* to hold. Thus, its final point  $p(1)$  is the only point within the denotation of  $\llbracket hator, hator \rrbracket$ . This scale is similar to the scalar path of

terminatives (e.g. *ateraino* ‘up to the gate’) (Pantcheva 2011) and the scale of close-scale gradable properties like *dryness*(*p*) (see chapter 2, sec.2.1.3). Recall the definition of terminative paths proposed in chapter 1:

$$(36) \llbracket \text{terminative } p \rrbracket = \left\{ \begin{array}{l} p(1) \text{ is positive iff} \\ p(1) = p_n, \\ p_{n-1} \text{ is negative.} \\ \text{VAL}(p_j) = \text{VAL}(p_{j-1}) + d \text{ iff } p_j \neq p(1). \end{array} \right\}$$

The definition of terminatives also describes accomplishments like (34). This formulation states that as soon as there is a transition to a positive phase, the scale ends. The scale ends when the completion of the song is reached. Furthermore, it also indicates that each point preceding the final point *p*(1) corresponds to larger parts of the song than those corresponding to previous ones. This scale is mapped to the temporal progress of the event, and, this way, it yields a bounded event, an event that finishes when the *hator, hator* ends.<sup>50</sup>

Other predicates entering the activity/accomplishment alternation are sound emission predicates like *abestu* ‘to sing’, *kantatu* ‘to sing’, *xuxurlatu* ‘to whisper’ and activities like *jolastu* ‘to play’ and *borrokatu* ‘to fight’. On the other hand, some predicates listed in (22) are necessarily accomplishments, taking a direct object DP. Some of them are incremental theme predicates, e.g. *frogatu* ‘to prove’, *gurutzatu* ‘to cross’, *estreinatu* ‘to wear, to perform for the first time’, *azpimarratu* ‘to underline’, *aukeratu* ‘to choose’, *galdetu* ‘ask’. Others are predicates which take target-like objects: *bultzatu* ‘to push’, *kritikatu* ‘to criticize’, etc. Finally, a few predicates denoting activities appear necessarily in intransitive configuration, like *bidaiatu* ‘to travel’.

I suggest that the lexicalization process of these predicates is slightly different in the intransitive and transitive variants. In the intransitive, the LI *kanta* is first inserted

<sup>50</sup> In this sense, note that in a certain context, *sing hator-hator* can also be modified by an atelic frame adverbial:

(vii) Amets-ek hator-hator kanta-tu du bi minutu-z  
 Amets-ERG *hator-hator*.ABS song-TU have.3sgERG.3sgABS two minute-INSTR  
 ‘Amets has sung *Hator, Hator* for two minutes’

I claim that, in this case, *hator, hator* is understood as a type of song. This has a clear consequence for its scalar measure. The measure associated to *hator, hator* –where *hator, hator* is a type of song– has a lower bound. This means that a part of the *hator, hator* song is also considered a *hator, hator* song. Thus, in this context, the measure associated to the Rheme is similar to the measure associated to the open-scale *wide*. As commented in chapter 1, *wide* is fine with both telic and atelic temporal adverbials.

(viii) a. The gap widened in two minutes  
 b. The gap widened for two minutes



in the Root node and, then, in *procP*, in accordance with the Cyclic Spell Out, the Superset Principle and Phrasal Spell Out (see chapter 2). After *kanta* is inserted in *procP*, the previously inserted instance of the same LI is ignored.

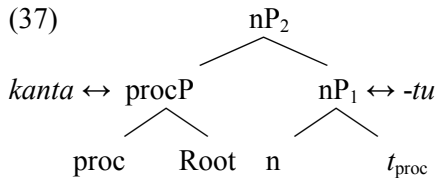

As can be seen, in this lexicalization, *-tu* only lexicalizes the nominalizing head (and its phrase node). In order for *-tu* to be inserted in *nP*, *procP* moves to the left of *nP* (according to Spell Out driven movement, Caha 2010) yielding the surface sequence of morphemes.

In the transitive variant, on the other hand, the DP object is in the complement position of *proc* –instead of the Root– and the LI corresponding to the stem is inserted directly in *procP*. The Root, contrary to what happens in intransitive sentences discussed previously, does not provide the measure of the event. The DP object does so: the DP is the PATH object which is identified with *proc* (see section 4.2.1.3).

Apart from the Roots discussed, there is another type of scalar Event naming Root that performs the role of PATH. As argued in Harley (2005), some Event naming Roots denote punctual events. I suggest that these Roots are associated to measures that have both lower and upper bounds, for example, the Roots *aborta* of *abortatu* ‘to abort’, *salta* of *saltatu* ‘to jump’ and *bozka* of *bozkatu* ‘to vote’.

- (38) a. Mikel-ek salta-tu du  
 Michel-ERG jump-TU have.3sgERG  
 ‘Michael has jumped’  
 b. Mikel-ek bozka-tu du  
 Michel-ERG vote-TU have.3sgERG  
 ‘Michael has voted’

The measures associated to these Roots can be graphically represented as follows:

- (39) aborting(p), jumping(p), voting(p)  
 — — + + — —  
 0 1

Consider the case of voting. The negative points preceding the positive ones can be defined as the preparatory steps for voting, like going to the school, putting the ballot inside the envelop etc. These points are not in the denotation of  $[[vote]]$  and do not

correspond to smaller parts of the voting event either. The points which are inside  $[[vote]]$  represent the moments of dropping the envelope inside the ballot box. This is the definition of a semelfactive predicate. Interestingly, Zwarts (2005) and Pantcheva (2011) make a similar scalar representation of transition Route paths like *through* and *past* which involve two transitions: from a negative phase to a positive one and from a positive one to a negative one. Zwarts (2005) actually claims that this kind of Route paths involves a scalar path similar to that of semelfactive predicates.

The mapping of the measure depicted in (38) to the temporal structure of *proc* triggers a telic interpretation of the predicate.

#### 4.2.1.2. DEADVERBIAL -KA PREDICATES

These are some examples of unergative and non-causative transitive predicates built on the basis of *-ka*:

##### (40) DERIVED FROM -KA ADVERBS

|                                             |             |                                 |
|---------------------------------------------|-------------|---------------------------------|
| aldarrikatu 'to announce, to proclaim'      | <b>from</b> | aldarri 'clamor' + ka           |
| harrikatu 'to stone'                        |             | harri 'stone' + ka              |
| tirokatu 'to shoot, to fire'                |             | tiro 'shot' + ka                |
| irudikatu 'to symbolize, to represent'      |             | irudi 'picture, image' + ka     |
| zeharkatu 'to span, to cross, to penetrate' |             | zehir 'through, across' + ka    |
| oihukatu 'to shout'                         |             | oihu 'shout' + ka               |
| zirikatu 'to provoke, to urge'              |             | ziri 'dig, curring remark' + ka |
| musukatu 'to kiss'                          |             | musu 'kiss' + ka                |
| galdekatu 'to question, to interrogate'     |             | galde 'question' + ka           |
| gudukatu 'to fight, to struggle'            |             | gudu 'fight, struggle' + ka     |

As can be observed, *-ka* is combined in the majority of cases with an Event Root (e.g. *aldarri* 'clamour' in *aldarrikatu* 'to proclaim'). In certain cases, it can also modify Thing naming Roots (e.g. *harri* 'stone' in *harrikatu* 'to stone').<sup>51</sup> As mentioned in chapter 1, I claim that *-ka* lexicalizes a Class(ifier)P node which has the function of portioning out the stuff denoted by its complement. When it is combined with complements associated to bounded measures like semelfactive Event naming Roots (e.g. *musu* 'kiss', *tiro* 'shot' etc.), it gives rise to an iterative interpretation. The

<sup>51</sup> See section 4.3 for the analysis of Thing naming Roots.

dividing function performed by *-ka*, triggers a repetition (a plural number of instances) of the measure associated to the Root.

Recall the lexical entry of *-ka* posited in chapter 1 (sec.3.1.2):

$$(41) \quad -ka \leftrightarrow \langle /ka/, \text{stateP} \rangle$$

```

stateP
├── state
└── ClassP

```

In unaccusative and causative predicates, when *proc* selects for the stateP lexicalized by *-ka*, the state becomes a result subevent. In the predicates of (40), in contrast, there is no result. I claim that *-ka* in these predicates lexicalizes only the node ClassP. This is a possible scenario according to the Superset Principle, which states that a LI can be inserted in a syntactic node if it contains a superset of the features present in the syntactic node. In the predicates listed in (40), the stateP feature of *-ka* would be left unused, then.<sup>52</sup>

The repetitive or iterative effect of *-ka* is observed in certain predicates like *harrikatu* ‘to stone’ and *tirokatu* ‘to shoot’, which denote events involving many stones or shots. In this respect, there is a nice contrast between the accomplishment *galdetu* ‘to ask’ (listed in section 4.2.1.1), and the activity *galdekatu* ‘to question, to interrogate’. *Galdetu* involves making just one question, and *galdekatu*, in contrast, more than one. The presence of *-ka* derives the change of meaning from ‘to ask’ (an accomplishment) to ‘to interrogate’ (an activity). The measure arising from *galdeka* can be schematized as follows:

$$(42) \quad galdeka(p)$$

```

— + + + + —→ ∞
0           1

```

It has a lower bound: a minimal point to be established, in this case, gathering more than one question. The measure is incremental: each point involves a larger amount of questions than the previous one. Finally, it has no upper bound: the questioning can go on and on with no natural endpoint. Thus, this scale is similar to that denoted by open-scale Property naming Roots (e.g. English *wide*) and Event naming Roots like *dantza* ‘dance’. When the measure arising from *galdeka* is put into an isomorphic relation

<sup>52</sup> This underassociation may be related to the fact that the complement of *-ka* in change of position predicates (e.g. *sail* ‘class’ in *sail-ka-tu* ‘to classify’) can be considered a Place, whereas its complement in the predicates analyzed in this chapter (e.g. *oihu* ‘shout’ in *oihu-ka-tu* ‘to shout’) is not.

with the temporal progress of the event, the resulting event is an unbounded predicate, an activity.

Consider an intransitive sentence like (43). This would be its syntactic/eventive decomposition:

- (43) Ane-k oihu-ka-tu du  
 Ane-ERG shout-KA-TU have.3sgERG  
 ‘Ane has shouted’

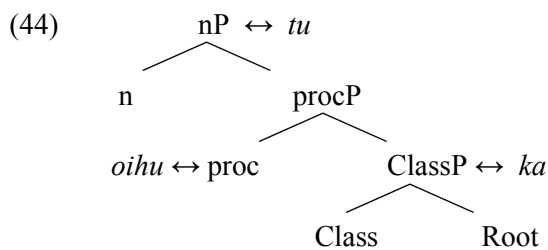

Let us analyze the lexicalization process step by step. The RootP is provided with lexical content: *oihu* ‘shout’. I suggest that the lexical entry of *oihu* is the following:

- (45) *oihu* ↔ </oihu/, proc, conceptual content>
- 
- ```

graph TD
  RootProc["</oihu/, proc, conceptual content>"] --- Root["Root"]
  RootProc --- proc["proc"]
  
```

The lexical entry of *oihu* is different from that of *dantza* in that *oihu* spells out a *proc* head to which the Root has been incorporated (instead of a whole *procP* node). When Class merges with Root and *ClassP* is projected, the lexicon is accessed again. In order for *-ka* to be inserted in *ClassP*, the Root has to move to its left, according to the Spell out driven movement (Caha 2010). Then, *proc* is merged, and the insertion of *oihu* in *proc* triggers the incorporation of the Root to *proc*. Finally, *n* merges to *procP* and *nP* is projected, and the insertion of *-tu* in *nP* triggers the evacuation of the whole *procP* to the left of *nP*.

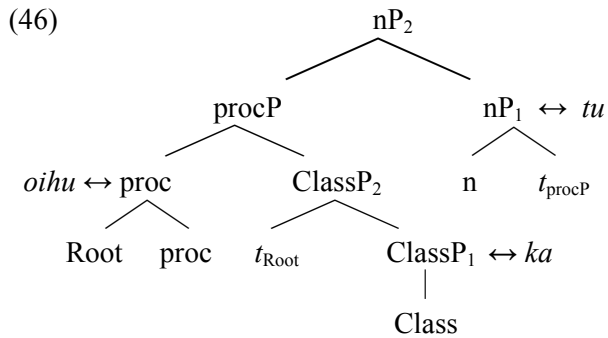

In this way, we get the surface sequence of the morphemes.

#### 4.2.1.3. COGNATES, HYPONYMS AND OTHER COMPLEMENTS

Most of the predicates analyzed in this chapter can appear in a transitive configuration. As a matter of fact, many of them obligatorily have to occur accompanied by a direct object. Among them, the case of derived verbs structured on *-ka* adverbials is remarkable: all the verbs listed, other than *oihukatu*, all others need to have a direct object.

These are some examples of the transitive uses of the verbs explored, taken from the *Dictionary of Contemporary Basque* (Sarasola in progress):

- (47) Herri-ko neska-mutil-ek udaberri-ko kantak eta dantzak abes-tu eta  
 town-GEN girl-boy-ERG spring-GEN songs.ABS and dances.ABS song-TU and  
 dantza-tu ohi zituzten arratsero  
 dance-TU PRT have.3plERG.3plABS.PST every-afternoon  
 ‘The boys and girls of the town used to sing and dance songs and dances every  
 afternoon’ [J. Morales (Nikolai Gogol) 1998: 400]
- (48) Ederki dantza-tu du ohorezko Aurreskua [Txillardegui, 1999: 361]  
 very-well dance-tu have.3sgERG honorable auresku.ABS  
 ‘He/she has danced very well the honor *auresku*’
- (49) -Apaiz bat? –galde-tu zuen Karmen-ek harrituta  
 priest a? question-TU have.3sgERG.PST Karmen-ERG surprised  
 ‘A priest? Asked Karmele surprised’ [I. Mujika Iraola, 1999: 8]
- (50) Jaka-ren poltsiko-an eskua sar-tu eta gutuna uki-tu  
 Jacket-GEN pocket-INE hand.ABS enter-TU and letter.ABS touch-TU  
 zuen  
 have.3sgERG.3sgABS.PST  
 ‘He/she put his/hand into his/her pocket and touched the letter’  
 [J. Urteaga2001: 260]

- (51) Etengabe kritika-tze-n zuen jendea  
 constantly criticism-TZE-INE have.3sgERG.PST people.ABS  
 ‘He/she constantly criticized people’ [P. Lizarralde (G. Celati), 2005: 37]
- (52) Polizia-k zorrozki galde-ka-tu-ko ditu  
 Police-ERG severely question-KA-TU-KO have.3sgERG.3plABS  
 ‘The police will severely interrogate them’  
 [M. Etxehandi (G. Joannateguy), 2003: 151]

As can be seen in these examples, the direct objects of the predicates make different semantic contributions. For instance, in the first three examples, with the predicates *dantzatu* ‘to dance’, *abestu* ‘to sing’ and *galdetu* ‘to ask’, the direct objects are cognates or hyponyms of the stems lexicalized in the predicates. Cognate objects are direct objects which share their Root with the predicate. Hyponyms, in contrast, have a different Root with respect to that of the predicate, but, nevertheless, denote an object which belongs to the class of things denoted by the Root of the predicate. Some schematized examples are shown below:

- (53) a. Dantza bat dantza-tu, abesti bat abes-tu, galdera bat galde-tu *Cognate*  
 dance a dance-TU, song a song-TU, question a question-TU  
 ‘dance a dance, sing a song, question a question’
- b. Aurrekua dantza-tu, aurrekua abes-tu, zalantza bat galde-tu,  
 aurreku dance-TU, aurreku song-TU, doubt a question-TU  
 izen bat oi-hu-ka-tu  
 name a shout-KA-TU  
 ‘dance the aurreku, sing the aurreku, question a doubt, shout a name’  
*Hyponym*

These objects are incremental themes. As I explained in section 4.2.1.1, they denote a measure whose scalar structure is homomorphic with the temporal progress of the event. If the dance, song, etc. is finished, the event is also concluded. Otherwise, if the dance, song etc. is partially performed, the event is also understood as not carried out to a terminus. I claim that in this case, the direct objects are the PATH arguments: they are the complements of *proc*. Thus, in a sentence like (54), the DPs (*dantza bat* ‘a dance’ and *tangoa* ‘a tango’) are in *proc*’s complement position.

- (54) a. Irati-k dantza bat / tangoa dantza-tu du  
 Irati-ERG dance a.ABS / tango a.ABS dance-TU have.3sgERG.3sgABS  
 ‘Irati has danced a dance/ a tango’

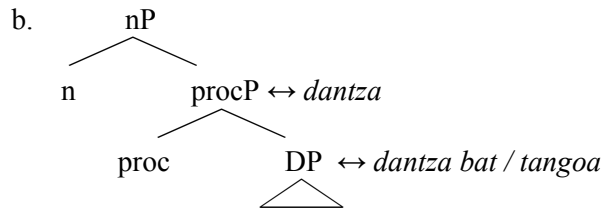

In the lexical entry of LIs like *dantza*, both *procP* and *RootP* nodes are specified.

(55) *-dantza* ↔ < /dantza/, *procP*, conceptual content >

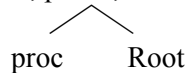

In the unergative structure, I have argued that the *Root*, lexicalized together with *procP*, is the *PATH* of the process subevent. In the transitive variant, in contrast, the *PATH* is the overt *DP* complement of *proc*. The *Root* feature specified in the lexical entry of *dantza* seems to be left unused, and substituted by the *DP* *tangoa/dantza*. This is possible given the Superset Principle (e.g. Starke 2009). Nevertheless, recall that Ramchand (2008b) proposes some Constraints on Underassociations of this type:

(56) Constraints on Underassociation (Ramchand 2008b: 129)

- a. Underassociation of category features of any ‘main verb’ is in principle possible, constrained by *AGREE*.
- b. *AGREE*-ing categorial features must unify their conceptual content.

According to Ramchand (2008b), in an English transitive predicate like *dance a jig*, the *N* feature specified in the lexical entry of *dance* is underassociated because it agrees with the *DP* complement. According to her, the conceptual content is successfully unified if the denotation of the *DP* is in a hyponym relation with *dance*.

Although these constraints seem to naturally apply in this context, they cannot be generalized to all activity/accomplishment alternations (see also section 4.2.2) For instance, some denominal predicates take *DP* *PATH* arguments which are not in a hyponym relation with their *DP* complement, but are, instead, *DPs* denoting spatial paths. For example, *saltatu* ‘to jump’, derived from *salto* ‘jump’ can take a *DP* complement like *zulo bat* ‘a hole’ and *zulo bat* is not a hyponym of *salto*. The same situation can be attested in the denominal predicate *jump* in English. As a consequence, the Constraints on Underassociation proposed by Ramchand (2008b) for denominal predicates like *dance* cannot be generalized to all denominal

unergative/transitive varying predicates. For this reason, I simply claim that in the case of transitive sentences like (55a), the LI *dantza* is directly inserted in procP, and that the Root node specified in its lexical entry is left unused.

Coming back to the examples presented at the beginning of this section, in the sentences (50), (51) and (52), repeated here, the direct object has another different function. It is not a cognate or a hyponymous argument and its scalar structure is not homomorphic to the temporal progress of the event. Instead, it expresses the target or goal of the event.

- (57) Jaka-ren poltsiko-an eskua sar-tu eta gutuna uki-tu  
 Jacket-GEN pocket-INE hand.ABS enter-TU and letter.ABS touch-TU  
 zuen  
 have.3sgERG.3sgABS.PST  
 ‘He/she put his/hand into his/her pocket and touched the letter’  
 [J. Urteaga2001: 260]

- (58) Etengabe kritika-tze-n zuen jendea  
 constantly criticism-TZE-INE have.3sgERG.PST people.ABS  
 ‘He/she constantly criticized people’ [P. Lizarralde (G. Celati), 2005: 37]

- (59) Polizia-k zorrozki galde-ka-tu-ko ditu  
 Police-ERG severely question-KA-TU-KO have.3sgERG.3plABS  
 ‘The police will severely interrogate them’  
 [M. Etxehandi (G. Joannateguy), 2003: 151]

In (57), “the letter” is the target of the touching; in (58), “people” is the target of the criticisms; and in (59), the non-overt direct object is understood as the target of the interrogation. These are some schematized examples.

- (60) a. Gutuna uki-tu  
 letter touch-TU  
 ‘Touch the letter’  
 b. Jendea kritika-tu  
 people criticism-TU  
 ‘Criticize people’  
 c. Atxilotua galde-ka-tu  
 prisoner question-KA-TU  
 ‘Interrogate the prisoner’  
 d. Jon musu-ka-tu  
 John kiss-KA-TU  
 ‘Kiss John repeatedly’

At the same time, the direct objects of these verbs are also interpreted as affected arguments. So, in (60a), the direct object is the target of ‘the touch’, but additionally, it undergoes the touching process. For the moment, I am not going to provide an



analysis of the configuration of these predicates, and just note that they are not PATH objects.

I will come back to the discussion of this kind of direct objects in section 4.2.3. Then, in section 4.4, I will discuss their aspectual and target-like properties, particularly, in the light of the dative/absolutive case marking variation attested on the object of these predicates (Etxepare 2003, Fernández and Ortiz de Urbina 2010 2012 in press).

#### 4.2.1.4. ON THE NON-DYNAMIC ‘SHINE’

Before finishing this section, I want to make a note on non-dynamic predicates like ‘shine’: for example, *distiratu* ‘to shine, to gleam’ (from *distira* ‘shine’) and *argitu* ‘to shine, to gleam’ (from *argi* ‘light’) in Basque. They are derived from Event naming Roots<sup>53</sup>, but, unlike the predicates that I have analyzed until now, they do not take a PATH argument. In contrast, they take a non-dynamic Rheme.

I will deal with these and more non-dynamic/eventive verbs in chapter 4. As I will explain then, their lack of dynamicity is observed in that they are incompatible with the adverbs *astiro-astiro* ‘slowly’ and *apurka-apurka* ‘little by little’ (62). Compare the use of *distiratu* in these contexts with that of the verb *dantzatu* ‘to dance’.

- (61) Ane-k fandangoa dantza-tu du astiro-astiro  
 Ane-ERG fandango.ABS dance-TU have.3sgERG.3sgABS slowly  
 ‘Ane has danced fandango slowly’
- (62) \*Izarr-ek astiro-astiro / apurka-apurka distiratu dute  
 stars-ERG slowly / little by little shine-TU have.3plERG  
 ‘\*The stars have shined slowly/little by little’

Following Fábregas & Marín (to appear), I consider that the non-dynamicity is due to the lack of a PATH argument.

- (63)
- 
- ```

  graph TD
    nP[nP] --- n[n]
    nP --- procP["procP ↔ distira"]
    procP --- proc[proc]
    procP --- Root["Root ≠ PATH"]
  
```

<sup>53</sup> *Argitu* is homophonous with a predicate derived from a Property naming Root which means ‘to lighten or to illuminate’ (e.g. *lanparak gela argitu du* ‘the lamp has lightened the room’). See chapter 3 for an analysis of this kind of predicate.

The *proc* subevent selects for a Root, also lexicalized by the LI *distira*, but this Root does not represent a PATH object. I am assuming, then, that some complements of *proc* are not PATHS, as already advocated in Fábregas & Marín (to appear). I suggest that being or not a PATH object is determined by the type of measure associated to the Root. As I have shown in previous sections, Roots giving rise to dynamic predicates are monotonic and they allow being conceptualized as part of a change process: they either (i) can be viewed as consisting of points ordered incrementally, so that each point has a corresponding numerical value greater than the value corresponding to the previous point; or (ii) involve a transition to a different type of phase, that is to say, they have lower or upper bounds. The measure denoted by *distira* ‘shine’, in contrast, does not have any of these characteristics.

$$(64) \quad \llbracket \text{distira} \rrbracket = \left( \begin{array}{l} \text{VAL}(p(i_n)) = \text{VAL}(p(i_{n-1})) = \text{VAL}(p(i_{n+1})) \\ \text{Iff } p(i_n) \text{ is positive, then } p(i_{n-1}) \text{ and } p(i_{n+1}) \text{ are also positive.} \end{array} \right)$$

The numerical value of all points is the same and there is not a transition to a different phase.

$$(65) \quad \begin{array}{cccccccc} + & + & + & + & + & + & + & + \\ & & 0 & & & & & 1 \\ p(e): & i_1 & i_2 & i_3 & i_4 & i_5 & i_6 & i_7 \end{array}$$

Thus, a predicate emerging from the mapping of this type of measure to the temporal structure of *proc* is one in which the progression of the time does not involve a progression of the event. In other words, the event is static. I will analyze in detail this kind of predicate in chapter 6.

#### 4.2.1.5. SUMMARY OF CONCLUSIONS

As a summary, the different types of measures that are identified with *proc* are included in table 4.2.

Table 4.2. Ontology of measures

|                              |                       |                     |                        |
|------------------------------|-----------------------|---------------------|------------------------|
| MEASURES ARISING FROM RHEMES | EVENT NAMING ROOTS    |                     |                        |
|                              | + incremental         | – incremental       | – incremental          |
|                              | + lower bound         | + lower bound       | – lower bound          |
|                              | – upper bound         | + upper bound       | – upper bound          |
|                              | mono-transitional     | bi-transitional     | non-transitional       |
|                              | <i>dantza</i> ‘dance’ | <i>bozka</i> ‘vote’ | <i>distira</i> ‘shine’ |
|                              | Property naming Roots |                     |                        |
|                              | + incremental         | + incremental       | – incremental          |
|                              | + lower bound         | – lower bound       | – lower bound          |
|                              | – upper bound         | + upper bound       | – upper bound          |
| mono-transitional            | mono-transitional     | non-transitional    |                        |
| <i>handi</i> ‘big’           | <i>lehor</i> ‘dry’    | <i>ama</i> ‘mother’ |                        |
| -ka derived stems            |                       | Quantized DPs       |                        |
| + incremental                | + incremental         |                     |                        |
| + lower bound                | – lower bound         |                     |                        |
| – upper bound                | + upper bound         |                     |                        |
| mono-transitional            | mono-transitional     |                     |                        |
| <i>galdeka</i>               | <i>tangoa</i>         |                     |                        |

#### 4.2.2. Underived predicates

There are also several underived predicates appearing in the unergative and non-causative transitive configuration, although their number in my sample<sup>54</sup> is much smaller than that of derived ones. These are some examples taken from the sample and a few which have been added by myself. I have ordered them according to semantic classes, mostly following the classification made in Levin (1993). As can be observed, in this list there are several types of predicates denoting dynamic as well as non-dynamic activities, e.g. manner of motion predicates, consumption predicates and creation predicates. In this section, I will focus on the analysis of dynamic predicates, and leave non-dynamic ones for chapter 6.

<sup>54</sup> Recall that my sample consists of 440 predicates taken from the *Contemporary Reference Prose* corpus (Sarasola, Salaburu, Landa & Zabaleta 2001) ordered according to frequency rates of the *Corsintax* browser (Landa 2008) (see chapter 3, sec. 3.2.1)

## (66) “CHASE” PREDICATES

*jarraitu/jarraiki* ‘to follow’, *segitu* ‘to follow’

## (67) MANNER OF MOTION

*arrastratu* ‘to drag’, *korritu* ‘to run’, *ibili* ‘to walk’, *eskiatu* ‘to ski’,  
*eskalatu* ‘to clim’

## (68) CREATION

*antzeztu* ‘to act, to perform’, *apuntatu* ‘to note’, *idatzi* ‘to write’, *sinatu*  
‘to sign’, *eraiki* ‘to build’, *sortu* ‘to create’, *inprimatu* ‘print’.

## (69) PREDICATES OF ASSESSMENT OR STUDYING

*aztertu* ‘to analyze, to examine’, *arakatu* ‘to examine/to seach’, *analizatu*  
‘to analyze’, *deskribatu* ‘to describe’, *ikertu* ‘to investigate’, *ikasi* ‘to  
study’, *irakurri* ‘to read’

## (70) PREDICATES OF COMMUNICATION

*esan* ‘to say’, *artikulatu* ‘to pronounce’, *aipatu* ‘to mention’, *agindu* ‘to  
promise/to order’, *salatu* ‘to report, to denounce, to inform on’, *kontatu*  
‘to tell, to count’, *goraipatu* ‘to praise, to acclaim’, *alabatu* ‘to praise’,  
*deklaratu* ‘to declare’,...

## (71) PREDICATES OF INGESTING

*jan* ‘to eat’, *edan* ‘to drink’, *murtxikatu/mastekatu* ‘to chew’, *kontsumitu*  
‘to consume’, *bazkaldu* ‘to have lunch’, *afaldu* ‘to have dinner’.

## (72) PREDICATES RELATED TO SOCIAL INTERACTIONS

*defendatu* ‘to protect / to defend’, *tratatu* ‘to treat’, *akusatu* ‘to accuse’,  
*aurkeztu* ‘to present’

## (73) “THROW” PREDICATES

*jaurtiki/aurtiki* ‘to throw’

## (74) “GOVERN” PREDICATES

*gobernatu* ‘to govern’, *erreinatu* ‘to reign’, *administratu* ‘to  
administrate’, *kudeatu* ‘to coordinate’, *kontolatu* ‘to control’.

Lots of them are Romance loan predicates (e.g. *arrastratu* ‘to drag’, *apuntatu* ‘to note’, *gobernatu* ‘to govern’, *eskalatu* ‘to claim’).<sup>55</sup> In those cases, both the Root and the thematic vowel are borrowed (Berro & Etxepare to appear).

- (75) Miren-ek ez d-u eskia-tze-n (Spanish: *esqui-a-r* « to ski »)  
 Miren-ERG no have.3sgERG ski-TZE-INE  
 “Miren does not go skying”

In many of them, although a nominal cannot be clearly separated from the *-tu* morpheme, the LI lexicalizing the stem can also appear in elements of nominal category, as for example, *sina-tu* ‘to sign’ and *sinadura* ‘signature’, *apunta-tu* ‘to note’ and *apunte* ‘note’, *antzez-tu* ‘to perform’ and *antzerki* ‘play, theater’, to act’, *eskia-tu* ‘to ski’ and *eski* ‘ski’, *idatz-i* ‘to write’ and *idazki* ‘writing’, *eraiki* ‘to build’ and *eraikin* ‘building’ etc. In the transitive use of some of these predicates, the predicate and their direct object are in hyponymous relation.

- (76) a. Mikele-k idazlan bat idatz-i du gaur  
 Michael-ERG writing a.ABS write-TU have.3sgERG.3sgABS today  
 ‘Michael has written an essay today’  
 b. Ipuin gogoangarri bat idatzi zuen [zikoinari buruz]  
 story memorable a.ABS write-TU have.3sgERG.PST [about the stork]  
 ‘He/she wrote a memorable story about the stork’  
 [P.Zubizarreta, 2005:14]  
 b. Amets-ek etxe bat eraiki du [jostailuzko piezatxoekin]  
 Amets-ERG house a.ABS build.TU have.3sgERG.3sgABS [with toy little pieces]  
 ‘Amets has build a house with toy little pieces’  
 c. Jonek eta Mikel-ek obra bat antzez-tu dute  
 John-ERG and Michael-ERG piece a.ABS perform-TU have.3plERG.3sgABS  
 ‘John and Michael have performed a piece’

In these sentences, the direct objects are hyponyms (or even a cognate in (76a)) of the class of elements denoted by the root of the verb: *idazlan* ‘writing’ is a cognate/hyponym of the noun *idazki* ‘writing’; *ipaina* ‘a story’ is a hyponym of *idazki* ‘writing’; *etxe bat* ‘a house’ is a hyponym of the noun *eraikin* ‘building’; and finally, *obra bat* ‘a piece’ is a hyponym of *antzerki* ‘a play, theater’. The direct objects are, thus, PATH objects of the process subevent.

On the other hand, as mentioned in section 4.2.1.3, some of these predicates may also take PATH complements denoting spatial paths.

<sup>55</sup> See Alberdi (2003) for a study about the unergative/unaccusative alignment of loan predicates in Basque.

- (77) a. *Sei orrialde idatz-i ditut* [M.Etxebarria (J.P.Sartre), 2004: 108]  
 Six page write-TU have.1sgERG.3plABS  
 ‘I have written six pages’
- b. *Paperak sinatu dituzte* [M.Etxehandi (G.Joannateguy), 2003: 112]  
 papers.ABS sign-TU have.3plERG.3plABS  
 ‘They have signed the papers’
- c. *Jon-ek horma hau eskala-tu du*  
 John-ERG wall this.ABS climb-TU have.3sgERG.3sgABS  
 ‘John has climbed this wall’
- d. *Jon-ek Herri Krosa korri-tu du*  
 John-ERG cross-contry.ABS run-TU have.3sgERG.3sgABS  
 ‘John has run the popular cross country’

The direct objects are understood in those cases as the location of the writing, the signature, the climbing or the running. In any case, *sei orrialde* ‘six pages’, *paperak* ‘the papers’, *agiri bat* ‘a document’, *horma hau* ‘this wall’ and *Herri Krosa* ‘the popular cross-contry’ serve as spatial delimiters of the event and must be, consequently, considered PATHS.<sup>56</sup>

Finally, in other cases, such as in consumption predicates and predicates of assessments and studying, the direct object is a DP denoting an entity whose part-whole structure is homomorphic with the progression of the event.

- (78) a. [2003. urtean], *Ertzaintzak 71.202 delitu eta falta iker-tu*  
 [in 2003], ertzaintza-ERG 71,202 crime and misconduct investigate-TU  
 zituen  
 have.3sgERG.3plABS.PST  
 ‘In 2003, the Ertzaintza investigated 71,202 crimes and misconducts’  
 [Berría, 2004-01-14]
- b. *Urduritasunak jota, tarta osoa ja-n nuen*  
 [very nervous], cake whole.ABS eat-TU have.1sgERG.3sgABS.PST  
 ‘I was so nervous that I ate the whole cake’ [F.Rey (G. Celati), 2005: 13]
- c. *Hiru esaldi irakurr-i zituen*  
 three sentence read-TU have.3sgERG.3plABS.PST  
 ‘He/she read three sentences’

As in previous examples, in the sentences of (78), the direct objects also measures the event expressed by the predicate. For instance, *ikertu* ‘to investigate’, *jan* ‘to eat’ and *irakurri* ‘to read’ are atelic activities, but when they are combined with a bounded DP, like ‘a certain number of crimes’, ‘a cake’ or ‘three sentences’, they become telic

<sup>56</sup> Recall that I am making a distinction between PATHS (dynamic Rhemes) and spatial paths. PATHS can be bounded or unbounded, depending on whether the measure associated to them has an upper bound.

accomplishments. In this way, the process of the event is defined in terms of the scalar structure of the direct objects.

Some of the predicates listed above can occur in the unergative configurations, without any direct object:

- (79) a. Miren-ek astebururo eskia-tze-n du  
 Mary-ERG every-weekend ski-TZE-INE have.3sgERG  
 ‘Mary goes skiing every weekend’  
 b. Jonek oso ondo eskala-tze-n du  
 John-ERG very well climb-TZE-INE have.3sgERG  
 ‘John climbs very well’
- (80) a. Ane-k 14:00etan bazkaldu du  
 Ane-ERG 14:00-ine have-lunch-TU have.3sgERG  
 ‘Ane has had lunch at 14:00’  
 b. Amets-ek oso goiz afal-tze-n du  
 Amets-ERG very early have-dinner-TZE-INE have.3sgERG  
 ‘Amets has dinner very early’

As I proposed for the unergative use of *dantz*, I claim that the LIs lexicalizing the stem (*eskia*, *eskala*, *korri*, *bazkal* and *afal*) lexicalize both the process subevent and the Root, where the Root is interpreted as the PATH.

- (81)
- $$\begin{array}{c}
 \text{nP} \leftrightarrow -tu \\
 \swarrow \quad \searrow \\
 \text{n} \qquad \text{procP} \leftrightarrow \text{eskala-} \\
 \qquad \swarrow \quad \searrow \\
 \text{proc} \qquad \text{Root} = \text{PATH}
 \end{array}$$

Nevertheless, the measure associated to the PATH is different in the predicates in (79) and (80). For instance, the measure denoted by *korri* ‘run’ does not have an upper bound, whereas that denoted by *bazkal* ‘lunch’ does. For this reason, the predicate *bazkaldu* ‘to have lunch’ denotes an accomplishment without the need of a direct object DP, contrary to *korritu* ‘to run’. *Korritu* ‘to run’ needs to be combined with a DP associated to a measure having an upper bound (e.g. (77d)) to be telic. (See, in this sense, section 3.2).

This is not the end of the story. As it happened with derived predicates, the direct objects of some predicates do not enter into a homomorphic relation with *proc*, and cannot be, thus, considered PATH arguments. In the following section (2.3), I propose a different generating position, along the lines of Harley (2005).

### 4.2.3. Non-homomorphic direct objects

When I have analyzed derived and underived predicates (section 2.1. and 2.2), I have pointed out that some direct objects are not PATHs. They are not associated to a measure which is mapped to the temporal progress of the event. These are some examples of these objects combined with derived predicates (82) and underived predicates (83):

- (82) a. Ane-k Mikel bultzatu du  
 Ane-ERG Michael.ABS push-TU have.3sgERG.3sgABS  
 ‘Ane has pushed Michael’
- b. Jonek Mikel kritikatu du  
 John-ERG Michael.ABS criticism-TU have.3sgERG.3sgABS  
 ‘John has criticized Michael’
- c. Polizia-k atxilotua galde-ka-tu du  
 police-ERG prisoner.ABS question-KA-TU have.3sgERG.3sgABS  
 ‘The police has interrogated the prisoner’
- d. Mikelek Jon musu-ka-tu du  
 Michael-ERG John.ABS kiss-KA-TU have.3sgERG.3sgABS  
 ‘Michael has kissed John repeatedly’
- (83) a. Mikelek Jon defenda-tu zuen  
 Michael-ERG John.ABS defend-TU have.3sgERG.3sgABS.PST  
 ‘Michael defended John’
- b. bahitzaile-ek ongi trata-tu zute-la [jakinarazi zuen]  
 kidnapers-ERG well treat-TU have.3plERG.3sgABS-CMP [he/she indicated]  
 ‘He/she indicated that the kidnapers treated him/her properly’  
 [Berria, 2004-11-21]
- c. Jon-ek pilota jaurtiki zuen  
 John-ERG ball.ABS throw-TU have.3sgERG.3sgABS.PST  
 ‘John throw the ball’

The direct objects occurring with derived predicates in (82) can be considered targets or goals, but at the same time affected arguments. The direct objects of underived predicates, in contrast, are not interpreted as targets, but have, like the direct objects of derived predicates, an affected interpretation.

All these predicates belong to the class of non-causative transitive verbs, because they do not denote any change of state or position of the direct object, so that their internal argument must not originate in the specifier of a state subevent. However, the direct object is somehow affected by the event denoted by the root. We cannot postulate that it originates in the sister position of *proc*, since that would generate an object-event homomorphism. That would be the position of a PATH. Recall, additionally, that I have assumed that *proc* does not take any specifier argument



(against Ramchand 2008a but in accordance with other related proposals like Mateu 2002 and Cuervo 2003). I will follow Cuervo (2003) and Harley (2005) and claim that the direct object of these predicates originate in the complement position of the Root (see also Zagana 2005 for a related analysis of non-Path objects in predicates of communicative activity).

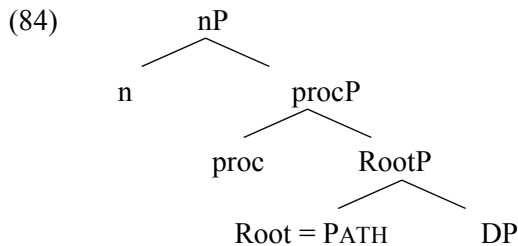

Harley (2005: 51-52) shows that the direct objects of predicates such as *push*, *drive* and *kick* are not measures:

- (85) a. John pushed the cart for five minutes/#in five minutes  
 b. Sue drove the car for five minutes/#in five minutes  
 c. Sue kicked the wall #for five minutes/#in five minutes

The definite objects *the cart*, *the car*, *the wall* and *Sue* do not give rise to the measure-event homomorphism discussed in sections 4.2.1 and 4.2.2. As a consequence of this contrast, Harley (2005: 52) suggests that they occupy a derived ‘object’ position, and not the “sister to v” position, which generates, according to her, the object-event homomorphism.

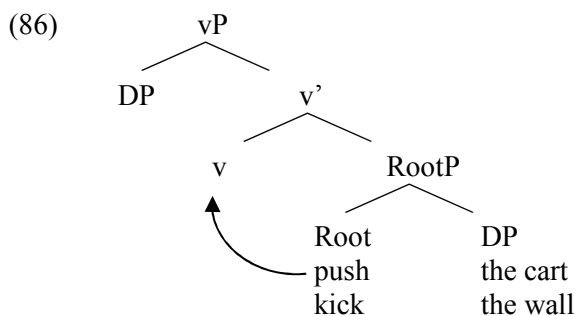

The DP objects are the complements of the Root. According to Harley (2005: 52) “the DP which ultimately ends up checking accusative case, then, is *not* in the base-generated direct-object position of the verb. That position –sister to v– which produces the event-object homomorphism is occupied by  $\sqrt{P}$  [RootP], whose boundedness

properties are those of the Root. Since the Root names an Event, then, the homomorphism mechanism will produce a punctual semelfactive like *kick* or an activity like *push*".

In (82) and (83), I have presented three types of predicates which take this kind of direct object: (i) denominal predicates, like *bultzatu* 'to push'; (ii) deadverbial predicates like *galdekatu* 'to interrogate'; and (iii) non-derived predicates like *jautiki* 'to throw'. Like in English, even if the direct object is a definite DP, atelic predicates like *kritikatu* 'to criticize', *galdekatu* 'to interrogate' and *musukatu* 'to kiss (repeatedly)' keep their atelicity:

- (87) a. Jonek Mikel kritikatu du bi ordu-z/  
 John-ERG Michael.ABS criticism-TU have.3sgERG.3sgABS two hours-INSTR/  
 ??bi ordu-tan  
 ??two hours-INE  
 'John has criticized Michael for two hours/ ?in two hours'
- b. Polizia-k atxilotua galde-ka-tu du bi ordu-z/  
 police-ERG prisoner.ABS question-KA-TU have.3sgERG.3sgABS two hours-INSTR/  
 ??bi ordu-tan  
 ??two hours-INE  
 'The police has interrogated the prisoner two hours/ ?in two hours'
- c. Mikelek Jon musu-ka-tu du bi ordu-z/  
 Michael-ERG John.ABS kiss-KA-TU have.3sgERG.3sgABS two hours-INSTR/  
 ??bi ordu-tan  
 ??two hours-INE  
 'Michael has kissed John repeatedly for two hours/?in two hours'

I suggest that the non-homomorphic relation between *proc* and the direct object of these predicates can be accounted along the lines suggested for the verbs *push* and *kick* in Harley (2005).

In denominal predicates and in non-derived predicates, the *proc* subevent selects a RootP. The Root takes a complement DP.

- (88) Transitive structure with affected (non-Paths) objects

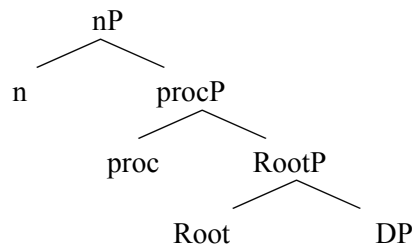

Since it is the whole RootP, headed by Root, which is in complement position of *proc*, the Root (or the object projected in the complement position of *proc*) is the element determining the dynamicity or non-dynamicity of the event, as well as its bounded or unbounded nature.

Regarding the decomposition of transitive deadverbial predicates like *galde-ka-tu* ‘to interrogate’, I suggest that in those cases, the *proc* subevent selects for ClassP associated with the interative meaning:

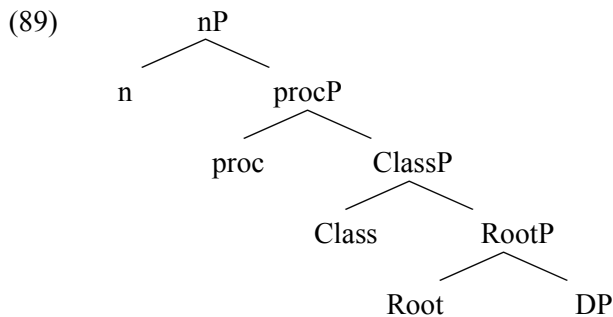

Since it is the ClassP which is in the complement position of the *proc*, Class is in a homomorphic relation with the event. The presence of the Class head above a Root such as *galde* (associated to a measure having an upper bound) triggers an iterative meaning and, as a consequence, the whole predicate is interpreted as iterative, as suggested in section 4.2.1 (*galde-ka-tu* ‘interrogate’ = making many questions vs. *galde-tu* ‘ask’ = making a single question).

In section 4.4, I will continue discussing the aspectual interpretation of this kind of predicates, particularly in relation to the dative/absolute marking alternation of the object.

### 4.3. MORPHOLOGICALLY COMPLEX UNERGATIVE PREDICATES

As noted in section 1, most unergative predicates in Basque are morphologically complex. They consist of the light predicate *egin* 'do' and an additional element, usually a bare noun, which specifies the kind of event. In this section, I will analyze the decomposition and lexicalization of these predicates, focusing, precisely, in the type of Root selected in these constructions, and in certain properties of the light predicate *egin* which differentiate this kind of unergative predicates from the rest analyzed so far in this chapter.

This is a list of several complex unergative predicates, taken from Etxepare (2003) and Zabala (2004), classified according to semantic classes:

#### (90) Emission verbs

##### a. SOUND EMISSION

|                          |             |                  |
|--------------------------|-------------|------------------|
| deiadar egin 'to scream' | <b>from</b> | deiadar 'scream' |
| oihu egin 'to shout'     |             | oihu 'shout'     |
| auhen egin 'to lament'   |             | auhen 'lament'   |
| intziri egin 'to moan'   |             | intziri 'moan'   |
| barre egin 'to laugh'    |             | barre 'laugh'    |
| negar egin 'to cry'      |             | negar 'cry'      |
| zurrunga egin 'to snore' |             | zurrunga 'snore' |
| zaunka egin 'to bark'    |             | zaunka 'bark'    |

##### b. LIGHT EMISSION

|                                       |
|---------------------------------------|
| dir-dir egin 'to shine'               |
| diz-diz egin 'to glow, to sparkle'    |
| nir-nir egin 'to twinkle, to flicker' |

##### c. VERBAL EMISSION

|                                       |                                  |
|---------------------------------------|----------------------------------|
| hitz egin 'to talk'                   | hitz 'word'                      |
| solas egin 'to talk, to chat'         | solas 'talk, chat'               |
| marmar egin 'to grunt'                | marmar 'grumble'                 |
| dei egin 'to call'                    | dei 'call'                       |
| otoitz egin 'to pray'                 | otoitz 'prayer'                  |
| errieta egin 'to reprimend, to scold' | errieta 'reprimand, telling-off' |
| burla egin 'to mock, to make fun of'  | burla 'mockery'                  |
| agur egin 'to greet'                  | agur 'greeting'                  |
| mehatxu egin 'to threaten'            | mehatxu 'threat'                 |

## (91) Mental activities

|                              |                      |
|------------------------------|----------------------|
| gogoeta egin 'to meditate'   | gogoeta 'meditation' |
| duda egin 'to doubt'         | duda 'doubt'         |
| amets egin 'to dream'        | amets 'dream'        |
| kasu egin 'to pay attention' | kasu 'attention'     |

## (92) Behavioral activities

|                                                    |                 |
|----------------------------------------------------|-----------------|
| planto egin 'to stop by refusing following a game' |                 |
| paso egin 'to be uninterested'                     |                 |
| muzin egin 'to be unfriendly, disdainful'          | muzin 'grimace' |
| uko egin 'to refuse, to reject'                    | uko 'refusal'   |

## (93) Internal body motion

|                           |
|---------------------------|
| dar-dar egin 'to tremble' |
| bor-bor egin 'to boil'    |

## (94) Physical activities

## a. ACTIONS AGAINST AN OBJECT OR AN INDIVIDUAL

|                         |                  |
|-------------------------|------------------|
| zizt egin 'to puncture' | zizta 'puncture' |
| putz egin 'to blow'     | putz 'blow'      |
| bultza egin 'to push'   | bultza 'push'    |
| laztan egin 'to caress' | laztan 'caress'  |
| tiro egin 'to shoot'    | tiro 'shot'      |
| min egin 'to hurt'      | min 'pain'       |
| txalo egin 'to clap'    | txalo 'clap'     |

## b. MOTION PREDICATES

|                        |                 |
|------------------------|-----------------|
| alde egin 'leave'      | alde 'distance' |
| ihes egin 'to flee'    | ihes 'flee'     |
| salto egin 'to jump'   | salto 'jump'    |
| dantza egin 'to dance' | dantza 'dance'  |
| laprast egin 'to slip' |                 |
| irrist egin 'to slip'  |                 |
| ospa egin 'to slip'    |                 |

## c. BODILY FUNCTIONS

|                          |                  |
|--------------------------|------------------|
| eztul egin 'to cough'    | eztul 'cough'    |
| aharrausi egin 'to yawn' | aharrausi 'yawn' |

|                           |                   |
|---------------------------|-------------------|
| lo egin 'sleep'           | lo 'sleep'        |
| kaka egin 'to shit'       | kaka 'shit'       |
| pixa/txiza egin 'to piss' | pixa/txiza 'piss' |
| botaka egin 'to vomit'    | botaka 'vomit'    |
| izerdi egin 'to sweat'    | Izerdi 'sweat'    |

## (95) Other types of activities

|                     |                       |
|---------------------|-----------------------|
| lan egin 'to work'  | lan 'work'            |
| huts egin 'to fail' | huts 'mistake, error' |

## (96) Weather predicates

|                            |                         |
|----------------------------|-------------------------|
| euria egin 'to rain'       | huri 'rain'             |
| eguzkia egin 'to be sunny' | eguzki 'sun'            |
| elurra egin 'to snow'      | elur 'snow'             |
| hotz egin 'to be cold'     | hotz (adjective) 'cold' |
| bero egin 'to be warm'     | bero (adjective) 'warm' |

As can be seen, the majority of complex unergative predicates consist of a bare nominal (e.g. *lan* 'work' in *lan egin* 'to work'), but there are some which take a Root as complement that is not used as a nominal in other contexts, as for example *dar-dar egin* 'to tremble' or *diz-diz egin* 'to sparkle', *laprast egin* 'to slip' and *ospa egin* 'to leave'.<sup>57</sup> Although I have not listed them here, a few can take a DP as complement (e.g. *etzula egin* 'to cough', *harrikoa egin* 'to do the washing up', *ohea egin* 'to do the bed', *bizarra egin* 'to shave oneself'). In those cases, the DP does not have a referential use and must have a generic reading (Zabala 2004: 471).

- (97) a. Jonek harrikoa egi-n du goizean  
 John-ERG washing-up do-TU have.3sgERG morning-INE  
 'John has done the washing up this morning'
- b. \*Peru-k aste oso-ko harrikoak egi-n ditu<sup>58</sup>  
 Peru-ERG week whole-gen washing-ups do-TU have.3sgERG.3plABS  
 'Peru has done the washing up-s of the whole week'
- c. \*Peru-k harriko hori egi-n du  
 Peru-ERG washing-up this.abs do-TU have.3sgERG  
 'Peru has done that whashing up'

In other cases, the complement can be optionally headed by the inessive adposition or *-ka* (Etxepare 2003, Preminger 2012):

<sup>57</sup>In the list above, I have provided the nominal complement for each predicate in the right-hand column. The ones which take a bare Root as complement have an empty space in that column.

<sup>58</sup>For some speakers, the example in (99b) does not sound as bad as (99c). This might point out that in some cases, *harrikoa* 'washing up' can be used in a referential way within the *egin* complex predicate.

- (98) a. Dantza(n) egi-n du  
 dance-(INE) do-TU have.3sgERG  
 ‘(S)he has danced’  
 b. Oihu(ka) egi-n du  
 shout-(KA) do-TU have.3sgERG  
 ‘(S)he has showed’

In some cases, the use of the adposition or the *-ka* adverbial is necessary:

- (99) a. Txakurra-k hagin-ka egi-n dit  
 dog-ERG molar-(KA) do-TU have.3sgERG.1sgDAT  
 ‘The dog has bited me’  
 b. Txoria-k hega-n egi-n du  
 bird-ERG wing-INE do-TU have.3sgERG  
 ‘The bird has flyed’

According to Etxepare (2003) and Preminger (2012), in the presence of the inessive adposition or *-ka*, the event denoted by the entire predicate has an iterative or repetitive interpretation. *-Ka*, therefore, gives rise to the same interpretation as in morphologically simplex predicates.

Regarding the aspectual classes of these complex predicates, generally speaking, it seems that they are all eventive, except the group of weather verbs, which can be considered stative in some sense. For the moment, I will ignore this last group. I will come back to them in chapter 6, when I deal with D-states.

#### 4.3.1. The ontology of Roots and aspectual classes

Basque complex unergative predicates belong to different aspectual classes (Zabala 2004). In this section I show that the aspectual properties are derived from the type of Root selected by the light predicate *egin* ‘do’. Recall from section 4.2.1. that Roots can be classified according to the properties of their associated measures: (i) whether they name an Event or a Property; (ii) whether they are incremental or not; and (iii) whether they involve lower and upper bounds or transitions. The table corresponding to Event naming Roots is repeated here, including in each cell examples of Roots found in complex unergative predicates.

**Table 4.3.** Ontology of Event naming Roots

|          |                                                                                                                              | EVENT NAMING ROOTS                                                                                                                                               |                                           |                  |
|----------|------------------------------------------------------------------------------------------------------------------------------|------------------------------------------------------------------------------------------------------------------------------------------------------------------|-------------------------------------------|------------------|
| MEASURES |                                                                                                                              | + incremental                                                                                                                                                    | – incremental                             | – incremental    |
|          |                                                                                                                              | + lower bound                                                                                                                                                    | + lower bound                             | – lower bound    |
|          |                                                                                                                              | – upper bound                                                                                                                                                    | + upper bound                             | – upper bound    |
|          |                                                                                                                              | mono-transitional                                                                                                                                                | bi-transitional                           | non-transitional |
|          | <i>dantza</i> ‘dance’, <i>lan</i> ‘work’, <i>amets</i> ‘dream’, <i>laztan</i> , <i>deiadar</i> ‘scream’, <i>oihu</i> ‘shout’ | <i>salto</i> ‘jump’, <i>txalo</i> ‘clap’, <i>ihes</i> ‘flee’, <i>alde</i> ‘leaving’, <i>ospa</i> , <i>zizt</i> , <i>putz</i> ‘blow’, <i>planto</i> , <i>paso</i> | <i>dir-dir</i> ‘shine’, <i>lo</i> ‘sleep’ |                  |

In order to account for the picture of complex unergative predicates, another class of Roots has to be included: Thing naming Roots (Harley 2005). Within the class of Thing naming Roots, there can be distinguished three types.

**Table 4.4.** Ontology of Thing naming Roots

|          |                                                                      | THING NAMING ROOTS                                            |                  |
|----------|----------------------------------------------------------------------|---------------------------------------------------------------|------------------|
| MEASURES |                                                                      | + incremental                                                 | – incremental    |
|          |                                                                      | + lower bound                                                 | – lower bound    |
|          |                                                                      | + upper bound                                                 | – upper bound    |
|          |                                                                      | non-transitional                                              | non-transitional |
|          | <i>txiza/pixa</i> ‘piss’, <i>kaka</i> ‘shit’, <i>botaka</i> ‘vomite’ | <i>izerdi</i> ‘sweat’, <i>euri</i> ‘rain’, <i>elur</i> ‘snow’ |                  |

Roots selected in complex unergative predicates are Event naming and Thing naming.<sup>59</sup> As shown in section 4.2.1, the set of measures emerging from the Roots is combined via a homomorphic relation with the temporal progress of the event, and the aspectual properties of the event are shaped according to the properties of the measures. This, way, an event selecting for an Event Root associated to a [+incremental, + lower bound, – upper bound] becomes an activity:

$$(100) \text{ lan}(p), \text{ amets}(p)$$

$$\begin{array}{ccccccc} - & + & + & + & + & + & \rightarrow \infty \\ 0 & & & & & & 1 \end{array}$$

- (101) a. Mikel-ek etxe-an lan egi-te-n du  
 Michael-ERG house-ine work do-TZE-INE have.3sgERG  
 ‘Michael works at home’

<sup>59</sup> I am ignoring weather verbs (e.g. *bero egin* ‘to be warm’), where some Property naming Roots are used.



- b. Jon-ek amets egi-te-n du  
 John-ERG dream do-TZE-INE have.3sgERG  
 'John dreams'

In contrast, when an Event Root associated to a bi-transitional measure is selected by *proc*, a semelfactive event is derived:

- (102) *txalo*(p) 'clap', *ihes*(p) 'escape'

— — + + — —  
 0 1

- (103) a. Mikel-ek beti txalo egi-te-n du [pozik dagoenean]  
 Michael-ERG always clap do-TZE-INE have.3sgERG [when he's happy]  
 'Michael always claps when he is happy'  
 b. Mikel-ek beti ihes egi-te-n du [Jon ikustean]  
 Michael-ERG always escape do-TZE-INE have.3sgERG [when he sees John]  
 'Michael always escapes when he sees John'

Let us analyze now Thing naming Roots. Harley (2005) makes a characterization of Thing naming Roots in terms of their bounded/unbounded nature. She claims that the incorporation of a Thing naming Root with a bounded property (like *foal*, *whelp* or *calf*) into *v* (in H&K's terms) gives rise to a telic predicate in English, and that the incorporation of a Thing naming Root with an unbounded property, in contrast, (like Roots denoting bodily emission fluids, such as *drool*, *sweat* or *blood*) result in atelic predicates. Nevertheless, coming to Basque, the relation is not always as straightforward. For instance, consider the "unbounded" Roots *pixa/txiza* 'piss', *kaka* 'shit' and *botaka* 'vomit'. Contrary to what is expected, when these Roots are selected, the resulting predicate is telic.

- (104) Jon txiza egi-te-n ari da ⇒ Jon-ek txiza egi-n du  
 John.ABS piss do-TZE-INE PROG be.1sgABS John-ERG piss do-TU have.3sgERG  
 'John is pissing' 'John has pissed'  
 (105) Jon kaka egi-te-n ari da ⇒ Jonek kaka egin du  
 John.ABS shit do-TZE-INE PROG be.1sgABS John-ERG shit do-TU have.3sgERG  
 'John is shiting' 'John has shited'

The Root *izerdi* 'sweat', in contrast, behaves as it is expected and derives an atelic verb.

- (106) Jon izerdi egi-te-n ari da ⇒ Jonek izerdi egi-n du  
 John.ABS sweat do-TZE-INE PROG be.1sgABS John-ERG sweat do-TU have.3sgERG  
 'John is pissing' 'John has pissed'

I claim that the opposed behavior of these predicates is due to the fact that the set of measures is not directly derived from the inherent properties of the Root, and that pragmatic factors also influence the measure. Both *txiza* ‘piss’ and *izerdi* ‘sweat’ denote uncountable liquid with no lower bound or upper bound, but we know from world knowledge that *txiza* corresponds to an arbitrary small (and always limited) amount of liquid. The same happens with *kaka* ‘shit’ and *botaka* ‘vomit’. The amount of sweat, in contrast, does not have this restriction. For this reason, I suggest that the Roots *txiza*, *kaka* and *botaka* are associated with [+upper bound] measures, contrary to *izerdi* which is [–upper bound]. In this way, we can explain the telicity of the predicates which result when these Roots are combined with *egin*. Thing Roots associated with measures having [+incremental] and [+upper bound] properties give rise to accomplishments, while those having [–incremental] and [–upper bound] properties (e.g. *izerdi* ‘sweat’) yield non-dynamic predicates. This contrast is observed in the (in)compatibility with the predicate *bukatu* ‘to finish’:<sup>60</sup>

<sup>60</sup> Other cases of [–incremental] and [–upper bound] measures arising from Thing Roots are the weather predicates *euria egin* ‘to rain’ and *elurra egin* ‘to snow’. When these Roots are combined with *egin*, the resulting predicate is an atelic non-dynamic one:

- (ix) Elurra egi-te-n ari da ⇒ Elurra egi-n du  
 snow do-TZE-INE PROG be.3sgABS snow do-TU have.3sgERG  
 ‘It is snowing’ ‘It has snowed’
- (x) #Elurra egiten buka-tu du  
 snow do-TZE-INE finish-TU have.3sgERG  
 ‘\*It has finished snowing’

Note that in these weather predicates, the Root is headed by the determiner. I claim that the role of the determiner in this complex unergatives is not influencing the aspectual interpretation. For instance, the determiner may also occur heading Event naming Roots, like *eztul* ‘cough’, and it does not turn the event into a telic predicate either.

- (xi) Jon-ek eztul/eztul-a egi-n du  
 John-ERG cough/cough-DET do-TU have.3sgERG  
 ‘Jon has coughed’

There are also a few complex unergative predicates consisting of Thing naming Roots giving rise to [+incremental] [+lower bound] [+upper bound] measures: *ohea egin* ‘do the bed’ and *bizarra egin* ‘shave oneself, lit. do the beard’. In these cases, too, the Root is headed by the determiner -a. Nevertheless, note that the determiner is used non-referentially, as commented before (Zabala 2004). The predicates consisting of *bizarra* and *ohea* are interpreted as telic accomplishments, as can be observed from the lack of the perfect entailment of their progressive form, and from their compatibility with *bukatu* ‘to finish’.

- (xii) a. Aingeru bizarra egi-te-n ari da ⇒ Aingeru-k bizarra egi-n du  
 Aingeru.ABS beard do-TZE-INE PROG be.1sgABS Aingeru-ERG beard do-TU have.3sgERG  
 ‘Aingeru is shaving his beard’ ‘Aingeru has shaved his beard’
- b. Aingeru-k bizarra egi-te-n buka-tu du  
 Aingeru-ERG beard do-TZE-INE finish-TU have.3sgERG  
 ‘Aingeru has finished shaving his beard’

- (107) a. Txiza/kaka/botaka egi-te-n buka-tu du  
 piss/shit/vomit do-TZE-INE finish-TU have.3sgERG  
 ‘He/she has finished pissing/shiting/vomiting’  
 b. #Izerdi egi-te-n buka-tu du  
 sweat do-TZE-INE finish-TU have.3sgERG  
 ‘He/she has finished sweating’

All in all, paying attention to the properties of the measures arising from the Roots, I have been able to explain the different aspectual properties of *egin* unergatives. This supports the claim that in unergative predicates, the Roots are actually the Rheme complements of the *proc* head and that they shape the aspectual interpretation of the event by means of identification.

#### 4.3.2. The subeventive decomposition and lexicalization of *egin* unergatives

In the previous section, I have accounted for the aspectual class of complex unergative predicates claiming that the measure associated to the Roots is mapped to the temporal structure of the event. Now, I will propose an analysis about the syntactic configuration which allows this identification relation to be established.

If the Root determines the aspectual properties of the event, then, it must be occupying the complement position of *proc*. This is actually what I have proposed for the Roots in morphologically simple unergative predicates. Thus, I claim that the light predicate *egin* lexicalizes the *proc* head. On the other hand, *egin* is headed by *-n*, a non-productive variant of *-tu*. Following the analysis of *-tu* made in this chapter, I consequently consider that *egin* (or the *-n* in *egi-n*) also lexicalizes the nP node.

Consider the following sentence, with the complex unergative verb *igeri egin* ‘to swim’.

- (108) Anek igeri egi-te-n du  
 Ane-ERG swim do-TZE-INE have.3sgERG  
 ‘Ane swims’

- 
- (xiii) a. Aingeru ohea egi-te-n ari da                   ⇒ Aingeru-k ohea egi-n du  
 Aingeru.ABS bead do-TZE-INE PROG be.1sgABS    Aingeru-ERG bead do-TU have.3sgERG  
 ‘Aingeru is doing the bed’                           ‘Aingeru has done the bed’  
 b. Aingeruk ohea egi-te-n buka-tu du  
 Aingeru-ERG bead do-TZE-INE finish-TU have.3sgERG  
 ‘Aingeru has finished doing the bed’

The Root *igeri* ‘swimming’ is associated to an [+incremental], [+lower bound] and [–upper bound] measure, and therefore, when it is placed in complement position of *proc*, it is a PATH object.

(109) *igeri* ↔ </igeri/, Root [Event, +incr., +lower, –upper], conceptual content>

On the other hand, abstracting away from *-n* morpheme of *egin*, I claim that the lexical entry of *egin* looks like this.

(110) *egin* ↔ </egin/, procP >  
                                   |  
                                   proc

Both LIs are inserted in the process of lexicalization and the relevant evacuation movements apply, as suggested in chapter 3 and the previous sections of this chapter.

Note that in some predicates, the complement of *egin* is not a bare Root, but an element headed by *-ka* or the inessive *-n*. In those cases, the event gets interpreted as iterative (Etxepare 2003, Preminger 2012).

- (111) a. Dantza(n) egi-n du  
           dance-(INE) do-TU have.3sgERG  
           ‘(S)he has danced’  
       b. Oihu(ka) egi-n du  
           shout-(KA) do-TU have.3sgERG  
           ‘(S)he has showed’

For these cases, I suggest that, like in morphologically simple verbs, *proc* takes a ClassP as complement.

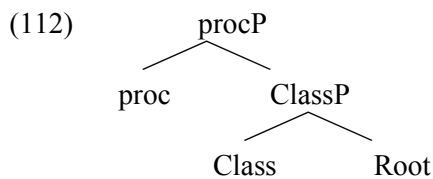

*-Ka* and the inessive *-n* combine with both Event and Thing Roots. For instance, *-n* combines with Event naming Roots like *dantza* ‘dance’ and with Thing naming Roots like *pilota* ‘ball’.

- (113) *Pilota-n egi-n dute*  
       ball-INE do-TU have.3plERG  
       ‘They have played handball’

On the other hand, *-ka* combines also with Event Roots –like the sound naming *marru* ‘moo’ in *marruka egin* ‘to moo’ and *oihu* ‘shout’ in *oihuka egin* ‘to shout’– and with Thing Roots, like *hagin* ‘molar’ in *haginka egin* ‘to bite’.<sup>61</sup>

- (114) a. Joxepa behia-k marru-ka egi-te-n du  
 Joxepa cow-ERG moo-KA do-TZE-INE have.3sgERG  
 ‘Joxepa the cow moos’  
 b. txakurra-k ez du hagin-ka egi-te-n  
 dog-ERG no have.3sgERG molar-KA do-TZE-INE  
 ‘The dog does not bite’

Note that, in the cases where *-n* and *-ka* select for a bounded Thing naming Root – in *pilota-n egin* ‘to play handball’ and *hagin-ka egin* ‘to bite’–, the resulting predicate is not an accomplishment, like in *ohea egin* or *bizarra egin*, but an atelic predicate. It seems that the presence of *-n* or *-ka* triggers a reading where the event is [–upper bound] and where the thing denoted by the Root is repeatedly involved.

### 4.3.3. The complementless restrictions and categorization

In section 4.3.2, I have suggested that *egi-n* lexicalizes both the process subevent and the nP node. Under this premise, then, it seems that *egin* lexicalizes exactly the same piece of structure spelled out by *-tu*. Consider, however, the unergative predicates *dantzatu* ‘to dance’ and *dantza egin* ‘to dance’. According to my previous analyses of the lexicalization of these predicates, in the simple variant, *-tu* is only lexicalizing [<sub>nP</sub> n] and *dantza* is spelling out both *procP* and the PATH. This differs from the lexicalization in *dantza egin*, where, according to my analysis, *egin* lexicalizes both *procP* and nP, and *dantza* spells out the PATH.

- (115) a. *dantza-tu*
- 
- b. *dantza egin*
- 

<sup>61</sup> It can also combine with elements which are used independently as adverbs, like *lasterka egin* ‘to run’, from *laster* ‘quickly’, and *arin-arinka egin* ‘to run’ from *arin-arin* ‘quickly’. I take the position that *laster* and *arin-arin* are Event naming Roots.

These different patterns of lexicalization explain a well-known property of *egin* unergatives: the fact that they cannot take a direct object (other than the Root). As noted in many works (e.g. Bobaljik 1993, Laka 1993a, Fernández 1997, Oyharçabal 2006), Zabala (2004: 477) claims that the complement of the *egin* light predicates saturates the internal argument position, and that any other argument cannot be syntactically realized bearing absolutive case. Neither a separated DP Rheme object, nor a non-homomorphic “affected” argument can occur in morphologically complex predicates.<sup>62</sup> Let us explain these restrictions step by step.

Morphologically simple predicates, as for example, *dantzatu* ‘to dance’, can take an overt DP argument realizing a PATH object. The parallel morphologically complex predicates, in contrast, cannot. Similarly, the simple version of the predicate *bultzatu* ‘to pull, to push’ takes an affected non-homomorphic argument, while the complex counterpart *bultza egin* does not.

- (116) a. Mikel-ek (tangoa) dantza-tu du  
 Michael-ERG (tango.ABS) dance-TU have.3sgERG.3sgABS  
 ‘Michael has danced (a tango)’  
 b. Mikelek (\*tangoa) dantza egi-n du  
 Michael-ERG (tango.ABS) dance do-TU have.3sgERG  
 Intended: ‘Michael has danced (a tango)’
- (117) a. Mikel-ek Jon bultza-tu zuen  
 Michael-ERG John.ABS push-TU have.3sgERG.3sgABS.PST  
 ‘Michael has pushed John’  
 b. Mikel-ek (\*Jon) bultza egi-n zuen  
 Michael-ERG (John.ABS) push do-TU have.3sgERG.3sgABS.PST  
 Intended: ‘Michael pushed John’

The syntactic complements of the *proc* head are the same in both the simple and the complex version of the predicates, but, the complex ones do not let an overt DP surface. I claim that this contrast is due to the fact that, in the simple variant, the LI *dantza* and *bultza* are lexicalized in *procP*, and, in contrast, in the complex one, they lexicalize Roots. This is reminiscent of some data found in Chol, a Mayan ergative

<sup>62</sup> There are some rare lexical exceptions to this restriction in eastern variants, as pointed out by Oyharçabal (2006:f6). For example, the semelfactive *huts egin* ‘to fail, to miss’ can take a PATH direct object:

- (xiv) Pello-k azken bi bilkurak huts egi-n ditu  
 Pello-ERG last two meetings fail do-TU have.3sgERG.3plABS  
 ‘Peter missed the last two meetings’

It may be that in this case, *huts egin* has become a morphologically simple verb: a single LI (*husegin*) which can be inserted directly in *procP*. In the discussion, I will ignore this kind of structure, since it is ungrammatical in most varieties.

language, and its analysis, put forward by Coon (2010). Coon (2010: 55) points out that "...all Chol verbs combine with a DP complement [...]. Those stems which do not combine with DP complements (unergatives and antipassives) must surface as nominals; they require a light verb in order to predicate". Let us see some examples of unergatives and non-causative transitives. Coon shows that an unergative stem like *soñ* 'to dance' cannot inflect as a verb; neither the ergative (set A marking) nor the absolutive agreement morpheme (set B marking) can appear directly attached to the stem:

- (118) a. \*Tyi soñ-i-yoñ  
 PRFV dance-ITV-B1  
 Intended: 'I danced'  
 b. \*Tyi k-soñ-i  
 PRFV A1-dance-ITV  
 Intended: 'I danced' (Coon 2010: 63)

In contrast, the Root *soñ* is grammatical if it is accompanied by the transitive light verb *cha`l*.

- (119) Tyi i-cha`l-e soñ  
 PRFV A3-do-DTV dance  
 'The woman danced' (Coon 2010: 58)

Remarkably, when *soñ* is combined with an object like *bals* 'waltz', verbal inflection appears directly attached to *soñ*, and the sentence is grammatical.

- (120) Tyi k-soñ-i bals  
 PRFV A1-dance-ITV waltz  
 'I danced a waltz'

Coon relates this contrast to the case assignment of the internal argument, by means of the following generalization:

- (121) Chol little *v* generalization (Coon 2010: 63)
- a. All internal arguments must be assigned (absolutive) Case by a *v* head;
  - b. All *v*'s must assign absolutive Case to an internal argument.

Thus, unergative stems are nominals, and not verbs, because they do not have a DP complement. In the case that they did, as in the latter construction shown (120), they become verbs, with case assigning properties and with the corresponding verbal inflection.

In this respect, let me make a clarification regarding Basque data. Recall that, in section 4.1.1, I pointed out that most unergative predicates in Basque are complex, as noted in many works (Uribe-Etxebarria 1989, Laka 1993a, Hale and Keyser 1993, Etxepare 2003, Oyharçabal 2006 and Aldai 2009). For instance, traditionally, in western and central varieties, the complex form is used as the unergative, and the simple form is restricted to the transitive construction. Nowadays, it is very common to find instances of the unergative use of simple predicates (which is the only possible option for loan verbs, see in this respect Alberdi 2003), but they still remain non-standard (not recommended uses according to Euskaltzaindia, the Royal Academy of the Basque language).<sup>63</sup>

## (122) Standard Basque

- a. Ane-k dantza egi-n du  
Ane-ERG dance do-TU have.3sgERG  
'Ane has danced'
- b. Ane-k tangoa dantza-tu du  
Ane-ERG tango.ABS dance-TU have.3sgERG.3sgABS  
'Ane has danced a tango'
- c. \*Ane-k dantzatu du  
Ane-ERG dance-TU have.3sgERG  
Intended: 'Ane has danced'
- d. Ane dantza-tu da  
Ane-ABS dance-TU be.3sgABS  
'Ane has danced'

Thus, it seems that the standard variety of Basque is similar to Chol: the Root *dantza* can be used: (i) in a complementless form, where it is accompanied by a light predicate *egin*; and (ii) in a complementing form, in which case it does not need *egin* and *-tu* directly attaches to it. What both the standard variety and the non-standard (western/central) varieties have in common is that they do not accept a structure where the Root is combined with the light *egin*, and, additionally, another DP is included.

- (123) a. Mikel-ek (\*tangoa) dantza egi-n du  
Michael-ERG (tango.ABS) dance do-TU have.3sgERG  
Intended: 'Michael has danced (a tango)'
- b. Mikel-ek (\*Jon) bultza egin zuen  
Michael-ERG (John.ABS) push do-TU have.3sgERG.3sgABS.PST  
Intended: 'Michael pushed John'

<sup>63</sup> In this dissertation, I am not going to address the example in (122d) which corresponds to the use of certain simple unergative predicates in north-eastern varieties.



Building on Coon (2010), I claim that the Roots which are lexicalized separately from *proc* cannot surface with additional DP complements precisely because the Roots which are spelled out separately from *proc* surface with nominal category. In the simple variant, the LI associated with the Root lexicalized *procP* (125).

- (124) Mikel-ek Jon bultza-tu du  
 Michael-ERG John.ABS push-TU have.3sgERG.3sgABS.PST  
 ‘Michael has pushed John’

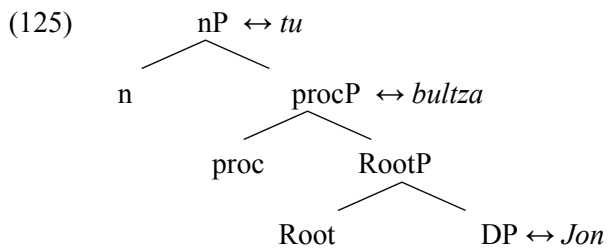

In contrast, in the complex *bultza egin*, the LI *bultza* only lexicalizes the Root, and *egin* lexicalizes *procP*. Thus, the Root surfaces with nominal category.

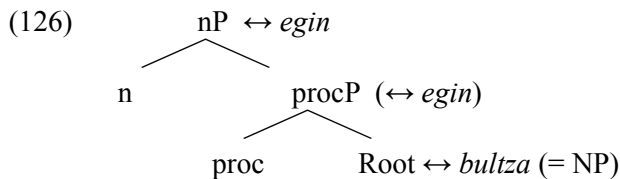

Since nominals are subject to case-requirements, the complementless restriction of complex predicates may be due, as some works on Basque (e.g. Laka 1993a, Fernández 1997) and Coon (2010) suggest, to reasons of case assignment. This case-requirement on Roots can be formulated by the following generalization:

(127) Generalization on Roots

Roots surface as nominals and need to be case-licensed if they are lexicalized separately from their respective subevent.<sup>64</sup>

A Root which is not lexicalized by a LI also lexicalizing its subeventive head surfaces as a nominal, and as such, it needs to be case-assigned. For instance, a Root

<sup>64</sup> This Generalization on the categorization and case-requirements of Roots is reminiscent of the classification of syntactic categories made in Mateu (2002) and Mateu & Rigau (2002) and of the Incorporation analysis of Baker (1988). See chapter 5, sec. 5.4.1 for a discussion on categorization and case-assignment.

in complement position of *proc*, will be realized as a nominal if it is not spelled out together (by the same LI) with *proc*.<sup>65</sup>

Apparently, an analysis of the complementless restriction of complex unergatives based on case-assignment has to face a problem, which involves the complements of some *egin* unergatives that are headed by the inessive *-n* and *-ka* (Etxepare 2003, Preminger 2012) (see 4.3.1 and 4.3.2). For instance, Preminger (2012) claims that, in those cases, the nominals (e.g. *dantza* etc.) are within adpositional phrases (so that *-n* and *-ka* are considered adpositions), and that, as a consequence, they cannot be targeted for agreement in Basque (Preminger 2009). Within my analysis, however, *-n* and *-ka* spell out a ClassP, responsible for the unbounded interpretation of the predicate, and are not considered adpositions. Thus, the presence of *-n* and *-ka* does not affect my analysis of the complementless restriction in terms of case-assignment. The Roots, which surface as nominals, are able to be targeted for case assignment even though they are within a ClassP.

#### 4.3.4. The lack of internal subjects

There is a further contrast that I would like to address before finishing this section. Complex unergative predicates are incompatible with internal subjects. The light predicate *egin* cannot be used in a predicate with a meaning of change of state and with an internal subject as the holder of that final state.

- (128) a. \*Ane ama egi-n da  
           Ane.ABS mother do-TU be.3sgABS  
           Intended: ‘Ane has become a mother’  
       b. \*Mahaia apur egi-n da  
           table.ABS bit do-TU be.3sgABS  
           Intended: ‘The table has broken’

In chapter 2, I posited that internal subjects originate in the specifier of a state subevent. This fact comes from the requirement of Property naming Roots to have a local subject (an inner subject, H&K 1993) to be predicated over. Remember, that, when a state subevent is selected by *proc*, it becomes a *res*.

---

<sup>65</sup> As we will see, this Generalization also applies for Roots in complement position of state subevents (see chapter 5, sec. 5.4.3). On the other hand, the implications of this Generalization for the categorization of the entire predicate are going to be considered in chapter 8.

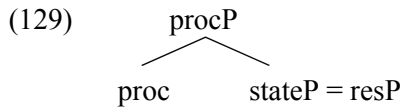

If *egin* lexicalizes *proc* and a given LI like *apur* lexicalizes a state subevent, it is not clear why *apur egin* cannot give rise to a change of state reading, and have a subject in the specifier of the state. Recall that the relation between *proc* and *res* is interpreted as implication, where the first subevent  $e_1$  (*proc*) causally implies  $e_2$  (*res*). Now, as I have explained in section 4.3.2, the relation between the subevent spelled out by *egin* and its complement is always interpreted as identification, this way, creating a homomorphic relation between the measure associated to the complement and the process denoted by *egin*.

The *-tu* suffix allows a structure where *proc* is related with its complement by either implication or identification, as it is extracted from the presence of unergative (e.g. *dantzatu* ‘to dance’) as well as unaccusative verbs (e.g. *amatu* ‘to become a mother’) formed by means of *-tu*. *Egin*, in contrast, is much more restrictive. Observe the following pairs:

- (130) a. Jon-ek txiza egin du  
 John-ERG piss do-TU have.3sgERG  
 ‘John has pissed’  
 b. Jon txiza-tu da<sup>66</sup>  
 John.ABS piss-TU be.3sgABS  
 ‘John has pissed himself’
- (131) a. Lehergailua-k leher egi-n du  
 bomb-ERG explode do-TU have.3sgERG  
 ‘The bomb has exploded’  
 b. Lehergailua leher-tu da  
 bomb.ABS explode-TU be.3sgABS  
 ‘The bomb has exploded’

In the *a* variants of these examples, *proc* is combined with its complement by means of identification, and this gives rise to durative/punctual readings where the subject is interpreted as an initiator. In the *b* variants, in contrast, *proc* and its complement are combined via implication, and this triggers a change of state reading where the subject is the holder of the final state.

<sup>66</sup> Note that in this example, *txizatu* does not have the meaning of ‘to become piss’, but ‘to become full of piss’. Thus, it seems that it is a locatum verb, even though the Root is not combined with an instrumental adposition.

In this sense, note that *-tu* only lexicalizes *procP* when there is a state subevent in its complement (e.g. *txizatu* and *lehertu* in (130b) and (131b)). Note that in those cases, there is an internal subject. In the rest of the contexts, the process subevent is either spelled out by an LI which also spells out the Root (e.g. *dantza* in *dantzatu* ‘to dance’) or it is spelled out by *egin*. Thus, it seems that the use of *egin* is in complementary distribution with the contexts where an internal argument (either an internal subject or a PATH DP object) is present and needs to be case-licensed. This distribution supports my analysis of the complementless restriction of *egin* unergatives as the impossibility to case-license two nominal arguments.

#### 4.3.5. A connection to the necessary external argument

It is also remarkable that *egin* complex predicates are always unergative: they have always an external argument. This phenomenon is related to Burzio’s Generalization (1986) and to the dual function of Voice. In *egin* unergatives there is a nominal (surface Root) which needs to be case-licensed. A case-licensor is then introduced in the syntax: Voice. A case licensing Voice also introduces an argument in its specifier, which, in this configuration, gets interpreted as the initiator. In this way, the necessary projection of the external subject may be connected to the necessity to case-license the nominal in complement position of *proc*.

#### 4.4. THE CASE OF THE “TARGET” OBJECT AND THE SIMPLE/COMPLEX DISTINCTION

In this section, I will address the aspectual contrasts reported in Etxepare (2003), also discussed in Fernández & Ortiz de Urbina (2010 2012), Odria & Berro (2011) and Pineda (2014), between the simple and complex forms of certain predicates and the dative/absolute marking of the target objects. I will suggest, following Fernández & Ortiz de Urbina (2012) and Pineda (2014), that the dative object is introduced as an applied object in a Low Applicative projection (Pylkkänen 2002/2008), and that the absolute object, in contrast, originates in the complement position of the Root (Harley 2005). Additionally, I will show that complex unergatives resist telicizing operations, such as the combination with delimiting allative modifiers, because their underlying subeventive structure is incompatible with a telic change of location configuration.

##### 4.4.1. Aspectual contrasts

Let us start analyzing first the contrast found between the complex and the simple forms of the predicates. In the sentences below, the predicates *–harrika egin* ‘to throw stones’/*harrikatu* ‘to stone’, *usna egin* ‘to smell at’/*usnatu* ‘to smell’ and *bultza egin* ‘to push’/*bultzatu* ‘to push’– take a “target” argument, which in the complex configuration is assigned dative case, and in the simple variant, in contrast, absolute case. The two forms have a slightly different aspectual interpretation. According to Etxepare (2003: 405), “whereas the complex predicate describes an attempted action without specifying whether the action affected the object, the simplex verb denotes an action that affects the object”.

- (132) a. Zoro batek oinezko bi-ri harri-ka egin zien  
 fool a-ERG pedestrian two-DAT stone-KA do-TU have.3sgERG.3plDAT.PST  
 ‘A fool threw stones at two pedestrians’  
 b. Zoro batek oinezko bi harri-ka-tu zituen  
 fool a-ERG pedestrian two.ABS stone-KA-TU have.3sgERG.3plABS.PST  
 ‘A fool stoned two pedestrians’
- (133) a. Zakurra-k hondakinei usna egi-n zien  
 dog-ERG garbage-DAT smell do-TU have.3sgERG.3plDAT.PST  
 ‘The dog smelled at the garbage’  
 b. Zakurra-k hondakinak usna-tu zituen  
 dog-ERG garbage.ABS smell-TU have.3sgERG.3plABS.PST  
 ‘The dog smelled (all) the garbage’

- (134) a. Jon-ek mahaiari (\*bazterr-era) bultza egi-n zion  
 John-ERG table-DAT (corner-ALL) push do-TU have.3sgERG.3sgDAT.PST  
 Intended: ‘John pushed at the table to the corner’  
 b. Jon-ek mahaia bazterr-era bultza-tu zuen  
 John-ERG table.ABS corner-ALL push-TU have.3sgERG.3sgABS.PST  
 ‘John pushed the table to the corner’ (Etxepare 2003: 405-406)

In (132a), the stones do not necessarily hit the walkers, while the predicate in (132b) implies that the walkers are actually affected by the stone-throwing. In (133b), the interpretation is that the dog makes a thorough examination of the garbage, whereas that of (133a) is not. Finally, in (134), the complex variant cannot be telicized by the presence of an allative modifier, while the simple one can perfectly combine with it.

In a close relation to that, there is a further aspectual contrast, this time, between simple predicates having the target object marked absolutive and those having it marked with dative case. Etxepare (2003: 407-419) suggests that these two configurations give rise to the same aspectual opposition found between simple and complex predicates.

- (135) a. Mikel-i (\*bazterr-era) bultza-tu dio  
 Michael-DAT (corner-ALL) push-TU have.3sgERG.3sgDAT  
 Intended: ‘He/ pushed Michael to the corner’  
 b. Mikel bazterr-era bultza-tu du (Etxepare 2003: 407)  
 Michael.ABS corner-ALL push-TU have.3sgERG.3sgABS  
 ‘He/she pushed Michael to the corner’  
 (136) a. Autobusera bultza-tu gaituzte  
 bus-ALL push-TU have.3plERG.1plABS  
 ‘They pushed us into the bus’  
 b. Autobuse-an/?autobus-era bultza-tu digute  
 bus-INE/ bus-ALL push-TU have.3plERG.1plDAT  
 Intended: ‘They pushed us into the bus’  
 c. ?Autobus-era bultza egi-n digute  
 bus-ALL push do-TU have.3plERG.1plDAT  
 Intended: ‘They pushed us into the bus’ (Etxepare 2003: 419)

The simple predicate *bultzatu* ‘to push’ admits an allative modifier adding the final location of the target object only when the target is marked absolutive. Furthermore, the allative modifier may have different interpretations in certain predicates depending on the case marking of the object.

- (137) a. Xabier      bulego-ra dei-tu      dute  
 Xabier.ABS office-ALL call-TU have.3plERG.3sgABS  
 ‘They called Xabier to the office’  
 b. Xabierr-i bulego-ra dei-tu      diote  
 Xabier-DAT office-ALL call-TU have.3plERG.3sgDAT  
 ‘They called Xabier to the office’

According to Etxepare (2003), (137a) is ambiguous between two readings: (i) Xabier is in his office and they called him there (i.e. on the phone), and (ii) Xabier is called from an office and ends there. The predicate in (137b), in contrast, has only the first reading. Etxepare notes that the simple form with the dative object is similar in this regard to the complex form of the predicate (*dei egin* ‘to call’). Finally, another predicate is also mentioned, *lagundu* ‘to help/to accompany’, which does not have a complex counterpart but which is also subject to a contrast depending on the case of the object.

- (138) a. Ezezagun batzu-ek      lagun-du gaituzte  
 unkown some-ERG help-TU have.3plERG.1plABS  
 ‘Unkown people helped us’  
 b. Ezezagun batzu-ek      lagun-du digute      (Etxepare 2003: 419)  
 unkown some-ERG help-TU have.3plERG.1plDAT  
 ‘Unkown people helped/accompanied us’

Etxepare claims that when the object is marked absolutive, the predicate means ‘to help’, while when marked dative, it can be translated either as ‘to help’ or ‘to accompany’.

#### 4.4.2. Some gathered data

Some data gathered by means of syntactic questionnaires conducted to several Basque speakers also show that there is a certain aspectual contrast between the simple and complex forms of some predicates when they take a further argument. In this section, I present four cases that, although they were not judged uniformly by all speakers, appeared to have a significant contrast. Speakers do not systematically claim that there is a semantic difference between the simple and the complex form of the predicates. Moreover, some of them only use the simple or the complex variant and do not have both forms in their language. However, the speakers who use both and find a difference between the two configurations usually associate an affected interpretation with the simple (transitive) variant, instead of with the complex (unergative) one.

The first opposition involves the use of the predicates *tiro egin* ‘to shoot’ and its simple counterpart *tirokatu* ‘to shoot’. These two predicates are similar to the previously presented *harrika egin/harrikatu* in that they can take a ‘target-like’ argument, marked absolutive in the simple variant and marked dative in the complex one. They are different in one aspect, though. *Tiro egin* lacks a morpheme appearing in the simple *tirokatu*: the classifier *-ka*.<sup>67</sup>

- (139) a. *Polizia-k gizonari tiro egi-n dio*  
 police-ERG man-DAT shoot do-TU have.3sgERG.3sgDAT  
 ‘The police shot at the man’  
 b. *Polizia-k gizona tiro-ka-tu du*  
 police-ERG man.ABS shoot-KA-TU have.3sgERG.3sgABS  
 ‘The police shot the man repeatedly’

Many speakers claimed that the simple transitive variant conveys that the direct object is shot more than once. This is explained by the presence of *-ka*, which, as I have claimed, lexicalizes a ClassP which triggers an iterative interpretation when combined with a semelfactive Event naming Root. However, this is not relevant for the current discussion. What is interesting is that, apart from that difference, some speakers also noted that in the transitive example the direct object *gizona* ‘the man’ is definitely hurt by the shooting, while in the unergative variant such an interpretation is not obligatory.

Our second example consists of two predicates denoting a mental activity: the complex form *amets egin/ametsetan egin* and the simple *amestu* ‘to dream’. The simple variant can take a direct object marked absolutive, which represents the ‘dreamed thing’. It can be, therefore, considered a hyponym argument, and thus, a PATH. An element with a similar interpretation can be introduced in the complex variant by means of an adpositional phrase: a sociative phrase or an instrumental phrase.

- (140) a. *Leku hor-taz/horr-ekin amets/amets-etan egi-n dut*  
 place that-INSTR/that-SOC dream/dream-INE do-TU have.1sgERG  
 ‘I have dream with that place’  
 b. *Leku bat ames-tu dut*  
 place a.ABS dream-TU have.1sgERG  
 ‘I have dreamed a place’

<sup>67</sup> Note that *tiro-tu* does not exist in Basque.



Some interviewed speakers noted that in the transitive example, consisting of the simple form and the absolutive marked object (140b), ‘the dreamed thing’ has to be an imagined, desired or not existing entity, created and projected in the mind of the speaker; a kind of outcome of the event of dreaming. In the unergative counterpart (140a), in contrast, the object introduced by the sociative or instrumental adposition can be perceived as real or existing, and brought to mind while sleeping.

The third and last opposition also involves the interpretation of a PATH, this time, in the predicates *salto egin* ‘to jump’ and *saltatu* ‘to jump’. The simple form can take an absolutive object with the meaning of a traversed path (e.g. a hole). The closest expression to this element can be conveyed in the complex variant through an ablative adposition.

- (141) a. Zuloa-ren gain-etik salto egin dut, [baina ez dut pasa]  
 hole-GEN above-ABL jump do-TU have.1sgERG [but I have not traversed it]  
 ‘I have jumped by above the hole, but I have not traversed it’  
 b. Zuloa saltatu dut, [#baina ez dut pasa]  
 hole.ABS jump-TU have.1sgERG [but I have not traversed it]  
 Intended: ‘I have jumped the hole, but I have not traversed it’

What is interesting is the the negation expressed in the second part of the sentences. In the transitive variant (141b), the sentence negating that the object has been traversed is not accepted. In contrast, in the unergative example, where the direct object is introduced as a Route Path (Pantcheva 2011), such a negation is accepted without problems.

These contrasts are obviously related to the position where the arguments are generated. In the last two cases, where the absolutive argument denotes a hyponym or a spatial delimiter of the event, the object has been introduced as a PATH in the complement of *proc*. In contrast, the adpositional phrases of the complex forms, the sociative/instrumental in *amets egin/ametsetan egin* ‘to dream’, and the ablative in *salto egin* ‘to jump’ are introduced as adjuncts; they describe the event but do not temporally/aspectually measure it. These elements cannot be inserted as PATHS because the position occupied by PATHS is precisely lexically spelled out by the Root complement of *egin*. In other words, in the complex variants, the Roots are the PATHS of *proc*, and as a consequence, they are the elements which measure out the event. In the simple forms, in contrast, the measures associated to *zuloa* ‘the hole’ and *leku hori* ‘that place’ are mapped to the temporal progress of the event. *Zuloa* ‘the hole’ is understood as a spatial delimiter, so that the event develops monotonically with the

subject traversing all the points of the path. If the event is finished, the path must have been traversed. On the other hand, since *amestu* involves creating images in the mind, when it is combined with a definite direct object like *leku hori* ‘that place’, the whole event behaves as a creation predicate, where each point of the object represents a point in the development of the creation event.

The case of *tiro egin/tirokatu* is different. In both cases, the object (absolute or dative marked) denotes the target of the event, but in the case of the absolute marked one, is additionally an undergoer. In the next lines, I will suggest that dative/absolute marked objects have different first-merge positions, and that this fact is indirectly related to the different interpretations obtained by some speakers. Nevertheless, since the dative/absolute case of the object is also dialectally distributed, the absolute vs. dative marking of objects cannot be always accounted for in aspectual terms.

#### 4.4.3. Dialectal variation: diminishing the aspectual factor

Some of the simple predicates addressed by Etxepare (2003) have been claimed to show dialectal object-case variation. For instance, Fernández & Ortiz de Urbina (2010 2012) point out, analyzing historical data from the *General Basque Dictionary* (Michelena & Sarasola 1989-2005) and synchronic data from the *Contemporary Reference Prose* (Sarasola et al. 2011) that the predicates *abisatu* ‘to warn’, *deitu* ‘to call’, *entzun* ‘to hear’, *eskertu* ‘to thank’, *lagundu* ‘to help’, *segitu* ‘to follow’, *bultzatu* ‘to push’, *itxaron* ‘to wait’ and *ukitu* ‘to touch’ display dialectal dative and absolute variation.<sup>68</sup> In this way, in south-western dialects the object is usually marked dative, whereas in north-eastern dialects of Basque, the object tends to be marked absolute.

- (142) a. Ane-k Mikel bultza-tu du *north-eastern dialects*  
 Ane-ERG Michael.ABS push-TU have.3sgERG.3sgABS  
 b. Ane-k Mikel-i bultza-tu dio *south-western dialects*  
 Ane-ERG Michael-DAT push-TU have.3sgERG.3sgDAT  
 ‘Ane has pushed Michael’

Fernández & Ortiz de Urbina (2012) argue that the aspectual difference put forward in Etxepare (2003) may not hold systematically, especially in western varieties where the object has to be marked dative. They argue that in western varieties the allative modifier is fine in combination with the verb *bultzatu* ‘to push’

<sup>68</sup> In some cases, both dative and absolute marking may even be found even within the same dialect or speaker (Fernández & Ortiz de Urbina 2012: 88).

and that both interpretations associated with *deitu* ‘to call’ are obtained when the object is marked dative. Furthermore, they suggest that even in the central dialect described by Etxepare (2003), the dative/absolutive variation may not be accounted for strictly on the grounds of an aspectual contrast. As a matter of fact, they argue that in the telic interpretation of the predicate *deitu* ‘to call’, where the allative modifier specifies the final location of the subject *Xabier* (143), the allative does not delimit the calling event, “but of some subevent whose syntactic correlate (if any) is unclear” (p.88).

- (143) *Xabier bulego-ra deitu dute*  
*Xabier.ABS office-ALL call-TU have.3pERG.3sgABS*  
 ‘They called Xabier to the office’

Additionally, Fernández & Ortiz de Urbina (2012) point out that the contrast found between the absolutive/dative variants of the predicate *lagundu* ‘help’ cannot be either considered to be aspectually related. Recall that the variant with the dative object was claimed to have two interpretations: ‘to help’ and ‘to accompany’, while the variant with the absolutive object, in contrast, only has the meaning of ‘to help’. Fernández & Ortiz de Urbina (2012: 88) suggest that “even if it were the case that the ‘accompany’ interpretation was found with delimited expressions (‘accompany home’), it would not fit the previous pattern, since this interpretation is precisely found with the dative marking only”.

All in all, it seems that the aspectual contrast, although very enlightening in some particular cases, cannot be generalized to all predicates or to all varieties, especially regarding simple variants.

#### 4.4.4. Introduction of absolutive and dative arguments

In this section, I will make a proposal concerning predicates which have simple and complex forms –like *bultza egin/bultzatu* ‘to push’, *harrika egin* ‘to throw stones’ / *harrikatu* ‘to stone’– and predicates which only occur in the simple form –*kritikatu* ‘to criticize’ and *ukitu* ‘to touch’– where the dative or absolutive argument is interpreted as the target. More specifically, I will suggest that datives and absolutive arguments in this kind of predicates are introduced in different syntactic positions, by different heads. As made by Fernández & Ortiz de Urbina (2012) and Pineda (2014), I propose that the dative argument generates in the specifier of a Low Applicative head

(Pylkkänen 2002/2008). The absolutive argument, in contrast, originates in the complement position of the Root, following the proposal made by Harley (2005).

Both Fernández & Ortiz de Urbina (2012) and Pineda (2014) argue that the dative argument of these predicates is an applied argument (see also Torrego 2010 for a similar analysis of parallel Spanish verbs). This analysis is easily applied to complex unergatives, where the Root is lexicalized separately from the *proc* head. Thus, in predicates like *bultza egin* ‘to push’, the complement position of Appl is occupied by the nominal (surface Root) *bultza*, *procP* is spelled out by the light predicate *egin* and the target object is assigned dative case by the Applicative head.<sup>69</sup>

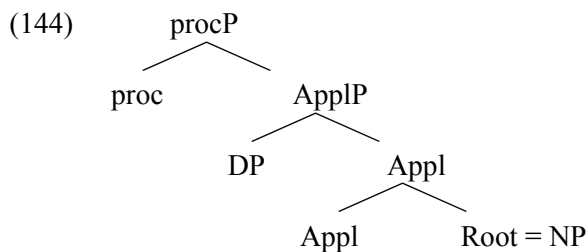

In complex unergatives, where the Root is embedded within ClassP (*harrika egin* ‘to throw stones’), the whole ClassP would be the complement of Appl.

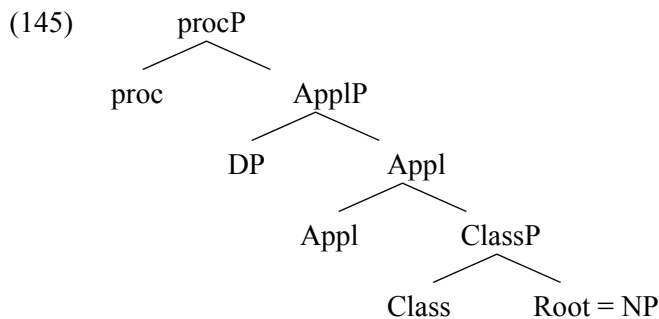

Similarly, the dative object of the simple forms *bultzatu*, *harrikatu* (and also of those which only have a simple form, e.g. *ukitu* ‘to touch’) are also first-merged in that position, in accordance with Fernández & Ortiz de Urbina (2012) and Pineda (2014). Both coincide in that the complement of the Applicative head would conflate into the verb and give rise to the apparent verbal realization. Pineda (2014) specifically proposes that the complement NP or Root is first conflated into the Appl head, and then into the verbal head. In my analysis, however, I have not assumed there is

<sup>69</sup> I am not going to make a proposal about the lexicalization of the Applicative head here, since it is not fundamental for the discussion and is out of the scope of this dissertation.

something like conflation taking place in this kind of denominal predicates: basing on the Superset Principle proposed within Nanosyntax (e.g. Starke 2009, Caha 2010), I have argued that a given LI like *bultza* can lexicalize phrasal nodes, and that it can, also, lexicalize a structure smaller than that stored in its lexical entry. Imagine that the lexical entry of *bultza* looks like this:

(146) *bultza* ↔ < /bultza/, procP, conceptual content >

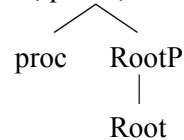

If this LI has to spell out the structure put forward in (145), it can do it in two possible ways: (i) *bultza* is inserted in *procP* and the head Appl and its specifier are somehow evacuated out of *procP*; or (ii) *bultza* spells out just the Root, and the *procP* node is spelled out by *-tu*. The latter would imply that the Root surfaces as a nominal and that it has to be case-licensed (according to my Generalization on Roots). The former option would involve the extraction of Appl and its specifier to the left of *procP*, so that the LI *bultza* can spell out the whole *procP*. This evacuation process would not be a typical case of Spell out driven movement (Caha 2010), like the ones I have proposed throughout the dissertation, since, in this particular context, the objects that have to be evacuated –Appl and DP– are in an intermediate position –between *proc* and the Root– and not in the tail of the structure. Since it is not fundamental for the discussion, I leave open which is the correct scenario.

In any case, in the simple variants, the dative argument, which superficially is the only internal argument, is really an indirect object.<sup>70</sup> This is in harmony with its dative case marking, the canonical case of indirect objects in Basque. Additionally, it also explains why these arguments cannot license secondary predication (Fernández & Ortiz de Urbina 2009 to appear), since low applied arguments do not accept secondary predication (see e.g. Pylkkänen 2002/2008, McFadden 2004).

As noted in Fernández & Ortiz de Urbina (2012), though, this analysis is more problematic for the other variant of these predicates where the object is absolutive, since it is expected that the Appl head always assigns dative to its specifier. My

<sup>70</sup> Of course, I am only proposing this analysis for this kind of alternating verbs, and not for the DOM (Differential Object Marking) found in other verbs like *ikusi* ‘to see’ and *eraman* ‘to carry’. See Fernández (2008), Fernández & Rezac (2010 to appear) and Odria (2014, forthcoming) to analyses on the latter kind of object alternation.

suggestion –as already presented in section 4.2.3– is that the objects which are marked absolutive are actually generated in a different syntactic position, as complement of the Root (Harley 2005).

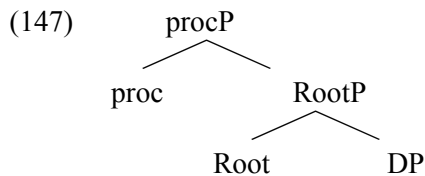

In the case of simple predicates consisting of the *-ka* morpheme, I suggest that ClassP is sandwiched between *procP* and RootP, as depicted in the tree.<sup>71</sup>

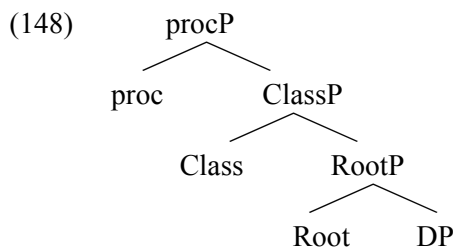

The different aspectual interpretations of absolutive and dative arguments may be associated with the different generating positions. The complement position of RootP may be the position of non-homomorphic UNDERGOER arguments, whereas the specifier of the Low ApplP corresponds to GOAL arguments (as suggested by Pylkkänen 2002/2008). However, the affected interpretation may also depend, to a great extent, on the combination between the syntactic configuration and the encyclopedic knowledge associated to the LIs in question. Recall that predicates like *kritikatu* ‘to criticize’ and *defendatu* ‘to defend’ also take this kind of absolutive objects (see section 2.3) and that those objects can be hardly interpreted as affected.

#### 4.4.5. About *push* and *call* in telic predicates

In this section, I want to analyze the two particular configurations where the *atelic* predicates *bultzatu* ‘to push’ and *deitu* ‘to call’ are combined with an allative modifier and are, as a consequence, telicized (Etxepare 2003).

<sup>71</sup> As I explained in section 4.2.1.2., in simple predicates built on the classifier *-ka*, the Root undergoes head movement to *proc*, and it is spelled out together with it. As a consequence, in a transitive structure like the one illustrated in (159), the DP would be the only nominal requiring case.

- (149) Jon-ek mahaia bazterr-era bultzatu du  
 John-ERG table.ABS corner-ALL push-TU have.3sgERG.3sgABS  
 ‘John pushed the table to the corner’
- (150) Xabier bulegora deitu dute  
 Xabier.ABS office-ALL call-TU have.3plERG.3sgABS  
 ‘They called Xabier to the office’

I will propose that, in predicates like (149) and (150), the LIs *bultzatu* and *deitu* are lexically inserted directly in *procP*, and not first in the Root position, as suggested for the unergative variants. This way, this approach builds on the “unergative adjunction” proposed in Mateu (2002) and Mateu and Rigau (2002), the “Manner incorporation” put forward in Harley (2005) and the conflation analysis made in Mateu (2012). Consider the sentences below:

- (151) The boy danced into the room  
 (152) John pushed the cart to New York

Mateu (2002) and Mateu and Rigau (2002) argue that in a sentence like (151), an unergative structure is subordinated into a main unaccusative structure. Recall Mateu’s (2002) relational syntax of argument structure. According to Mateu (2002: 29), argument structure types can be reduced to three:

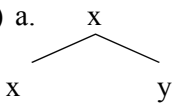
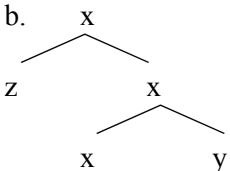
- (153) a.  b.  c. x

Each argument structure type is directly associated with its corresponding relational semantics:

- (154) a. The lexical head *x* in (153a) is to be associated to an eventive relation.  
 b. The lexical head *x* in (153b) is to be associated to a non-eventive/spatial relation.  
 c. The lexical head *x* in (153c) is to be associated to a non-relational element.

The event relation associated to *x* (153a) can be of two types, depending on whether there is an external argument in the specifier of FP above it. If there is an external argument, the eventive relation will be instantiated as a *source relation* [+R]– and the specifier in FP will be interpreted as the Originator. If there is no such an

external argument, then  $x$  will be instantiated as a *transitional relation* [+T]. Thus, an unergative predicate like *dance* has the following structure, consisting of both a Functional projection (FP) introducing the external argument, and a head  $x$  associated to an eventive *source* relation [+R].

(155) Unergative structure (Mateu 2002)

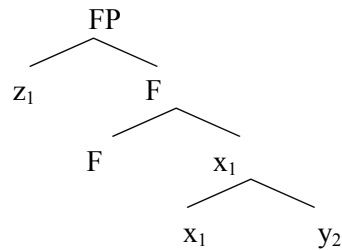

An unaccusative structure, in contrast, consists of both the head  $x_1$ , this time, associated to a transitional relation [+T], and a head  $x_2$ , associated to a non-eventive/spatial relation [+r].

(156) Unaccusative structure (Mateu 2002)

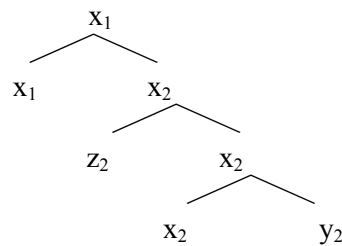

In a sentence like (151), *the boy danced into the room*, where an apparently “unergative” predicate combines with an adpositional phrase denoting the ending location, Mateu (2002) argues that the unergative and the unaccusative structure are fused into one. More specifically, he suggests that the unergative structure is adjoined to the transitional head of the unaccusative structure:



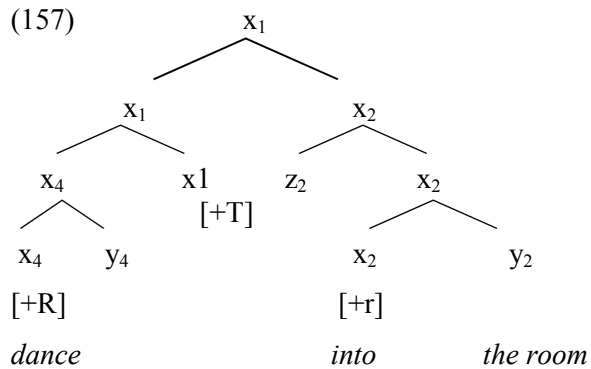

Thus, the unergative structure is merged into an originally transitional, unaccusative structure externally. According to Mateu (2002) and Mateu & Rigau (2002), the transitional head of the unaccusative structure would correspond to a predicate *go*, which in English has no phonological content. In order to be convergent in PF, the empty verb has to be conflated with another element with phonological properties, that is, the unergative *dance*. Thus, *dance* is introduced into a structure, which, put simply, does not belong to it. In more recent works, Mateu (2012) proposes that this adjunction or merging is a *conflation* process, following the characterization of conflation put forward in Haugen (2009). According to Haugen (2009), conflation and incorporation are two ways of forming denominal verbs. Incorporation is a case of head-movement, while conflation consists on external merge. Thus, incorporated Roots have their source in the argument structure of the verb, whereas conflated Roots do not (see also McIntre 2004, Zubizarreta & Oh 2007, Acedo-Matellán 2010).

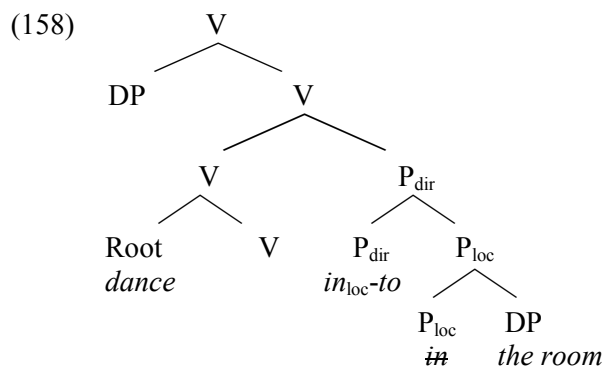

In Mateu's terms (2002), the Root *dance* has been introduced into the structure by means of external merge. It is not part of the argument structure of the predicate, which, in this case, is an unaccusative one.

Harley (2005) also argues along these lines when she analyzes the syntactic position of the Roots in sentences like (152), *John pushed the cart to New York*. She claims that, in this sentence, the Root cannot be in the sister to the *v* position, since, if it were there, it would be interpreted in terms of a homomorphic relation with the event (see section 4.2.1.1). According to her, *push* is an unbounded Event naming Root, and if it is in complement position of *v*, it gives rise to atelic predicates like the following:

(159) John pushed the cart

Thus, in a telic predicate like *push the cart to New York* (152), *push* cannot be in complement position. Instead, according to Harley (2005), the adpositional phrase denoting the final location is in the complement position of *v*, and that is the element triggering the telic reading of the entire predicate. Then, she proposes that the Root *push* is related to the verb by means of a process named “Manner incorporation”, which, according to her, is different from “the more usual head-movement mechanism which allows *v* to get its name via incorporation of a Root from lower in the argument structure” (p.61).

I claim that the telic predicates built up with the predicates *bultzatu* ‘to push’ and *deitu* ‘to call’ can be accounted for in similar terms. The allative modifiers lexicalize the PATH. The bounded structure of the PP is mapped to the temporal structure of the event, and as a consequence, the event becomes telic. This implies that the LIs *bultzata* and *dei* are directly inserted in *procP*, since there is not an available Root position in complement of *proc*. That position is already occupied by the allative PP.<sup>72</sup>

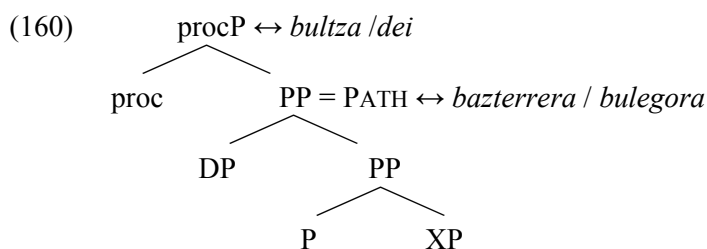

This telicizing mechanism is only available for predicates denoting motion towards a direction, because they can take a PATH object denoting a spatial path. In other words, the telicizing allative phase is only compatible with predicates like *bultzatu* ‘to

<sup>72</sup> The analysis of the insertion of the LIs directly in *procP* is reminiscent of the ‘insertion’ analysis made in Cinque (2004/2006), where lexical verbs are claimed to be inserted in functional projections in the context of restructuring.

push’, because *bultzatu* is compatible with a PATH denoting a change of location (see also Fábregas 2007 for a related analysis of Spanish manner of motion predicates). The internal argument, then, originates in the specifier of the PP, and is understood as traversing all the points of the spatial path until reaching the final one. See also Fernández & Ortiz de Urbina (2012: 94-95) which consider a similar analysis.

The fact that the allative modifiers are in the complement position of *proc* is precisely the reason for not having a complex unergative in this kind of telic configurations.

- (161) Jon-ek mahaia-ri (\*bazterr-era) bultza egi-n dio  
 John-ERG table-DAT (corner-ALL push do-TU have.3sgERG.3sgDAT  
 Intended: ‘John pushed the table to the corner’

In complex unergatives, the Root is lexicalized in complement position of *proc* and is, as a consequence, the PATH of *proc* (see section 4.3.2). In telic configurations like (160), the complement position of *proc* is occupied by the PP. Thus, having a Root as PATH is incompatible with having a PP as PATH, since only one element can occupy the complement position of *proc* and be a PATH object. Therefore, in this case, the locus of the aspectual contrast found between simple and complex predicates may not be the absolutive vs. dative marking of the object, but the subeventive structure underlying each predicate.

#### 4.5. CONCLUSION

In this chapter, I have analyzed the subeventive decomposition and lexicalization of unergative and non-causative transitive predicates. I have claimed that these predicates consist of a process subevent, and that, contrary to unaccusative and causative transitive predicates analyzed in chapter 3, do not involve the projection of a state subevent, but of a Rheme of process.

Basing on the distinction introduced in chapter 2 between implication and identification, in this chapter, I have studied several different cases where *proc* is identified with its Rheme. I have claimed that in the intransitive uses of morphologically simple predicates like *saltatu* ‘to jump’ and also in complex unergative predicates like *elurra egin* ‘to snow’, the Root, which occupies the position of complement of *proc*, performs the role of a Rheme of process, measuring and constraining the aspectual interpretation of the entire event. This is possible by the fact that Roots are associated to measures, where measures are defined as points in a path or a location. Depending on the properties of the measure ([±incremental], [±lower bound], [±upper bound]) the mapping from the points of the measure to the subintervals introduced by *proc* yields different types of aspectual predicates. In this way, I have been able to explain the aspectual contrasts found among morphologically simple predicates, as well as among complex unergative predicates.

In this chapter, I have also addressed the categorization and case-requirements of Roots. From the study of complex unergative predicates, I have concluded that if a Root is spelled out separately from the functional projection encoding a subevent, it surfaces as a nominal and has to be case-licensed. In morphologically simple predicates, the LIs associated to those Roots are inserted in the *procP* node, and thus, the Root and *proc* are spelled out with a single LI. In complex predicates, on the other hand, the LI associated with the Root is only inserted in the position of the Root –that is to say, in the complement position of *proc*– and *procP* is lexicalized by the light predicate *egin*. These different lexicalization patterns have consequences for categorization and case-assignment, as formulated in the Generalization on Roots:

(162) Generalization on Roots

Roots surface as nominals and need to be case-licensed if they are lexicalized separately from their respective subevent.

Since the Roots in complex predicates are lexicalized apart from the process subevent, they surface as nominals and, consequently, have to be case-licensed. Agreeing with previous proposals like Bobaljik (1993), Laka (1993a) and Fernández (1997), I have claimed that this is actually the reason for complex unergatives not having a DP direct object. The Root has to be case-licensed, and thus, another DP complement cannot receive case. On the other hand, in simple predicates, the LI associated with the predicate is lexicalized in the respective subeventive node, so that an overt DP can be case-licensed.

Finally, as analyzed in section 4.4, the fact that in complex unergative predicates, the Root is lexicalized in complement position of *proc* also explains why complex unergatives resist telicization by an allative modifier. Allative modifiers of directional predicates like *bultzatu* ‘to push’ and *deitu* ‘to call’ are in the position of complement of *proc*, and are, thus, Rhemes of process (in this case PATHS). They can occur with morphologically simple predicates, because, in simple predicates, the LI associated with the Root (e.g. *bultza*) is inserted in *procP* and the element in its complement position can be the allative phrase. In *egin* unergatives, in contrast, the LI associated with the Root is inserted in the complement position of *proc* and not higher, since *procP* is lexicalized by *egin*. *Egin* unergatives are thus incompatible with delimiting allative phrases, simply because, in the structure that *bultza egin* lexicalizes, the complement position of *proc* is filled by the Root.

## **5. Adpositions, events and the verbal category**



## 5.1. INTRODUCTION

In this chapter, I will argue that syntactic heads like V and v are not present in Basque analytic predicates. Firstly, I will focus on location predicates (Hale & Keyser 1993) which in Basque are built on allative phrases (e.g. *etxe-ra-tu* ‘to go/take sb home’, *ohere-ra-tu* ‘to go/take sb to bed’) (sec. 5.2). I will show that Basque location predicates can only be built on GoalPs (Pantcheva 2011), and not on PlacePs, SourcePs or ScalePs. Basing on this restriction, I will suggest that location predicates cannot be argued to consist of a silent V to which an adposition has been incorporated. Instead, I will argue that the subeventive structure (Ramchand 2004 2008a) and the adpositional decomposition structure (Svenonius 2006 2008, Pantcheva 2001) are isomorphic and that this makes possible to have LIs like *-ra-* (the allative) inserted in the *proc*P node. This fact suggests that the *proc* cannot syntactically represent a V head, since it can be lexicalized by LIs which usually spell out adpositions.

Secondly, I will show that *-tu* headed predicates share some distributional properties with nominals. The nominal distribution of *-tu* predicates in several linguistic contexts points out that *-tu* cannot be considered a verbalizer in the sense of Marantz (1997). Thus, neither V nor v seem to be present in Basque analytic predicates.

Finally, in this chapter, I am also going to consider the implication of the Generalization of Roots put forward in chapter 4 for the theory of categorization and its relation with the nominal category of the predicate. I will show that the Generalization of Roots, which in chapter 4 was proposed in the context of the process subevent, predicts correctly when a Root will surface with nominal category also in state subevents.

The outline of the chapter is the following. Firstly, I will analyze location predicates (5.2), concluding that a silent V cannot be argued to be present in this kind of predicate. Then, I will deal with the nominal distribution of *-tu* headed predicates (5.3). Additionally, I will consider some implications of the Generalization on Roots and of the nominal category of predicates (5.4), and finally, I will present the main conclusion (5.5).



## 5.2. THE CASE OF LOCATION PREDICATES

### 5.2.1. Possible location predicates<sup>73</sup>

Location predicates formed by the allative morpheme (-ra)<sup>74</sup> are very productive in Basque. Below (1) there is a list of some of these predicates taken from the corpus *Contemporary Reference Prose* (Sarasola et al. 2011) –using the *Corsintax* browser (Landa 2008) and the *Dictionary of Contemporary Basque* (Sarasola in progress)<sup>75</sup> and from Mujika (2008). In (2), there are examples for the verb *etxeratu* ‘go home’ and *argitaratu* ‘publish, come to the light’.

#### (1) LIST OF SOME LOCATION PREDICATES

|                   |                                                   |             |                          |
|-------------------|---------------------------------------------------|-------------|--------------------------|
| aberriratu        | ‘repatriate, return home’                         | <b>from</b> | aberri ‘homeland’        |
| adineratu         | ‘come to an age’                                  |             | adin ‘age’               |
| argitaratu        | ‘publish, lit. bring to the light’                |             | argi ‘light’             |
| ahalbide(ra)tu    | ‘make possible’                                   |             | ahalbide ‘possibility’   |
| aurreratu         | ‘go/bring forward, advance’                       |             | aurre ‘front’            |
| aitzinatu         | ‘to go /bring forward’                            |             | aitzin ‘front’           |
| alboratu          | ‘to approach, go/move aside’                      |             | albo ‘side’              |
| aldaratu/alderatu | ‘to approach, compare’                            |             | alde ‘side, part’        |
| araupetu          | ‘to regulate’                                     |             | arau ‘rule’, pe ‘under’  |
| atzeratu          | ‘to put/set back, delay, postpone’                |             | atze ‘back’              |
| atzerriratu       | ‘to emigrate, exile’                              |             | atzerri ‘abroad’         |
| aurpegiratu       | ‘to reproach, blame’                              |             | aurpegi ‘face’           |
| auzipe(ra)tu      | ‘to prosecute’                                    |             | auzi ‘trial’, pe ‘under’ |
| azaleratu         | ‘to emerge, surface’                              |             | azal ‘skin, surface’     |
| azpiratu          | ‘to subdue, defeat’                               |             | azpi ‘downside’          |
| barneratu         | ‘to enter, go/put sth in/into’                    |             | barne ‘inside’           |
| barruratu         | ‘to enter, go/put sth in/into’                    |             | barru ‘inside’           |
| basoratu          | ‘to go/bring to the woods’                        |             | baso ‘woods’             |
| bateratu          | ‘to unite, unify’                                 |             | bat ‘one’                |
| bazterr(era)tu    | ‘to take/leave sb/sth aside, to walk to the side’ |             |                          |
| begietaratu       | ‘to come/bring to the eyes’                       |             | begi ‘eye’               |
| belarriataratu    | ‘to listen, realize’                              |             | belarri ‘ear’            |

<sup>73</sup> Parts of the study presented in this section have been previously published in Berro (2015 in press).

<sup>74</sup> The allative morpheme *-ra* occurs accompanied by other morphemes when the Ground is plural (*-e-ta-ra*), indefinite (*-ta-ra*), animate singular (*-ren-gan-a*) or animate plural (*-en-gan-a*). This scheme also applies for the inessive, the ablative and the approximative adpositions. In this study about location predicates, I am only going to focus on the allative *ra*, the inessive *-n*, the ablative *-tik* and the approximative *-rantz*, without addressing the rest of the morphemes.

<sup>75</sup> The *Dictionary of Contemporary Basque* (Sarasola in progress) is based on the corpus *Contemporary Reference Prose* and aims at reflecting Basque as it is used today.

|                |                                       |        |                           |
|----------------|---------------------------------------|--------|---------------------------|
| bereganatu     | 'to appropriate, seize'               | bere   | 'his/her/hers'            |
| bururatu       | 'to occur to sb, think of sth'        | buru   | 'head'                    |
| elizaratu      | 'to go/bring to the church'           | eliz   | 'church'                  |
| elkarganatu    | 'to meet, come together'              | elkar  | 'each other'              |
| eskuratu       | 'to get, achieve'                     | esku   | 'hand'                    |
| etxeratu       | 'to go/bring home'                    | etxe   | 'house'                   |
| giltzape(ra)tu | 'to shut sb/sth up, to imprison'      | giltza | 'key' pe 'under'          |
| gogoratu       | 'to remember'                         | gogo   | 'mind'                    |
| honatu         | 'to come/bring here'                  | hona   | 'here-ALL'                |
| horratu        | 'to go/bring there'                   | horra  | 'there-ALL'               |
| itsasoratu     | 'to put out to sea, flow into'        | itsaso | 'sea'                     |
| kaleratu       | 'to go out, expel, publish'           | kale   | 'street'                  |
| konturatu      | 'to realize, notice'                  | kontu  | 'care'                    |
| lehorreratu    | 'to go/put ashore'                    | lehor  | 'land'                    |
| mahaigaineratu | 'to put on the table'                 | mahai  | 'table', gain 'on top of' |
| menderatu      | 'to subdue, defeat'                   | mende  | 'under the control'       |
| munduratu      | 'to be born, come/bring to the world' | mundu  | 'world'                   |
| noratu         | 'to go/bring somewhere'               | nora   | 'where-ALL'               |
| oheratu        | 'to go/put to bed'                    | ohe    | 'bed'                     |
| zeruratu       | 'to take off, go/bring to heaven'     | zeru   | 'sky, heaven'             |

- (2) a. Neskak goiz etxe-ra-tu dira  
 girls.ABS early home-ALL-TU be.3plABS  
 'The girls have gone home early'
- b. Idazle honek beste liburu bat argi-tara-tu du  
 writer this-ERG other book a.ABS light-ALL-TU have.3sgERG.3sgABS  
 'This writer has published another book'

These predicates have a very transparent internal structure. Most of them are formed from the allative adposition *-ra* plus its complement ground, such as *aberri-*ra*-tu* (homeland-ALL-TU) 'to repatriate' and *argi-tara-tu* (light-ALL-TU) 'to publish'. Some of them also include the Region or Axial Part of the complement, as in *mahaigain-*era*-tu* (table-top-ALL-TU) 'to put on the table' and *auzi-pe-*ra*-tu* (trial-under-ALL-TU) 'to prosecute'. There are some predicates which can optionally drop the allative morpheme, as in *auzi-pe-(*ra*)-tu* 'to prosecute', *giltza-pe-(*ra*)-tu*<sup>76</sup> (key-under-(ALL)-TU) 'to shut sb/sth up, to imprison' and *bazterr-(*era*)-tu* 'to take sb/sth to the

<sup>76</sup> In the case of *giltza-pe-(*ra*)-tu*, the *Dictionary of the Royal Academy of Basque* (2012) only lists the predicate without the allative morpheme, as *giltza-pe-tu*. Nevertheless, both versions are accepted and used by Basque speakers, as reflected in the corpus *Contemporary Reference Prose*.

side/ to leave sb/sth aside’. Finally, some predicates do not take the allative morpheme and just consist of the Axial Part, like *arau-pe-tu* (rule-under-TU) ‘to regulate’.

Outside locative predicates, the allative adposition is used in Goal complements, usually in combination with predicates of inherent motion predicates, as can be seen in (3) or (4):

- (3) *Mundu-ra atera nintzen orduan* [A.Gorostizu, *Berria* 2004-12-15]  
 world-ALL go-out be.1sgABS.PST then  
 ‘Then, I came out to the world’
- (4) [*Handik bost minutura*], *berriro itzuli zen etxe-aurr-era*  
 [In five minutes from then], again go-back-TU be.3sgABS.PST house-front-ALL  
 ‘In five minutes from then, he/she returned again to the front of the house’  
 [I.Mendiguren (J.K.Rowling), 2001: 60]

In (3), the allative morpheme appears attached to the Ground complement *mundu* ‘world’. In (4), it occurs following the Axial Part *aurre* ‘front’, which takes *etxe* ‘house’ as its complement. It seems clear that the predicates listed in (1) are structured on PPs similar to those in (3) and (4). As I mentioned in chapter 1, H&K (1993 2002 2005) (and also Oyharçabal 2003) argue in favor of this analysis. They claim that location predicates of the *shelve* type (5) are syntactically built on a PP.

- (5) I shelved the books

In this section, I will show that location predicates are related to PPs, in accordance with H&K and Oyharçabal (2003). Nevertheless, this relation is much more direct than previously thought. I will claim that there is not a silent V selecting for a PP, but instead, I will propose that the allative *ra* directly spells out procP. This analysis of *ra* is supported by two facts: (i) the formation of location predicates in Basque is restricted (they cannot be built on any type of PP); and (ii) the head represented by *ra* and the subevent head *proc* are structurally and topologically equivalent.

In order to understand better the nature and limits of location predicates, a decompositional analysis of adpositions is needed. To begin with, I suggest that in location predicates, at least a Path head and a Place head are projected.<sup>77</sup> Jackendoff (1983) proposes that the conceptual structure of Path consists of two ingredients: Path and Place. van Riemsdijk and Huijbregts (2002) and Svenonius (2006 2008) have shown that these elements project a syntactic head. The Basque allative would be a *portmanteau* morpheme lexicalizing both these heads (see Etxepare & Oyharçabal

<sup>77</sup> Note that Path belongs to a head of the adpositional phrase, and that it is different from the PATH objects that I have analyzed in chapter 3 and 4.

2012, Etxepare 2013). For instance, many location predicates can be paraphrased with change of position predicates combined with a PP headed by the inessive morpheme *-n*. For example, a possible way to paraphrase the predicate *aurre-ra-tu* ‘go/take to the front’ (6a) is using *aurre-an jarri* ‘lit. put in the front’ (6b).<sup>78</sup>

- (6) a. *Irakaslea-k neskak aurre-ra-tu ditu*  
 teacher-ERG girls.ABS front-ALL-TU have. 3sgERG.3plABS  
 ‘The teacher has put the girls in the front’  
 b. *Irakasleak neskak aurre-an jarri ditu*  
 teacher-ERG girls.ABS front-INE put-TU have. 3sgERG.3plABS  
 ‘The teacher has put the girls in the front’

The inessive is the morpheme lexicalizing Place. Therefore, Place is lexicalized by means of the PP in (6b) and Path is realized in the verb *jarri* ‘to put’. The location predicate *aurre-ra-tu* (6a), on the other hand, lexicalizes both Path and Place, as shown in (7).

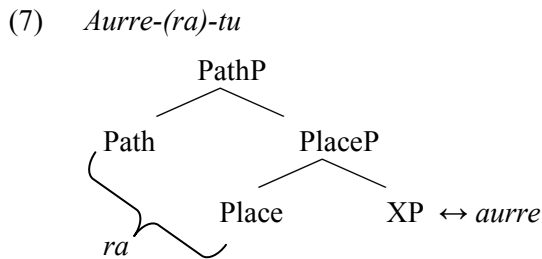

Following the lexicalization procedure proposed in chapter 1 and 2, I suggest that the allative has the following lexical entry, and that its insertion in the phrasal node PathP triggers the cyclic movement of XP, first to left of PlaceP and then to the left of PathP.

- (8) *-ra-* ↔ < /ra/, PathP >
- 
- ```

  graph TD
    PathP --> Path
    PathP --> PlaceP
    PlaceP --> Place
  
```

For ease of exposition, I will omit all lexical evacuation operations in the analysis, since they are not necessary for the current discussion.

<sup>78</sup> The sentence in (6a) is ambiguous, so that there is more than one way to paraphrase such example. The two possible readings of (6a) are: (i) the teacher has taken the girls to the front/put the girls in the front, the one in (6b); and (ii) the teacher has gone past the girls/has gone to the front of the girls. In the second possible interpretation, the DP *neskak* ‘the girls’ does not correspond to the Figure of the adposition, but to the Ground.

In certain predicates, an additional morpheme occurs between the Ground complement and the allative adposition, as in *giltza-pe-(ra)-tu* ‘to shut sb/sh up’, *auzi-pe-(ra)-tu* ‘to prosecute’, *mahai-gain-era-tu* ‘to put sth on the table’. These elements have been called postpositions or locational nouns (Euskaltzaindia 1991[1985], de Rijk 2008, Eguzkitza 1997, Hualde 2002, Etxepare 2013). Following Etxepare (2013), I consider that when these elements are projective, they actually represent the syntactic head Axial Part. According to Svenonius (2006), Place further embeds Axial Part and KP. In the case of Basque, the ground can combine with the Axial Part in two ways (Etxepare 2013): (i) receiving genitive case (9a); or (ii) forming a compound with the Axial Part (9b).<sup>79</sup>

- (9) a. Etxea-ren aurre-an  
house-GEN front-INE  
b. Etxe-aurre-an (Etxepare 2013: 19)  
house-front-INE  
‘In front of the house’

As can be seen, in location predicates, it is combined by means of compounding. Thus, a given location verb like *auzi-pe-(ra)-tu* ‘lit. to put under trial’ consists of the allative (lexicalizing both Path and Place), the Axial Part *-pe-* ‘under’ and its ground complement *auzi* ‘trial’.<sup>80</sup>

- (10) *Auzi-pe-(ra)-tu*

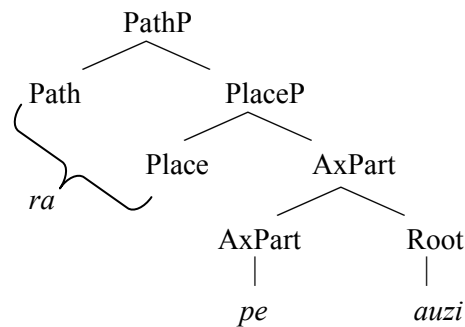

<sup>79</sup> See Etxepare (2013) for an analysis of the syntactic and interpretative differences between both forms of combining the ground with the Axial Part.

<sup>80</sup> It is interesting to note that the Axial Part head *-pe-* can occur in some predicates without the allative morpheme (*auzi-pe-tu* ‘to prosecute’, *arau-pe-tu* ‘to regulate’, *giltza-pe-tu* ‘lock’). This property is not shared by other Axial Part heads of Basque. As a matter of fact, the Axial Part *-gain-* ‘on top of’ cannot occur on its own, since with *-gain-* the allative is obligatory: *mahai-gain-era-tu* ‘put on the table’ but *\*mahai-gain-du*. Like with *-gain-*, the same happens with the Axial Part *aurre* ‘front’ and *atze* ‘back’: *aurre-ra-tu* ‘to move forward’, *atze-ra-tu* ‘to move/set back’, but *\*aurre-tu*, *\*atze-tu*.

### 5.2.2. Impossible location predicates

In the previous section I have analyzed the structure of possible location predicates in Basque. I have concluded that they consist of a PP containing at least Path, Ground and Axial Part. In this section, I will analyze impossible location predicates, in order to understand better their limits. I will show that Basque location predicates cannot be built on a bare PlaceP, a SourceP or a ScaleP.

Firstly, I will show the impossibility of a bare PlaceP to become a location predicate. Basque location predicates cannot consist of a PP complement realized with the inessive morpheme *-n* (Mujika 2008):

#### (11) IMPOSSIBLE LOCATION PREDICATES WITH THE INESSIVE MORPHEME

*etxe-an-du	but	etxe-ra-tu	‘to go/to take home’
*ohe-an-du		ohe-ra-tu	‘to go/to take to bed’
*esku-an-du		esku-ra-tu	‘to take, to get, lit. to come to hand’
*esku-etan-du		esku-etara-tu	‘to acquire, to give, lit. to come to the hands’
*bere-gan-du		bere-gana-tu	‘to appropriate, lit. to come to oneself’
*gogo-an-du		gogo-ra-tu	‘to remember, lit. to come to mind’

A possible explanation could be that in a predicate like *\*etxe-an-tu* not all the features present in the syntactic tree are lexicalized. This is actually ruled by the principle of *Exhaustive Lexicalization* (Fábregas 2007, Ramchand 2008b, Starke 2009, Caha 2010, Pantcheva 2011) presented in Introduction and repeated below.

#### (12) Exhaustive Lexicalization (Fábregas 2007: 167)

Every syntactic feature must be lexicalized.

The structure of location predicates involves a Path head and this must be realized lexically, due to Exhaustive Lexicalization. The inessive morpheme of Basque only lexicalizes Place, so that, a location predicate lexicalized with just the inessive morpheme plus its complement (11) would not be grammatical, since Path gets no lexical content in such a structure.

Recall however that in chapter 1, I proposed that the verbalizing morpheme *-tu*, which spells out both *n* and process, can be attached to LIs lexicalizing a spatial state, like the deadverbial predicates of change of location (e.g. *urrun-du* ‘to move away, lit far-TU).

For instance, Mitxelena (1977[2011]: 278-279) lists some location predicates consisting of the inessive adposition:

(13) LOCATION PREDICATES WITH THE INESSIVE MORPHEME

gain-ean-du	‘to put sth on top of X or to move to the top of X’	In Leizarraga (an author of the 16 <sup>th</sup> century)
aitzi-n-du	‘to advance, lit. to take sth / move to the front’	In Axular (an author of the 17 <sup>th</sup> century), who also uses the parallel verb built on the allative ( <i>aitzi-n-a-tu</i> )
atze-n-du	‘to put/set back or to move back’	High-Navarres / Guipuzcoan
oste-n-du	‘to hide, lit. put sth back or move to the back’	Biscayan
aurki-n-du	‘find’, lit. put sth in the front part’	

I consider that these instances of location predicates built on the inessive phrase represent an isolated phenomenon, at least in modern Basque. The predicates *gaineandu* and *aurkindu* are not attested nowadays. Instead, the predicates derived from the allative *gaineratu* and the predicate derived from the adverb –without the inessive– *aurkitu* are used. As for *atzen* and *aitzindu*, their presence in the written corpora (specifically in *Contemporary Reference Prose* and *Contemporary Dynamic Prose*)<sup>81</sup> is very poor, moreover, in contrast with their allative derived counterparts *atzeratu* and *aitzinatu*.

Nevertheless, the possibility of *-tu* selecting bare PlacePs must not be discarded. Note that the Axial Part *-pe-* ‘under’ can occur without the allative adposition in location verbs: *giltza-pe-tu* ‘to shut sb up’, *auzi-pe-tu* ‘to prosecute’, *arau-pe-tu* ‘to regulate’. I consider that in those cases, the dynamic part of the structure is lexicalized by *-tu*, as it happens in other derived predicates of change of state or location (see chapter 3). Thus, in those location verbs where the allative adposition (*ra*) is not present, I conclude that the “dynamicity” is similarly present in the structure, the only difference being that it is lexicalized by means of another LI.<sup>82</sup>

Until now, I have shown that PathP is the minimal structural layer that has to be present in the PPs of location predicates. Now, I will show that it is a specific type of

<sup>81</sup> The corpus *Contemporary Dynamic Prose* (Sarasola, Salaburu & Landa 2009) is a corpus which gathers Basque written texts in the last four years and which is updated every year.

<sup>82</sup> Nevertheless, adopting this view, I would have to face the problem of why *-tu* can lexicalize the dynamic portion of the structure in *giltza-pe-tu* ‘lock’ and not in *\*etxe-an-tu* ‘go home’ consisting of the inessive. It may depend on the categorial status of the complement of *-tu*. I leave this issue for further research.

Path, a GoalP, which is the minimal and also the maximal layer that these location predicates can have. Location predicates cannot be built on ablative PPs or approximative PPs. Location predicates which take the ablative morpheme *-tik* (Mujika 2008) or the approximative allative *-rantz* do not exist:

## (14) IMPOSSIBLE LOCATION PREDICATES WITH THE ABLATIVE MORPHEME

*etxe-tik-tu	'to come/take from home'
*itsaso-tik-tu	'to come from the sea'
*ohe-tik-tu	'to come/take from the bed'
*esku-tik-tu	'to take from the hand'
*esku-etatik-tu	'to take from the hands'
*bere-gandik-tu	'to take from oneself'
*gogo-tik-tu	'to come from mind'

## (15) IMPOSSIBLE LOCATION PREDICATES WITH THE APPROXIMATIVE ALLATIVE MORPHEME

*etxe-rantz-tu	'to go/take sth towards home'
*itsaso-rantz-tu	'to go/take sth towards the sea'
*ohe-rantz-tu	'to go/take sb/sth towards the bed'
*esku-rantz-tu	'to take sth towards the hand'
*esku-etarantz-tu	'to take sth towards the hands'
*bere-ganantz-tu	'to take sth towards oneself'
*gogo-rantz-tu	'to come towards mind'

Both the ablative and the approximative PPs can be considered Path heads. If PathP is the minimal phrase that has to be present in location verbs, then, why is it that Source and approximative PPs cannot be part of them? This contrast can be related to what is usually referred to as the Goal-Source asymmetry. It has been noted in the literature that Goals and Sources (as well as Routes) are not symmetrically organized cross-linguistically. Sources are usually more marked than Goals (Ikegami 1982, Pantcheva 2011). For example, the unmarked expressions *here* and *there* can have a Goal meaning, while in order to denote Source, they need to be accompanied by *from*; *from here*, *from there* (Pantcheva 2011: 73). On the other hand, with certain predicates Sources are only available if Goal expressions are also present (Levin 1993: 177):

- (16) a. The witch turned him from a prince into a frog  
 b. The witch turned him into a frog  
 c. \*The witch turned him from a prince



Similarly, as Gehrke (2008: 229) notes, in a sentence like ‘the frog turned green’, which lacks the overt expression of the preposition, ‘green’ can only have a Goal meaning, conveying the ending color of the frog, and not the starting one. The fact that location predicates can only be built on Goal Paths and not on Source or Scale Paths is another example of this asymmetry. My suggestion is that this morphosyntactic contrast can be accounted for by positing different semantic and syntactic structures for the different types of paths, as done in Pantcheva (2011).

Pantcheva (2011) shows that Path can be decomposed into a more grained structure: RouteP, SourceP and GoalP.

(17) DECOMPOSITION OF PATHP

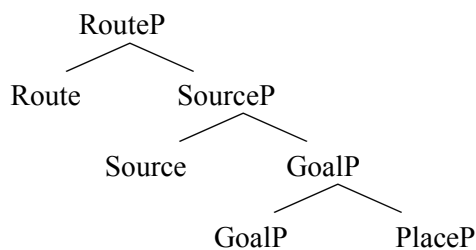

According to her, each type of Path corresponds to a unique syntactic structure:

(18) PATH TYPES

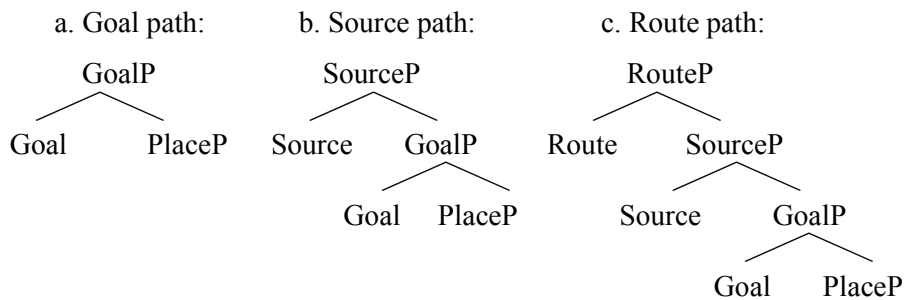

Crucially, Pantcheva considers Source Paths more complex than Goals. This greater complexity can explain the Goal bias (Lakusta 2005, Lakusta & Landau 2005, Gehrke 2008) attested also in the psycholinguistic domain, which points out that there is a natural bias for encoding Goals over Sources in the representation of events.

Following Etxepare (2013), I claim that the ablative morpheme of Basque lexicalizes three features, namely, [Source], [Path] and [Place]. I suggest that its lexical entry corresponds to (19). Since *\*etxe-tik-tu* ‘to go/take sb from home’ is an

impossible location predicate, but *etxe-ra-tu* ‘to go/take sb home’ is totally possible, I argue that the GoalP projection delimits the domain of possible location verbs.

(19) *-tik* ↔ < /tik/, SourceP >

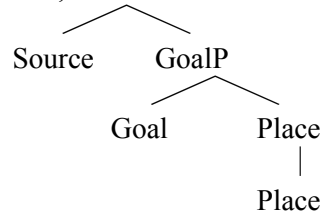

According to Pantcheva (2011), non-transitional Paths like the approximative PP are formed when a head Scale selects any transitional path. The approximative would be the result of the selection of GoalP by Scale (20a). How this structure is lexicalized in Basque is illustrated in (20b).

(20) APPROXIMATIVE PATHS

a. Approximative Path

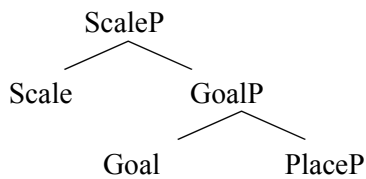

b. Approximative Path in Basque

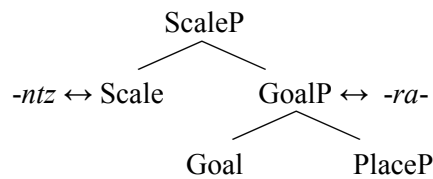

Again, the ungrammaticality of location verbs consisting of the approximative allative morpheme indicates that GoalP delimits the domain of possible location predicates.

(21) DECOMPOSED STRUCTURE OF PPS

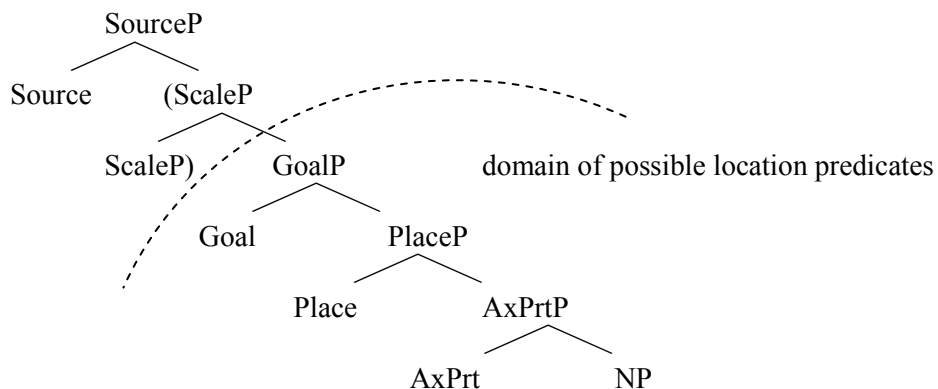

More complex structure that can be built on top of GoalP, like SourceP or ScaleP, cannot be part of location verbs.

### 5.2.3. Concerning lexicalization

In this section, I will briefly recapitulate the lexicalization approaches adopted by H&K (1993 2002 2005). In their 1993 paper, H&K argue that in location predicates, the inner V, an empty head, takes a PP as a complement, which has an empty P head. The example in (22) represents the l-syntax structure of the predicate *shelve*.

(22) L-SYNTAX STRUCTURE OF *SHELVE*; INCORPORATION ANALYSIS

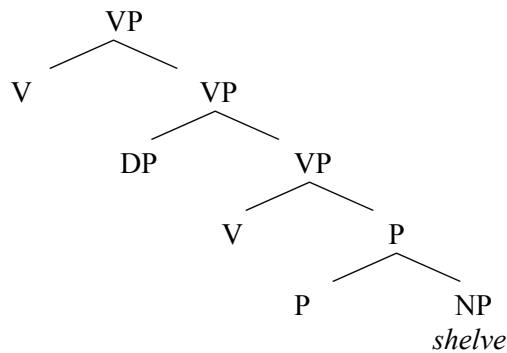

According to H&K (1993), the complement of P, *shelve*, undergoes successive *Head Incorporation*, first to the empty P and then onto the empty V, obeying syntactic principles. In a more recent account (H&K 2002), the process of incorporation is replaced by that of *conflation*, which involves copying the phonological signature of the complement into the head. Both accounts are finally abandoned in favor of a *selection* analysis (H&K 2002 2005): H&K argue that the phonological content of denominal verbs is base-generated.<sup>83</sup> More specifically, they suggest that the *selectional* features of the lexical item associated with the V head are rich enough to license an empty complement or, else, an overt complement that would fit as a hyponym of the lexical item. That is schematized as in (23). The lexical item *shelve* is base-generated and not incorporated or conflated from its PP complement.

<sup>83</sup> The incorporation analysis is still considered for deadjectival predicates (*redde*, *thicken*) and transitive predicates such as *break*, where the unaccusative *break* is argued to incorporate onto the transitive *break*.

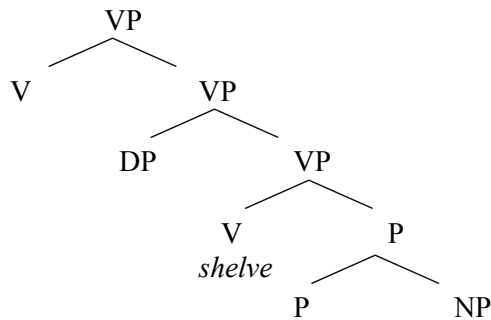
(23) L-SYNTAX STRUCTURE OF *SHELVE*; *SELECTION ANALYSIS*

On the basis of the ungrammaticality of Source-based and Scale-based location predicates, I suggest that there cannot be a silent V selecting for a PP in location predicates, like H&K argued in their 1993 paper. If such a head existed, nothing would prevent SourcePs or Approximate ScalePs from becoming location verbs. A predicate like *joan* ‘go’ can take a SourceP or an Approximate ScaleP as complement:

- (24) a. Neskak etxe-tik joa-n dira  
 girl.ABS home-ABL go-TU be.3plABS  
 ‘The girls have gone out of the house’  
 b. Neskak bere-ganantz joa-n dira  
 girl.ABS him/her-APPROX go-TU be.3plABS  
 ‘The girls have gone towards him/her’

If the overt *joan* ‘to go’ can take a SourceP (24a) or an approximate ScaleP (24b) as complement, we do not have an explanation of why its silent counterpart is not able to do that. Similarly, in the *semantic selection* approach, it is unclear why *etxera-tu* is a good location predicate while *\*etxetik-tu* is not. If the bundle of LIs *etxe-ra* is rich enough to license a non overt <sub>PP</sub>[P NP] complement, *etxe-tik* would also be rich enough to license a non-overt PP complement. Nevertheless, *etxe-tik* is not a good lexical candidate to form a location predicate, whereas *etxe-ra* is. I believe that something else is needed in order to account for the Goal-Source asymmetry found in location predicates: an analysis which needs to take into account the eventive-adpositional homomorphism. As I have mentioned before, I claim that the allative *ra* is directly inserted in *procP*, and that it spells out both *proc* and *res*.

#### 5.2.4. Events and adpositions

We have seen that location predicates can only be built on a GoalP. The *-tu* suffix can only be attached to the allative adposition and not to the ablative or the

approximative. Consider now the parallelism between the inner structure of events (the one proposed in the *First Phase Syntax*) (25a) and the inner structure of adpositions (Svenonius 2006, Pantcheva 2011) (25b). Actually, Ramchand (2008a: 41) notes that if the core dynamic event is viewed as paralleling the topological properties of a path, the dynamic portion would be the process, the initiation point or source would be the initiation, and the end point would be the result.

(25) a. EVENT DECOMPOSITION (Ramchand 2004 et seq.)

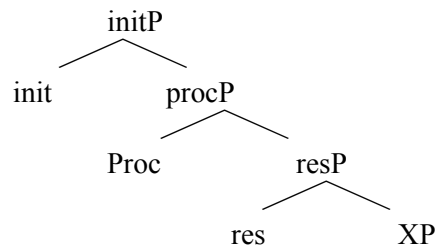

b. ADPOSITION DECOMPOSITION (Svenonius 2006, Pantcheva 2011)

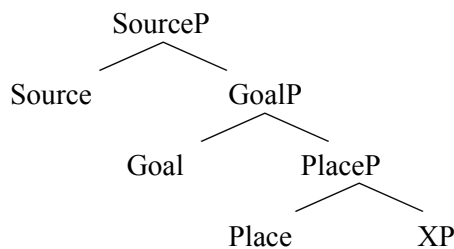

The decomposition of events and the decomposition of adpositions is structurally isomorphic: the Source head can be paralleled to *init*; the Goal head to *proc*; and the Place head to *res*. With this parallelism in mind, we can understand the restriction of location verbs on GoalPs. The LI *-ra*, corresponding to the Basque allative adposition, is optionally lexically associated with a GoalP node or with a *procP* node, because these two heads are topologically and structurally equivalent. Other adpositions, like the ablative or the allative approximative, cannot be associated with *procP* because their stored tree does not match that of *procP*.<sup>84</sup>

<sup>84</sup> Someone could argue that, basing on the Superset Principle (e.g. Starke 2009), the ablative and approximative LIs can match the *procP* node, since their stored trees are a superset of the syntactic tree which has to be lexicalized. Nevertheless, recall that the formulation of the Superset Principle in Ramchand (2008b: 121) also stipulates “where several Vocabulary items meet the conditions for insertion, the item containing fewer features unspecified in the node must be chosen”. Thus, in a context where the allative, the ablative and the approximative LIs compete for insertion, the allative would be inserted, since it does not contain any feature not specified in the syntactic node.

Regarding the lexical insertion of *-tu*, I claim that, in this kind of location predicates, it only lexicalizes the [nP [n]] node. This is actually what I suggested for non-derived predicates (sec. 3.2.2) and predicates built on Event naming Roots (sec. 4.2.1.1).

### 5.2.5. Conclusion

In this section, I have explored the nature of location predicates in Basque. I have shown that the adpositional phrase occurring in location predicates consists of GoalP and PlaceP. Other projections that can be added on top of GoalP are excluded from the domain of possible location predicates, as shown by the ungrammaticality of location predicates built on the ablative or allative approximative phrases: *\*etxe-tik-tu*, *\*etxe-rantz-tu*. I have argued that the allative *ra* is the only LI which can be lexically associated with the node procP, because *ra* spells out GoalP, and procP and GoalP are topologically and structurally equivalent.

It is worth pointing out that English location predicates pose the same Goal/Source asymmetry. To my knowledge, all derived location predicates involve a Goal path, rather than a Source (i.e. *shelve* means to put sth on a shelf, rather than take sth from a shelf) a fact which may suggest that the limit of possible location predicates claimed in this section is not restricted to Basque, but that it may also hold cross-linguistically. Further research is needed in this aspect.<sup>85</sup>

PlacePs are also generally not accepted in location predicates (*\*etxe-an-tu*), a fact which finds a correlate in cross-linguistic patterns of grammaticalization. As noted in Yamaguchi (2004), Place adpositions are usually grammaticalized to stative predicates, whereas Path adpositions like the allative are usually involved in motion predicates or predicates of seeing implying a directed gaze.

Finally, another important finding of this study on location predicates concerns the existence of the verbal category. I have argued that, against Hale & Keyser (1993), an empty V cannot be posited to be present in location predicates. Instead, the LI *ra* is directly inserted in *proc* because its topological structure is compatible with it. This implies that the *proc* head might not be verbal after all, since *ra*, which usually spells out an adposition, can lexicalize it. This fact leads us to the question of whether the

---

<sup>85</sup> In relation to that, it is interesting to note that in Basque, the only way to get a derived location predicate with a Source meaning is having a negative affix before the Place denoting noun: *des-erri-ra-tu* (neg-country-ALL-tu) 'to exile, to banish'. This data is nicely related with the analysis of the Source path made in Pantecheva (2011), where it is argued that Source introduces a reverse operation.

verbal category does really exist in Basque and whether it can be really defined in syntactic terms. In section 5.3, I will show that *-tu*, the morpheme which apparently seems to turn anything into a verb, cannot be considered to be of verbal category either.

### 5.3. CONSIDERATIONS ON THE CATEGORY OF *-TU*

In section 5.2, I have shown that the allative *ra* can lexicalize the *procP* node, and I have concluded that *proc* does not necessarily be of verbal category. In this section, I will show that *-tu* is not verbal either. As a matter of fact, predicates headed by *-tu*, both in the analytic configuration and in non-finite contexts, fit better within the nominal category. The nominal distribution of non-finite forms of predicates is not a weird characteristic of Basque. For instance, it is a well-known fact that non-finite predicates behave as nouns in several aspects and that they can be selected by heads which usually select nominal elements, such as P or D (e.g. Kayne 2000, Haddican 2007, Alexiadou et al. 2011).

This way, I claim that both *-tu* and *-tze* (of *-tze-n*, used in the imperfective analytic configuration) (see chapter 8) have nominal category. The nominal category of *-tze* is standardly assumed in the literature: predicates headed by *-tze* have been traditionally considered verbal nouns (Euskaltzaindia 1997 [1987]), and the *-tze* suffix has been analyzed as a nominalizer (Goenaga 1985, Ortiz de Urbina 1989, Mateu & Amadas 1999, Demirdache & Uribe-Etxebarria 2000, Laka 2004 2006a). For instance, *-tze* headed predicates can be used as common nouns (e.g. *has-te* ‘beginning’, *sar-tze* ‘entrance’, *sines-te* ‘believe’), and be combined with nominal case marking. These are some examples:

- (26) [Ane berandu etor-tze-a-k]<sup>86</sup> harritu ninduen *ergative*  
 [Ane.ABS late come-TZE-DET-ERG] surprised me  
 ‘It surprised me that Ane came late’
- (27) [Ohera joa-te-a] gomendatzen dizut *absolute*  
 [bed-ALL go-TZE-DET.ABS] recommend you  
 ‘I recommend you to go to bed’
- (28) Ondo deritzot [zinemara joa-te-a-ri] *dative*  
 It seems to be good [cinema-ALL go-TZE-DET-DAT]  
 ‘Going to the cinema seems okey to me’
- (29) Pozten naiz [zu hemen ikus-te-a-z] *instrumental*  
 I am glad [you.ABS here see-TZE-DET-INSTR]  
 ‘I am glad to see you here’
- (30) Ez nago ados [zu-k saria irabaz-te-a-rekin] *sociative*  
 I do not agree [you-ERG prize.ABS win-TZE-DET-SOC]  
 ‘I do not agree with you winning the prize’

<sup>86</sup> The morphemes that are out of the brackets in these examples are not directly glossed.



- (31) a. Aingeru lan egi-te-n ari da  
 Aingeru.ABS work do-TZE-INE PROG be.3sgABS  
 ‘Aingeru is working’  
 b. [Aingeru etor-tze-a-n] afalduko dugu *inessive*  
 [Aingeru.ABS work-TZE-DET-INE] we will have dinner  
 ‘We will have dinner when Aingeru comes’
- (32) [Amama ikus-te-ra] joango gara *allative*  
 [grandmother.ABS see-TZE-ALL] we will go  
 ‘We will go to see the grandmother’
- (33) [Amama ikus-te-ko] joango gara *genitive*  
 [grandmother.ABS see-TZE-GEN] we will go  
 ‘We will go to see the grandmother’

Note that in most of these cases, *-tze* headed predicates do not lose their “verbal” properties: it is able to select a direct object marked absolutive, and it is combined with ergative external arguments (see among others Artiagoitia 2003, San Martin 2004 2011 and Duguine 2013 for the distribution of case-marking in these kinds of clauses).

Now, I will show that *-tu* headed predicates have nominal category as well. In order to support this claim, I will present some pieces of data where *-tu* headed predicates appear within DPs and PPs.

Let us begin with the contexts where *-tu* is headed by a determiner. When *-tu* predicates appear headed by the determiner *-a*, they usually behave like adjectives, showing plural number agreement. For instance, the perfect of result in Basque is instantiated by a predicate headed by *-tu* and the determiner *a*.<sup>87</sup>

- (34) bezeroak etorr-i-a-k dira  
 guest.ABS come-TU-DET-pl be.3sgABS  
 ‘The guests are come’

The combination of a determiner and a *-tu* predicate is equivalent to the selection of a noun or an adjective by the determiner *-a*, which results in a DP.

- (35) a. mendi-a-k  
 mountain-DET-pl  
 ‘the mountains’

<sup>87</sup> The *-a* suffix selecting for *-tu* predicates is different from the referential determiner, whose exponent is also the *-a* suffix (see e.g. Artiagoitia 1997, Eguren 2000 for the ambiguous use of *-a* in predicative constructions involving nouns and adjectives). Moreover, its determiner status can also be questioned, since determiners do not typically select for adjectives. As a matter of fact, Eguren (2000) claims that the *-a* suffix of predicative constructions is the exponent of a Pred head (Baker 2003). For our discussion, this matter is not strictly relevant, since Pred also selects for elements having nominal or adjectival category, and thus, the selection of *-tu* predicates by *-a* is still a piece of evidence in favor of the adjectival/nominal category of *-tu* predicates.

- b. mendi altu-a-k  
 mountain tall-DET-pl  
 ‘the tall mountains’

The adjectival participles formed by *-tu* + *-a* can actually be modified by comparative suffixes (36) (Hualde 2003a: 204-205) as common adjectives (37).

- (36) a. irakasgai ikas-i-en-a  
 subject study-TU-SUP-DET  
 ‘the most studied subject’  
 b. pelikula ikus-i-en-a-k  
 film see-TU-SUP-DET-pl  
 ‘The most seen film’
- (37) mendi altu-en-a-k  
 mountain tall-SUP-DET-pl  
 ‘the tallest mountains’

I claim that the adjectival interpretation and categorization of the predicates is derived from the presence of the Asp head responsible for viewpoint aspect, in this case defined as the spatiotemporal predicate AFTER (Demirdache & Uribe-Etxebarria e.g. 2005, see chapter 8). These examples, thus, do not directly reflect the nominal category of the predicate. Interestingly, when the head responsible for viewpoint aspect is not present, the nominal category of the predicate becomes apparent.

In the following examples, *-tu* headed predicates appear in DPs without having an “adjectival” status. Some *-tu* predicates can form copulative compounds of nominal category (38) (Euskaltzaindia 1997[1987], de Rijk 2008) and combine with determiners (39) in argumental positions. When this happens, the new nominal can hold plural number features and can trigger plural agreement on the auxiliary, as regular DP arguments do (39a).

- (38) a. hartu-eman                    ‘interchange, relation, lit. to take-to give’  
 b. joan-etorri                    ‘round trip, lit. to go-to come’  
 c. sartu-irten                    ‘small visit, lit. to enter-to go out’  
 d. jan-edan                    ‘diet, food and drink, lit. to eat-to drink’
- (39) a. Geure hartu-eman-a-k indar-tu    behar ditugu  
 our relation-DET-pl reinforce-TU    must have.1plERG.3plABS  
 ‘We have to reinforce our relations’  
 b. Sartu-irten bat egi-n zuen                    atezaina-ren-ean  
 small.visit DET do-TU have.3sgERG.3sgABS.PST caretaker-GEN-INE  
 ‘I made a small visit in the house of the caretaker’ ‘I paid a small visit to the caretaker’  
 [J. Urteaga, 2002: 21]

Additionally, there are several lexicalized instances in the language where non-compound *-tu* predicates are selected by determiners such as *bat* or *-a* (e.g. Euskaltzaindia 1997[1987], Hualde 2003a: 204, Artiagoitia 2003: 665).

- (40) a. *begira-tu bat*  
 look.at-TU DET  
 ‘a look’  
 b. *uki-tu bat* (Hualde 2003a: 205)  
 touch-TU DET  
 ‘a touch’  
 c. *urra-tu bat*  
 scratch-TU DET  
 ‘a scratch’  
 c. *irabaz-i-a-k*  
 win-TU-DET-pl  
 ‘winnings’
- (41) *Pedro Huizi azken uki-tu-a-k emai-te-n ari zitzaion santa*  
 Pedro Huizi.ABS last touch-TU-DET-PL give-TZE-INE PROG be.3sgABS.3sgDAT saint  
*Klararen erretratua-ri*  
 Klara-GEN portrait-DAT  
 ‘Pedro Huizi was giving the last touches to santa Klara’s portrait’  
 [J.M. Irigoien, 2000: 314]

Now, I will show that *-tu* headed predicates can also be selected by P. Firstly, the way in which future tense reference is realized in Basque is remarkable. This form is built adding the *-ko/-en* suffix, which are homophonous with the relational suffix or the genitive (glossed genitive –GEN), to the *-tu* ending predicate. The fact that *-ko/-en* selects for *-tu* headed predicates can be considered another proof for the nominal category of *-tu*.

- (42) *Ametsek bihar dantza-tu-ko du*  
 Amets-ERG tomorrow dance-TU-GEN have.3sgERG  
 ‘Amets will dance tomorrow’

In the nominal domain, the genitive *-ko* selects for bare NPs or allative phrases. I argue that the selection of *-tu* predicates by the relational *-ko* mimics the selection of NP *-etxe* ‘house’ in (43a) by *-ko*. I will go deeper on this issue in chapter 8, section 8.7.2.

- (43) a. *Etxe-ko mahaia*  
 house-GEN table  
 ‘The table of the house’

- b. Etxe-ra-ko bidea  
 house-ALL-GEN way  
 ‘The way home’

On the other hand, another interesting aspect of predicates headed by *-tu* is that they can be the complements of Axial Part heads in temporal clauses, as discussed by Uribe-Etxebarria (2014) (see also Hualde 2003a: 204). As commented in section 5.2.1, in a decomposition analysis of adpositions, PlaceP further embeds an Axial Part head (Svenonius 2006 2008). Basque postpositions or locational nouns like *aurre* ‘front’, *arte* ‘among, between’, *azpi* ‘under’ and *inguru* ‘space around’ (Euskaltzaindia 1991[1985], de Rijk 2008, Eguzkitza 1997, Hualde 2002) have been considered, in their projective interpretation, instances of Axial Parts (Etxepare 2013).

- (44) a. Etxe-aurre-an  
 house-front-INE  
 ‘In front of the house’  
 b. Aulki-azpian  
 chair-under-INE  
 ‘Under the chair’  
 c. Zuhaitz-arte-an  
 tree-between-INE  
 ‘Among the trees’

As Uribe-Etxebarria (2014) has pointed out, Basque makes use of AxialPart heads in order to form temporal clauses like (45). In these examples, the AxialPart heads (*aurre* ‘front’/*oste* ‘back’) and the adpositions (*-tik* ‘from’/*-an* ‘in’) head PPs ordered in time. As can be seen, the Ps *aurretik* ‘before, lit. from the front’ and *ostean* ‘after, lit. in the back’ select for *-tu* headed predicates and order them preceding or following the event denoted in the main clause. It thus seems that Basque organizes in a parallel fashion events and entities in time and space, by means of AxialPart heads and adpositions.

- (45) a. Miren etorr-i oste-an joa-n naiz etxe-ra  
 Miren.ABS come-TU back-INE go-TU be.1sgABS home-ALL  
 ‘I have gone home after Miren came’ lit. I have gone home in the back of Miren coming’  
 b. Miren etorr-i aurre-tik joa-n naiz etxe-ra  
 Miren.ABS come-TU front-ABL go-TU be.1sgABS home-ALL  
 ‘I have gone home before Miren came’ lit. I have gone home from the front of Miren coming’

In the spatial domain, *AxialParts* combine with bare NPs, as seen in (44). In the temporal domain, they combine with *-tu* headed predicates, showing again that *-tu* has nominal category.

Another piece of evidence in favor of the nominal category of *-tu* non-finite forms is that they can be the complements of *gabe*, the equivalent of the English preposition ‘without’ (Hualde 2003a, de Rijk 2008, Haddican 2007, Haddican & Tsoulas 2012). In Basque, de Rijk (2008) points out that in old words *gabe* seems to be a noun, meaning ‘lack’ or an adjective, meaning ‘devoid’, and that nowadays, it has evolved into a stative adverb or a postpositon. Recall that, in chapter 3 (sec. 3.2.1.1), I classified *X-gabe-tu* predicates within deadjectival predictates. As mentioned then (fn. 21), I follow Mateu (2002) in considering that adjectives are decomposed into a relational and a non-relational element. Thus, the adjectival status conferred to *gabe* must be related to the fact that *gabe* is an overt instance of the relational element that adjectives have. Thus, I consider that, *gabe*, in isolation, can be characterized as an adposition.

*Gabe* ‘without’ can combine with bare nouns (46a), with partitives (46b), with the indefinite determiner *bat* (46c), definite DPs (46d), and also, crucially, with the *-tu* headed predicates (46e):

- (46) a. *Diru gabe, beldur gabe*  
 money without, fear without  
 ‘without money’ ‘without fear’  
 b. *diru-rik gabe, beldur-rik gabe*  
 money-PART without, fear-PART without  
 ‘without money’, without fear’  
 c. *hitz bat gabe, euro bat gabe*  
 word DET without, euro DET without  
 ‘without a word’, ‘without an euro’  
 d. *zu gabe, hori gabe*  
 you without, that without  
 ‘without you’, without that’  
 e. *ezer esa-n gabe, ikus-i gabe*  
 nothing say-TUI without, see-TUI without  
 ‘without saying anything’, ‘without seeing anything’

The selection of *-tu* non-finite forms by *gabe* can be argued to be the parallel of the selection of bare NPs by *gabe*, as in (46a). What can be clearly stated is that *gabe* selects for elements of nominal category, and that it is incompatible with elements of verbal category (those lexicalized out of the first phase domain, according to my analysis, see chapter 8). Consider, for instance, the examples below. *Gabe* ‘without’

can combine neither with Basque synthetic verbs nor with finite Spanish or English verbs.

- (47) a. \*nator           gabe  
           come.1sgABS without  
       b. \*without I come  
       c. \*sin           vengo  
           without come.1sg

- (48) a. ni    etorri   gabe  
           I.ABS come-TU without  
       b. without me coming  
       c. sin    yo venir  
           without I come.INF

In contrast, it is compatible with the Basque *-tu* predicate, as well as with the English *ing* form of the verb and the Spanish infinitive.

All in all, in this section, I have shown that *-tu*, the suffix heading predicates in the analytic perfect/perfective configuration and in the infinitive form is really of nominal category. In this sense, it is similar to *-tze*, which is standardly assumed to be a nominalizer. This claim raises interesting questions about the existence of the verbal category in Basque. Note that, in Basque, the analytic configuration is predominant in comparison with the synthetic form: it is used in perfect/perfective and imperfective contexts and it is the only productive configuration. If in all these cases, the predicate is of nominal category, it is not clear where the verbal category is exactly lexicalized. Someone can think that the nP –spelled out by *-tu*– selects for a verbal phrase, so that the verbal category would be syntactically represented in what I have called the stem of the predicate. However, as I have shown in chapter 3, chapter 4 and section 5.2, in most predicates, the LIs spelling out the stem are also used in nominal, adjectival and even in adpositional contexts. Particularly, in the case of location predicates analyzed in section 5.2 (e.g. *etxe-ra-tu* ‘to go/take sb home’), the stem corresponds to an allative phrase (*etxe-ra* ‘to home’). I have proposed that the allative *ra* lexicalizes the procP node, because *proc* and Goal are topologically and structurally equivalent. Thus, it follows that V does not really exist, since adding a verbal category to the allative *ra* would overgenerate.

For these reasons, and other arguments that will be discussed in chapter 8, I will adopt the view that the lexical category *verb* does not syntactically exist, and that it is a postsyntactic construct derived from the environment in which a predicate is lexicalized. See section 5.4 for some reflections on the nominal categorization of Roots in relation to the nominal category of the predicates.

## 5.4. ABOUT CATEGORIZATION

### 5.4.1. The Generalization on Roots and abstract Case

In chapter 3, I have concluded that a Root which is spelled out separately from its respective subeventive head surfaces as a nominal, and that, as such, it has to be case-licensed. This was stated in the Generalization on Roots.

(49) Generalization on Roots

Roots surface as nominals and need to be case-licensed if they are lexicalized separately from their respective subevent.

This generalization explains why complex unergative predicates cannot take an internal object other than the Root. In complex unergatives, the Root is spelled out separately from *proc*, and therefore, it has to be case-licensed. Since there is only one case-assigner available, the Voice head, only one object can surface.

As mentioned in chapter 4, fn.64, the case requirement of Roots, as formulated in this generalization, is reminiscent of the Incorporation analysis made in Baker (1988). According to Baker (1988), a noun which incorporates onto a verb does not need to be assigned Case from the verb, and thus, the Case assigning potential of the verb is not exhausted. The difference is that the Generalization on Roots applies in lexical insertion, and does not necessarily correspond to syntactic movement.

Note that, by means of the Generalization on Roots, I am not getting rid of abstract Case. The Case requirement of Roots is dependent on their nominal category which, according to the Generalization (49), depends on the configuration in which a Root is lexicalized. However, recall that in this dissertation I am assuming Cyclic Spell Out (Caha 2010, Pantcheva 2011), which states that the lexicon is accessed after every external merge.

(50) Cyclic spell out (Pantcheva 2011: 129)

Each step of External Merge is followed by lexical access. There is not lexicalization cycle after Internal Merge.

Basing on the Generalization on Roots and on Cyclic Spell Out, the categorization of Roots (nominal or non-nominal category) will be determined as soon as the subeventive node (*procP* or *stateP*) is sent to spell out. If the Root is lexicalized by the

same LI spelling out the subeventive node, it will have non-nominal category, and will not have to be case-licensed. On the contrary, if the subeventive node is spelled out by another LI—different from the LI lexicalizing the Root—, then the Root will be nominal and will have to be case-licensed.

Crucially, by the time Voice is merged, the (non-)nominal category of the Root will be already determined, and, in the case the Root has ended up being nominal, Voice will assign case to it. Therefore, even though the nominal category of Roots is not determined from the beginning, case-requirements are present in syntax, and must be satisfied by the corresponding case-assigners.

#### 5.4.2. Results revisited: lexicalization and categorization

The Generalization on Roots applies nicely to the Roots associated with state subevents. Recall that, in chapter 3, I suggested that in change of state predicates like *ama-tu* ‘to become a mother’ and *apur-tu* ‘to break’, the LIs *ama* ‘mother’ and *apur* ‘bit’ are lexically associated to a state subevent which takes a Root as complement. I claimed that the lexical entry of *ama* is the following:

- (51) *ama* ↔ < /ama/, stateP, (conceptual content) >.
- ```

stateP
├── state
└── Root

```

The Root that *ama* lexicalizes appears also in nominal contexts. But, nevertheless, I have not heard of any work suggesting that, in a predicate like *amatu* ‘to become a mother’, the nominal *ama* needs to be case-licensed. This is precisely because, even though *ama* is a Root potentially occurring in nominal contexts,<sup>88</sup> it is not a nominal when it is part of a change of state predicate. This follows from the Generalization on Roots. In the change of state predicate, the LI *ama* lexicalizes both the Root and stateP (=res). Thus, the Root is not separately lexicalized, it does not surface as a nominal and does not need to be case-licensed.

Consider now a location predicate like *etxe-ra-tu* ‘to go/take sb home’. In section 5.2, I claimed that the allative *ra* lexicalizes both GoalP and PlaceP, which are actually the parallel, in the eventive domain, of procP and resP. Focusing on the result subevent, I suggest that the adposition by itself must be regarded as the parallel to the

<sup>88</sup> As commented in chapter 3, fn. 23, I am not claiming that *ama* always spells out a state node. This only happens when a state head selects for the Root lexicalized by *ama*.



state subevent of the previous case, and its complement, the noun *etxe* ‘home’, as its Root complement. The Root *etxe* is not lexicalized by the same LI spelling out the state subevent (*-ra-*), and therefore, surfaces as a noun. This noun ends up in a successful derivation, so that, I suggest that, in those cases, the relational element (*res*, lexicalized by the allative *ra* –together with *proc*) actually licenses it. As a consequence, the noun *etxe* ‘house’ does not need to be case licensed by a case-assigning head, i.e. Voice). Derived location predicates, then, would also obey the Generalization in Roots.

The categorization analysis of Roots put forward in the Generalization is related to the argument structure types and their connections to categories made in Mateu (2002) and Mateu & Rigau (2002). In these proposals, it is claimed that adpositions, adjectives and adverbs share the same argument structure where a relational element *x* takes a non-relational element *y* as complement (*z* being the specifier).

(52)  $[_{XP} z [ x [ y ] ] ]$

More specifically, they suggest that adjectives and adverbs must be regarded as instances of relational elements (*x*) into which a non-relational element (*y*) has been incorporated/conflated. Thus, these three sentences are decomposed into the same primitives:

(53) a. The cat is  $[_x \text{ in } [_y \text{ the room}]]$   
 b. The cat is  $[_x \emptyset [_y \text{ happy}]]$   
 c. The cat is  $[_x \emptyset [_y \text{ here}]]$

According to Mateu & Rigau (2002: 215), the non-relational semantic feature entails the nominal category, whereas the relational feature entails prepositional or verbal category. Thus, adjectives and adverbs are lexicalizations of both P and N categories: *happy* and *here* involve a silent P to which N has been incorporated. This is closely related to the Generalization on Roots, and the analysis of change of state predicates presented in chapter 3. In the predicate *gorritu* ‘to redden’, *gorri* is an LI lexicalizing stateP, headed by the state subevent (a relational element of central coincidence) and a Root (its Ground). If the state head and its Ground complement are lexicalized separately, as it happens in the complex deadjectival *etxe-gabe-tu* ‘to evict’ or in the location predicate *etxe-ra-tu* ‘to go/take sb home’, the Root in complement position of the state head surfaces as a nominal. Thus, if the Root and its state subevent are lexicalized together, the LI will be considered to have non-nominal

category, whereas if the Root and its state subevent are lexicalized separately, the Root will surface as a nominal.

### 5.4.3. Lexical and syntactic categories

This analysis of the categorization of Roots has interesting results for the categorization process as a whole. In the Principles & Parameters framework, lexical categories were differentiated on the basis of opposite values of two binary features (Chomsky 1979):  $\pm N$  and  $\pm V$ . Nouns, verbs, adjectives and adpositions were defined as different combinations of these features: nouns are [+N, -V], verbs are [-N, +V], adjectives are [+N, +V] and adpositions are [-N, -V]. Nevertheless, in more recent accounts, it is standardly assumed that the feature system of categories does not explain the nature of categorial distinctions (e.g. Déchaine 1993 2005, Baker 2003). In approaches made within DM, like those made by Marantz (1997 2001 2007), lexical categories are reformulated as a-categorial roots which get their label from functional phase heads. Thus, a Root becomes a noun (an NP) because it is dominated by the phase head *n*. On the other hand, Baker (2003) proposes that lexical categories (nouns, verbs and adjectives for him) are defined syntactically: nouns as the syntactic objects having a referential index, verbs as syntactic objects having a specifier and adjectives as objects having neither a referential index nor a specifier.

The analysis put forward in chapter 4, however, does not support any of the approaches just mentioned. Instead, it suggests that the nominal category of Roots emerges as a consequence of the configuration in which a Root is spelled out. A functional head *n* is not involved in this process, nor a referential index is present in the Root. Baker (2003: 96) suggests that a syntactic node cannot license a specifier and have a referential index at the same time. In this way, he makes the correct distinction between verbs and nouns. As supporting evidence, he points out that change of state predicates are not built on nouns cross-linguistically. He argues that a noun cannot conflate to Pred (a functional head introducing specifiers above adjectives and nouns) to yield stative or inchoative predicates, but that adjectives, in contrast, are usually involved in such a conflation process. For example, the predicate *man* does not have the meaning of ‘to become a man’, but the predicate *open*, derived from an adjective, has the meaning ‘to become open’. He argues that the reason for this contrast lies in the fact that nouns bear referential indexes. The referential index is stated as an ordered pair of integers where “the second member [...] must be identical

to an index of its sister (theta-role assignment) or to the index of a dependent element that it c-commands (chain-formation) (p. 96). This implies that all objects having a referential index must be assigned a theta role. From this, it follows that an object bearing a referential index cannot be a predicate. The conflation contrast between nouns and adjectives is argued to hold cross-linguistically in Baker (2003), but, as shown in chapter 1, it cannot be applied to Basque. Basque is full of inchoative verbs derived from Roots which usually surface as nominals (e.g. *ama-tu* ‘to become a mother’ from *ama* ‘mother’, *apaiz-tu* ‘to become a priest’ from *apaiz* ‘priest’ etc.). Therefore, an approach to the nominal category where a Root like *ama* ‘mother’ bears a referential index and where this ensures that *ama* surfaces as a noun cannot be maintained for Basque.

In order to account for the data presented in this dissertation, we need a theory of categorization which is not articulated based on inherent properties of the syntactic objects and which is not fully determined by syntax. Thus, my analysis of Basque data is closer to an approach where there are no lexical categories such as N and V in syntax. In Déchaine & Tremblay (in prep) and Déchaine (2005), it is argued that LIs are categorized according to their syntactic environment. If an object *x* is in the context of Aspect, *x* will be categorized as a VP, and if *x* is in the context of D, *x* will be categorized as an NP. Nevertheless, this theory of categorization is still insufficient since it does not take into account the lexicalization configuration. For instance, in section 5.4.2, I have argued that, in a change of location predicate like *hurbildu* ‘to get/put closer’ and *etxeratu* ‘to go/take sb home’, the Root surfaces with nominal or non-nominal category depending on how it is lexicalized: *hurbil* is non-nominal because it is lexicalized together with the state head, whereas *etxe* is nominal because it lexicalizes apart from it. Both Roots are in the same syntactic context, but they emerge with a different category.

Some theories of categorization make a minimal distinction between syntactic categories. For instance, Kayne (2008) proposes that there are only two syntactic categories: nouns and non-nouns. This distinction follows from antisymmetry in the sense of Kayne (1994). LCA (Linear Correspondence Axiom) states that an element *x* is linearized before an element *y* if *x* asymmetrically c-commands *y*. In a head-head merge, like  $\{y, x\}$ , *y* and *x* c-command each other and, according to the LCA, they cannot be linearized. Following a proposal from Guimarães (2000), Kayne (2008) suggests that some heads are able to merge with themselves (Self-Merge), creating, this way, singletons. If *x* merges with itself,  $\{x\}$  is formed, a set consisting of only *x*.

The Merge of  $y$  and  $\{x\}$  is not a problem for LCA, since, now,  $y$  asymmetrically c-commands  $x$ . Kayne (2008) suggests that category distinctions are derived from the ability of an element to become a singleton. Some lexical items can be involved in singleton formation, while others cannot. According to him, items that can undergo singleton formation do not have unvalued features (given that unvalued features have to be valued as soon as possible when entering the syntactic derivation, Chomsky 2001). Building on Collins (2005), he suggests that parametric variation is a property of unvalued features. Since parameters are fixed by the language faculty, Kayne points out that they constitute a closed set. From these conjectures, Kayne concludes that elements of category  $y$  (those not involved in singleton formation) must be the locus of unvalued features, and, therefore, of parametric variation. Since parameters represent a closed set, Kayne suggests that the category  $y$  must be closed. Kayne claims that  $x$  is a noun and that  $y$  is a non-noun. Nouns and non-nouns are defined this way:

- (54) a. **x**: open class, singleton-set formation, initially valued features, not locus of parametric variation.  
 b. **y**: closed class, no singleton-set formation, initially unvalued features, locus of parametric variation.

According to him, nouns have neither complements nor specifiers, since they invariably form singletons when they enter the syntactic derivation. Verbs fall within the class of non-nouns. He claims that verbs are all light verbs (which may involve a noun, as in unergatives like *laugh*, Hale & Keyser 1993), so that they constitute a closed class.

Boeckx (2015) has also a view where categories are minimally specified. Basing on the phasal labeling idea developed by Marantz (2001 2007), Boeckx claims that phase heads label its dominated head, and by virtue of this labeling the phase head obtains its identity. Consider the set  $\{\alpha, \beta\}$  where  $\alpha$  is a phase head:  $\beta$  is labeled by  $\alpha$  and  $\alpha$  is the label of  $\beta$ . In Boeckx's system, the category assigned depends on a minimal distinction: whether the complement of the phase head is a singleton or a two-member set. Consider that other heads,  $\gamma$  and  $\delta$  are merged to  $\{\alpha, \beta\}$ , yielding  $\{\delta, \gamma, \alpha, \beta\}$  where  $\delta$  is a phase head. When  $\delta$  is merged the complement of the phase  $\alpha$  is sent to spell out. Thus, the complement of  $\delta$  is the two-membered set  $\{\gamma, \alpha\}$ .  $\alpha$  has already an identity, so that  $\delta$  labels  $\gamma$ . Since labels are syntactically differentiated only on the grounds of this singleton/two-membered set distinction, there are only two

categories emerging from syntax; that assigned by phase heads which have a singleton as complement (i.e.  $\alpha$ ), and that assigned by phase heads which have a two-membered set as complement (i.e.  $\delta$ ). Boeckx (2015) terms the former phase type intransitive and the latter phase type transitive.

Boeckx (2015) does not match intransitive complements directly with the language-specific nominal category, but he notes that intransitive complements are “predisposed to manifest nominal behavior post-syntactically” (p.46). Transitive complements, on the other hand, are not so closely related to a given category, since they group many categories like adpositions, verbs, adjectives and all functional categories. Boeckx (2015) suggest that all these more specific categories are the post-syntactic configurational variants (specializations) of the two-category system provided by syntax.

The proposal about the categorization of Roots made in this dissertation fits well with the theories which regard syntactic categories as minimally defined notions which later evolve into more sophisticated morpho-syntactic categories in a post-syntactic level, e.g. Boeckx (2015). Although I do not consider that the nominal category is syntactically defined, as it is done in Kayne (2008), the claim that a Root surfaces as a nominal when it is lexicalized separately from its subeventive head can be nicely related to the singleton status proposed for nouns in Kayne (2008). An LI (lexicalizing a Root) is of nominal category if it lexicalizes a singleton. An LI spelling out  $\{proc, Root\}$  or a Root which takes a DP as complement (the Root in  $\{Root, DP\}$  does not have nominal category, because it does not lexicalize a singleton. Only an LI lexicalizing  $\{Root\}$  has nominal category. Similarly, this proposal on Roots is also related to the intransitive/transitive complement categories proposed in Boeckx (2015). A Root which surfaces with nominal category is in an intransitive phase, in the sense that it does not contain another phase head (as it happens in complement taking Roots).

Nevertheless, both the singleton and the intransitive phrasal approach to categories run into problems when we get to the category of the predicate. Following the discussion of section 4, in chapter 8, I will argue that predicates occurring in the analytic configuration (the vast majority of Basque predicates) have nominal category: *-tu* and *-tze* affixes are nominal. I will argue that they surface with nominal category because they are lexicalized separated from Asp (viewpoint aspect). The syntactic heads that these affixes lexicalize are not singletons or intransitive phase

complements, so that their nominal categorization cannot be apparently accounted in the terms discussed in Kayne (2008) and Boeckx (2015).

#### **5.4.4. A note on the Generalization on Roots and *-tu***

As advanced at the end of section 5.4.3, in chapter 8, I will claim that Basque predicates surface with nominal category because they are lexicalized separately from the Asp head responsible for viewpoint aspect. Thus, the nominalization of predicates in analytic contexts seems to be related to the nominalization of Roots, as depicted in the Generalization. There is an important difference, though. When Roots surface with nominal category, there is not an additional nominalizer head (n) involved. In contrast, when predicates surface with nominal category, there are certain morphemes which seem to be realizing a nominalizer: *-tu* and *-tze*. In chapter 8, I will argue that *-tze* must be regarded as a Classifier/Divisor (Borer 2005a), and that this explains why *-tzen* predicates are usually exponents of habitual and progressive events. Regarding *-tu*, I will speculate that *-tu* may be lexicalizing a node semantically related to a left boundary (see ch.8, sec. 8.4.5). In any case, for convenience, I will keep using the nP node to represent the nodes lexicalized by *-tu* and *-tze* until chapter 8.

## 5.5. CONCLUSION

In this chapter, I have shown that the verbal category is syntactically absent in Basque. Firstly, I have analyzed predicates of change of location. I have suggested that Basque location predicates cannot be argued to be built on a silent V (cf. Hale & Keyser 1993), since, if that were the case, these predicates would be built on any type of Path adpositional phrase. Only allative phrases headed by *-tu* become location predicates. I have argued that only the allative can lexicalize procP because GoalP –the node lexicalized by the allative– and procP are topologically and structurally isomorphic. Other Path phrases, like SourceP or ScaleP cannot become location predicates, since their projections do not match that of procP.

- (55) a. *etxe-ra-tu*  
       house-ALL-TU  
       b. *\*etxe-tik-tu*  
       house-ABL-TU  
       c. *\*etxe-rantz-tu*  
       house-APPROX-TU

Another important conclusion of this chapter is that *-tu* predicates have nominal category. In chapter 3 and chapter 4, I have shown that *-tu* is used to form new predicates out of Property naming Roots, Event naming Roots, adpositions etc. From these facts, it can seem that *-tu* is really a verbalizer (in the sense of Marantz 1997). Nevertheless, in section 5.3 of this chapter, we have seen that *-tu* predicates have a nominal distribution, often appearing within DPs and PPs. If *-tu* is really of nominal category (as it is *-tze*), and V does not exist, it seems that the verbal category cannot be syntactically identified in Basque, not at least in analytic configurations. In chapter 8, I will continue developing this idea, building on the proposal made in Embick (2000), which suggests that a given Root can surface as a verb only if it is lexicalized in the local environment of T, and that it surfaces as an adjective if it surfaces below Asp. I will claim that the verbal category in itself does not syntactically exist and that is derived from the syntactic environment in which a predicate is lexicalized.

Finally, I have also considered the implications of the Generalization on Roots made in chapter 4 for the theory of categorization and its relation with the nominal category posited for in the case of predicates appearing in analytic configurations. I have argued that the nominal categorization of Roots as analyzed in chapter 4 is compatible with the conception of abstract Case, since by the time Voice –the case-assigner of Roots– is merged, the (non-)nominal category of the Root must have been

determined. On the other hand, I have shown that the Generalization, formulated in the context of the process subevent (see chapter 4, sec. 4.3)– applies nicely to state subevents. In the context of states, it correctly predicts when a Root will surface with nominal category, that is, when it is lexicalized separately from its subeventive node. This is precisely the case of location predicates like *etxe-ra-tu* ‘to go/take sb home’ and complex deadjectival predicates like *etxe-gabe-tu* ‘to evict’, and not the case of deadjectival or denominal predicates like *gorritu* ‘to redden’ and *amatu* ‘to become a mother’.

This analysis on the categorization of Roots requires a theory of categorization where lexical categories like N or V are not syntactically determined (e.g. Déchaine & Tremblay in prep). Additionally, the categorization of Roots as outlined in the Generalization also gets rid of labeling phase heads like little *n* (Marantz 1997 2001 2007), since the nominal category of Roots is just defined in terms of the configuration where the Root is lexicalized.





## **6. The boundary between eventivity and stativity**



## 6.1. INTRODUCTION

In this chapter, I will deal with the boundaries between stativity and eventivity. I will propose that a central coincidence relation is necessary in order to build a stative predicate, as claimed by Hale & Keyser (2002). Eventivity, on the other hand, emerges when the process head is projected in the structure (Fábregas & Marín 2012). As we will see, these two elements can be combined in the same configuration, and in some cases they give rise to stative and eventive properties.

In this chapter I will address the long-standing problem of those predicates which behave as eventive in some linguistic tests and as stative in others (e.g. *shine*, *lie*, *stand*). These predicates have been termed *Davidsonian* states (D-states) by Maienborn (2005 2007) and differentiated from *Kimian* states (K-states) –the canonical stative predicates (e.g. *know*, *own*). This opposition has also been analyzed in Rothmayr (2009) and Fábregas & Marín (2012). Following Fábregas & Marín, I will argue that the stative properties observed in D-states come from the lack of dynamicity and from the presence of an adposition of central coincidence. Nevertheless, I will propose that these two aspects are independent from each other. Particularly, I will claim that the adposition is precisely the inessive *-n* of the *-tze-n* suffix. The eventivity, on the other hand, comes from the projection of *proc*, as suggested by Fábregas & Marín.

In order to analyze the different behavior of D- and K-states, I will revise and apply to Basque the tests used to differentiate eventive from stative predicates, as well as dynamic from non-dynamic predicates. I will prove that certain Basque predicates, like *distiratu* ‘to shine’ belong to the class referred as D-states, and that other predicates, like *antza izan* ‘to resemble’ pattern with K-states. I will claim that D-states, contrary to K-states, project a *proc* head, and that their stative-like properties are derived from having a non-dynamic Rheme (see chapter 2, chapter 3 and chapter 4) and from the presence of the central coincidence *-n* of the *-tzen* suffix.

## 6.2. STATES

In the aspectual classification of verbs put forward in Vendler (1957/1967) and Dowty (1979), four different classes are identified: states, activities, achievements and accomplishments. Activities (e.g. *run*) and accomplishments (e.g. *write a letter*) denote processes going on time. According to Vendler (1957/1967), they consist of successive phases following one another in time. Achievements (e.g. *realize*) and states (e.g. *know*), in contrast, do not convey such a process: achievements occur in a single moment, and states, on the other hand, last for a period of time. Therefore, Vendler argues that a state predicate like *know geography* can last a period of time, like the activity *run*, but contrary to it, knowing geography does not consist of successive phases. There is not development implied. According to him, states involve time instants in an indefinite and non-unique sense. Some well known examples of English stative verbs that he mentions are *have, possess, desire, want, like, dislike, love, hate, rule, dominate, know* and *believe*.

There are a handful of tests used to discriminate between states and non-states (Vendler 1957/1967, Dowty 1979: 55-56). Only non-states can occur (i) in the progressive (1); (ii) as complements of ‘force’ and ‘persuade’ (2); (iii) as imperatives (3); (iv) with adverbs like *deliberately* and *carefully* (4); and (v) in pseudo-cleft constructions (5). Additionally, when placed in present simple, non-states get a habitual reading, while states can get an on-going, non-habitual meaning (6).

- |     |                                          |                       |
|-----|------------------------------------------|-----------------------|
| (1) | a. *John is knowing the answer           | <i>State</i>          |
|     | b. John is running                       | <i>Activity</i>       |
|     | c. John is building a house              | <i>Accomplishment</i> |
| (2) | a. *John forced Harry to know the answer | <i>State</i>          |
|     | b. John forced Harry to run              | <i>Activity</i>       |
|     | c. John forced Harry to build the house  | <i>Accomplishment</i> |
| (3) | a. *Know the answer!                     | <i>State</i>          |
|     | b. Run!                                  | <i>Activity</i>       |
|     | c. Build the house!                      | <i>Accomplishment</i> |
| (4) | a. *John deliberately knew the answer    | <i>State</i>          |
|     | b. John ran carefully                    | <i>Activity</i>       |
|     | c. John carefully built a house          | <i>Accomplishment</i> |
| (5) | a. *What John did was know the answer    | <i>State</i>          |
|     | b. What John did was run                 | <i>Activity</i>       |
|     | c. What John did was build a house       | <i>Accomplishment</i> |

- |     |                          |                               |
|-----|--------------------------|-------------------------------|
| (6) | a. John knows the answer | <i>On-going, non-habitual</i> |
|     | b. John runs             | <i>Habitual/Frequentative</i> |
|     | c. John builds a house   | <i>Habitual/Frequentative</i> |

Nevertheless, all stative predicates do not show a unitary behavior in these tests, some of them patterning more with non-stative predicates. As it is already noted in Dowty (1979: 173), some state predicates seem to be compatible with the progressive:

- (7)
- a. The socks are lying under the bed
  - b. Your glass is sitting near the edge of the table
  - c. The long box is standing on end
  - d. One corner of the piano is resting on the bottom step

This and other non-canonical behavior of some stative predicates have been recently addressed by Maienborn (2005 2007), Rothmayr (2009) and Fabregas & Marín (2012) (see section 6.2.2, and 6.3.1 for an analysis of this aspect in Basque).

In the following sub-sections, I will firstly present Hale & Keyser's (2002) view on the decomposition of stative predicates, which I take as the ground for the analysis proposed in this chapter. Then, I will introduce the division between D-states and K-states made within stative predicates, which has been suggested to account for the non-unitary behavior of different state predicates mentioned and will also be helpful to understand the diverse nature of stative predicates in Basque.

### 6.2.1. States in Hale & Keyser

Hale & Keyser (H&K onwards) (2002) argue that stativity is not a feature of heads, but that it results from the semantic combination of meaningful elements in constructions. Particularly, they claim that the semantic opposition of central vs. terminal coincidence (Hale 1986) is determinant. Several lexical items are specified with a central coincidence feature: (i) the extended projection of adjectives ( $\delta$ ) – represented as a state subevent in this dissertation–, (ii) a subgroup of adpositions; and (iii) copular verbs. Focusing on the second group of lexical items involving central coincidence, they propose that stative predicates of the kind (8) and (9) are structurally embedded with an adposition of central coincidence.

- (8) a. John feared the truth  
 b. John knew the truth  
 c. John admired the truth  
 d. John liked the truth  
 e. John respected the truth  
 (H&K 2002: 208)
- (9) a. Mary has my respect  
 (cf. I respect Mary)  
 b. She has the boss's esteem  
 (cf. The boss esteems her)  
 c. He has his children's love  
 (cf. His children love him)  
 d. Cowboys have my envy  
 (cf. I envy cowboys)  
 e. Leecil has our admiration  
 (cf. We admire Leecil)  
 (H&K 2002: 209)

The sentence with the predicates 'respect' in (8e), for example, would be paraphrased as *John got the truth (to be) with his respect*, where the central coincidence *with* (the possessive preposition) would correspond to the overt instance of the preposition which remains silent in (8e). This is illustrated in (10). The same silent preposition is posited to be embedded in *locatum* predicates like *saddle* and *water* (1993 2002 2005), indeed (consider the paraphrase, e.g. John provided the truth with his respect).

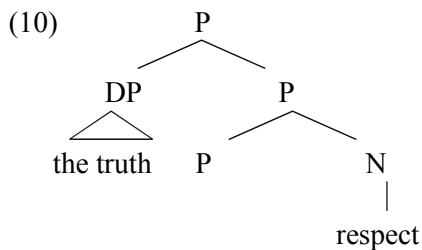

According to H&K (2002: 209), the stative predicates involving the use of *have* (9) have a similar underlying structure. The subject of the *have*-construction (*Mary* in (9a)) would correspond to the DP in (10), the object of *have* to the N object of P, and the predicate *have* to P.

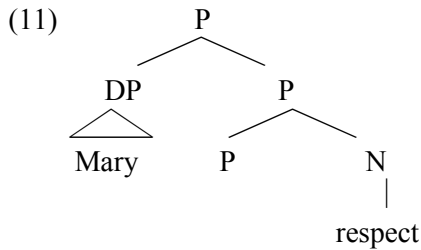

I take this analysis to be correct in two aspects: (i) in that these stative clauses are built on an element bearing a central coincidence feature; and (ii) in that *have* can be decomposed into an adposition similar to ‘with’.<sup>89</sup>

Recall from the chapters 2, 3 and 4 that H&K (1993) argue that some denominal and deadjectival eventive predicates consist of a silent V to which its overt N, P or A complement has been incorporated. The dynamic counterparts of the predicates mentioned above, illustrated in the progressive and in the imperative in (12) and combined with the predicate ‘give’ in (13), would be built in a similar fashion (14), with the difference that the P of central coincidence is further selected by V.

- (12) a. Respect your parents  
b. He is liking his new job
- (13) a. I give my respect to Mary  
b. The boss gives her his esteem

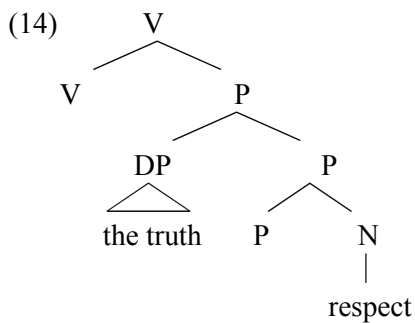

Therefore, according to H&K (2002), although predicates in both (8) and (12) have the similar surface form –e.g. *respect*), they have different underlying structures. Both of them are built by means of a conflation process of the nominal ‘respect’, but the

<sup>89</sup> Nevertheless, in chapter 7, I will argue that the central coincidence feature posited for these clauses can be decomposed into two heads (and not into a single ‘with’), one for each argument: a kind of possessive ‘with’ introducing the external argument and an inclusive ‘in’ introducing the internal one. None of them is necessarily adpositional.



dynamic, non-stative variant in (12) is further conflated onto V, and not only onto P.<sup>90</sup> Thus, according to H&K (2002), the stativity/dynamicity of these predicates lies on the P vs V category distinction of the predicates, as shown in the structures (10) and (14).

As claimed in chapter 5, I do not consider that the lexical category V exists in syntax, so that in my analysis of stative/eventive predicates, the V category does not play any role. Instead, I will claim that the projection of the *proc* head is what yields eventivity, and that stative-like properties arise due to the presence of central coincidence heads.

### 6.2.2. Two types of states

As commented previously, all stative predicates do not behave in a unitary fashion regarding the tests usually proposed in order to discriminate states from non-states. Dowty (1979) already noted that some stative predicates were perfectly grammatical when placed in the progressive, a syntactic configuration which is supposedly only compatible with non-states. Dowty (1979: 173) addresses the case of predicates like *lie, sit, stand, rest* etc., illustrated in example (7) and brought here for convenience. He terms this kind of stative predicates ‘interval statives’.

- (15) a. The socks are lying under the bed  
 b. Your glass is sitting near the edge of the table  
 c. The long box is standing on end  
 d. One corner of the piano is resting on the bottom step

Levin & Rappaport Hovav (1995) and Rappaport Hovav & Levin (2000), in turn, call them ‘verbs of spatial configuration’ and argue that they can have several different readings and that each reading has a different structure: with an inanimate subject, they are predicates of *simple position*, while with an animate subject, they are predicates of *maintaining* a position or *assuming* a position (see section 3.1. for some comments about these predicates in Basque). When they have a simple position interpretation, they necessarily require to be combined with a locative phrase. When they are predicates of maintaining a position, in contrast, they do not need such a phrase (but see Rothmayr 2009 for a more detailed analysis of the optionality of the locative adverbial in these predicates).

<sup>90</sup> Recall that, in my analysis, I do not assume that conflation takes place. Instead, I argue that a LI can be inserted in more than one syntactic node.

- (16) The statue stood in the garden  
 (17) The child stood (on the fence) (Rappaport Hovav & Levin 2000: 276)

Rappaport Hovav & Levin (2000) argue that in the former reading, these predicates are unaccusative, while in the latter, they are unergative. I will come to these predicates in the following lines, since according to Rothmayr (2009), these two subclasses of predicates of spatial configuration (which she calls ‘verbs of position’) represent actually the two classes of stative predicates that I am addressing in this section: (non-eventive) K-states and (eventive) D-states. For instance, the two subclasses of predicates of spatial configuration are closely related to their ability to occur in the progressive, as Dowty (1979: 174) notes. Predicates of simple position – those considered unaccusative in Rappaport Hovav & Levin (2000)– are ungrammatical in the progressive:

- (18) a. New Orleans lies at the mouth of Mississippi River  
 b. \*New Orleans is lying at the mouth of the Mississippi River

Before going through the difference between these two classes of state predicates, it is necessary to recapitulate the broader contrast between states and non-states. Some authors have suggested that the difference capturing the diverging behavior between them reduces to the presence or absence of an event variable. Davidson (1967) argued that action sentences (overall, those corresponding to Vendlerian activities, achievements and accomplishments) contain a special variable referring to the event denoted by the verb. He proposes the formalization in (20) for a sentence (19), with the activity predicate *butter*.

- (19) Jones buttered the toast slowly, deliberately, in the bathroom, with a knife, at midnight (Davidson 1967: 38)  
 (20)  $\exists e$  [*butter* (Jones, toast, e)  $\cap$  *deliberately*(e)  $\cap$  *in the bathroom*(e) ...]

As can be seen, the predicate *butter* contains, together with its agent and theme argument, an event argument *e*. Adverbials and locatives are related by first order predication to this argument, as shown in the logical form of the sentence. Building on the original Davidsonian idea, Parsons (1990) develops a neo-Davidsonian view according to which not only adverbials are introduced by predication on the event argument, but also the rest of the participants of the predicate, as can be seen:

- (21)  $\exists e$  [butter(e)  $\wedge$  Agent(Jones, e)  $\wedge$  Patient(toast, e)  $\wedge$  deliberately(e)  $\wedge$  in the bathroom(e) ...]

The participants of the event are related to it by means of thematic relations such as Agent and Patient. Kratzer (1994 1996) follows partly this neo-Davidsonian view and applies it to syntax, claiming that the agent and other external arguments are related to the predicate by means of secondary predication, like in Parsons' approach. In her terms, the patient or the direct object of the predicate is the only argument which is directly introduced by the predicate and not in a neo-Davidsonian fashion. This view is represented in the following formalization:

- (22)  $\exists e$  [butter(toast, e)  $\wedge$  Agent(e, Jones)  $\wedge$  deliberately(e)  $\wedge$  in the bathroom(e) ...]

Leaving aside the introduction of arguments in these theories, I will focus on which kind of predicates have been claimed to introduce an event argument like that proposed by Davidson. First, I will present the view adopted in Maienborn (2005 2007) and Rothmayr (2009), which suggest that there are actually two types of states, and then, I will concentrate on the proposal made by Fábregas & Marín (2012) which explain the properties of eventive stative verbs framed in the First Phase Syntax.

#### 6.2.2.1. D-STATES AND K-STATES: MAIENBORN (2005 2007) AND ROTHMAYR (2009)

As already mentioned, Davidson (1967) suggested that only non-states contain an event argument. Maienborn (2005 2007) shows that many stative predicates fail to pass the tests commonly used to prove the existence of an event argument. In particular, Maienborn suggests that some stative predicates contain an event variable as defined by Davidson (1967), while others do not. The former are called *Davidsonian states*, and the latter *Kimian states*, a term issued from the idea of temporally bound property exemplifications advocated by Kim (1969 1976). She assumes the following working hypothesis of Davidsonian eventualities:

- (23) Davidsonian notion of eventualities:

Eventualities are particular spatiotemporal entities with functionally integrated participants.

This way, these are the ontological properties of Davidsonian eventualities as posited in Maienborn (2005 2007):

- (24) Ontological properties of eventualities
- a. Eventualities are perceptible.
  - b. Eventualities can be located in space and time.
  - c. Eventualities can vary in the way that they are realized.

From these properties, these linguistic diagnostics follow:

- (25) Linguistic diagnostics for eventualities
- a. Eventuality expressions can serve as infinitival complements of perception verbs
  - b. Eventuality expressions combine with locative and temporal modifiers.
  - c. Eventuality expressions combine with manner adverbials, instrumentals, comitatives, etc.

In contrast, Kimian states are defined this way:

- (26) Kimian states:

K-states are abstract objects for the exemplification of a property P at a holder x at a time t.

From this definition, Maienborn proposes that Kimian states have the following properties and linguistic diagnostics:

- (27) Ontological properties of Kimian states:
- a. K-states are not accessible to direct perception and have no location in space.
  - b. K-states are accessible to (higher) cognitive operations.
  - c. K-states can be located in time.
- (28) Linguistic diagnostics for Kimian states:
- a. K-state expressions cannot serve as infinitival complements of perception verbs and do not combine with locative modifiers.
  - b. K-state expressions are accessible for anaphoric reference.
  - c. K-state expressions combine with temporal modifiers.

Maienborn proposes that certain predicates broadly considered stative have the properties stated in (24) and behave as in (25) in the syntactic diagnostics. As a consequence, she argues that those stative predicates are actually Davidsonian

eventualities and, thus, terms them D-states. Other stative predicates, in contrast, have the properties of (27) and show the distribution in (28). She considers these stative predicates K(imian)-states. These are some of the predicates she lists:

- (29) D-states  
sit, stand, lie, gleam, glow, bubble, sleep, wait, shine, whistle, creak, kneel, shimmer
- (30) K-states  
weigh, know, resemble, own, hate, be, have

Maienborn shows that predicates like *stand*, *wait* and *sleep* contrast with predicates like *weigh* and *know* in the linguistic contexts stated above. In the following examples, I show some German data presented in Maienborn (2005: 7), involving the use of the predicates as infinitival complements of perception predicates.

- (31) a. \*Ich sah die Tomaten 1 Kg wiegen  
I saw tomatos 1kg weigh  
b. \*Ich hörte Carol die Antwort wissen  
I heard Carol the answer know
- (32) a. Ich sah Carol am Fenster stehen  
I saw Carol at.the window stand  
b. Ich hörte Carol warten / schlafen  
I heard Carol wait / sleep

As can be seen in the examples, predicates like *stand*, *wait* and *sleep* pattern with eventive predicates, being grammatical as infinitives of perception predicates. Similarly, *wait* and *sleep* are perfectly grammatical with locative modifiers, while *weigh* and *know* are ungrammatical (Maienborn 2007: 4):

- (33) a. \*Die Tomaten wiegen neben den Paprikas 1 Kg  
The tomatoes weigh besides the paprikas 1kg  
b. \*Bardo weiß (gerade) dort drüben die Antwort  
Bardo knows (at-this-moment) over there the answer
- (34) a. Das Auto wartet an der Ampel  
The car waits an the traffic light  
b. Bardo schläft in der Hängematte  
Bardo sleeps in the hammock

Maienborn suggests that the contrastive behavior found in these non-dynamic predicates is captured in terms of presence or absence of a Davidsonian event

argument. Non-dynamic predicates which pattern with eventive predicates in the diagnostics mentioned are Davidsonian eventualities; D-states. In contrast, those which behave differently (ungrammatical as infinitives on perception predicates, with locative modifiers and in other linguistic contexts reserved to eventive predicates) are Kimian (K-) states.

Basing on this distinction, Rothmayr (2009) provides an analysis of several classes of non-dynamic predicates in German, applying many syntactic tests and proposing a syntactic structure for each class of stative predicate. She argues that stative predicates do not form a uniform class and that they can have complex structures as well. They may be eventive or Kimian depending on the aspectual operators present in the structure. She shows that there exists a great variety of stative verbs and that the Kimian reading emerges when neither the operator DO nor BECOME are present in the structure.<sup>91</sup> Thus, according to her, the presence of DO and BECOME are the basic determinants of eventivity.

As examples, the posture predicates mentioned above contain according to her the DO operator, in contrast to simple position predicates which do not. This is because in posture predicates, an animate entity holds its body in a particular position deliberately –as suggested in Rappaport Hovav & Levin (2000)– and, therefore, they are more similar to activities in this sense.

- (35) Der Poldi hockt am Boden  
The Poldi crouches on the floor  
'Poldi is crouching in the floor'

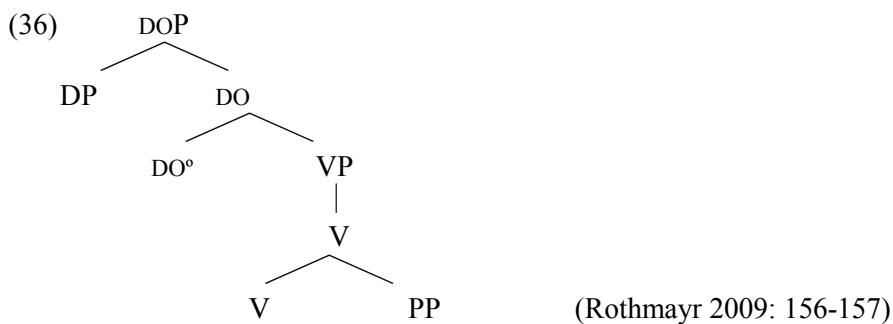

In contrast, predicates of simple position do not denote an action that is deliberately carried out by the subject, but just that an argument is located at a particular position

<sup>91</sup> In Rothmayr (2009), there is another aspectual operator which does not trigger an eventive interpretation: CAUSE. Thus, stative predicates can consist of this operator and have a complex structure, without that implying an eventive reading.

in space. The locative PP is thus an argument of V and no aspectual operator is present.

- (37) Das Buck liegt am Tisch  
 The book lies on-the table  
 ‘The book is lying on the table’

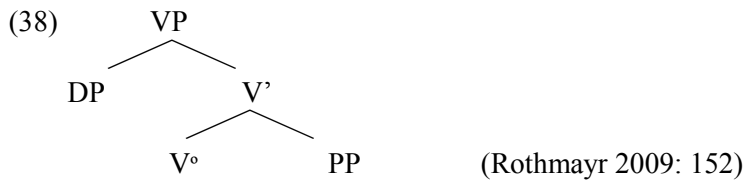

Since posture predicates contain the DO operator, they are eventive. In contrast, predicates of simple position do not project DO, so that they have a Kimian interpretation.

Fábregas & Marín (to appear) also argue, in the same line of analysis, that some “stative”, non-dynamic predicates can be eventive and have an event argument. They base their analysis on the *First Phase Syntax* decomposition of predicates (Ramchand 2008a). According to Fábregas & Marín, the subeventive head responsible for the emergence of eventivity is *proc*.

Departing from Ramchand, Fábregas and Marín propose that the head Process is not necessarily the heart of the dynamic predicate (see also chapter 2 and chapter 4). According to them, it introduces the event argument –thus, it supplies the predicate with eventivity– but its dynamic nature depends on the type of complement it selects for: if it selects for a PATH argument it will be dynamic, whereas if it selects for a central coincidence P, it will be non-dynamic and behave as a D-state. In section 6.3.1, I will consider this proposal in the light of Basque data. As mentioned in chapter 2 and chapter 4, I consider that *proc* can select for a non-dynamic Rheme, that is to say, a Rheme which is associated with an [–incremental] and [–transitional] measure. The selection of a non-dynamic Rheme by *proc* yields a non-dynamic event, an event where the time goes on but there is no progression. Basing on this, I will argue that non-dynamic eventive predicates are D-states, in the sense that they behave like stative predicates in certain contexts, particularly when selected by an adposition of central coincidence.

Now, I will focus on the syntactic tests they use to show the existence of D-state predicates in Spanish, and in section 6.3.1, I will apply them to Basque.

## 6.2.2.2. D-STATES IN FÁBREGAS &amp; MARÍN (2012)

Fábregas & Marín (2012: 5) present a group of Spanish predicates which, additionally to those pointed out by Maienborn (2005 2007), have properties belonging to both activities and states.

- (39) *gobernar* ‘to govern’, *dirigir* ‘to direct’, *presidir* ‘to head’, *habitar* ‘to inhabit’, *coordinar* ‘to coordinate’, *controlar* ‘to control’, *supervisar* ‘to supervise’, *mantener* ‘to maintain’, *sostener* ‘to support’.

By means of the diagnostics proposed in Maienborn (2005 2007) and some others, they show that these Spanish predicates pattern in some contexts with activities and in others with states. The predicates above differ from activities in five diagnostics. The first one involves the conceptual meaning associated with the predicates: these verbs represent homogenous predicates (Rothstein 2004) which satisfy the subinterval property. They do not convey a change of any sort.

- (40) P has the subinterval property iff (Katz 2003: 218)

$$\text{If } P(t)=1 \text{ then } \forall t' \subseteq t \rightarrow P(t')=1$$

Activities do also fulfill the subinterval property (Benett & Partee 1972), but according to Maienborn (2005: fn. 4) while they “involve a lower bound on the size of subintervals that are of the same type, states have no such lower bound –i.e., they also hold at atomic times”. According to Maienborn, D-states pattern with states in this sense.<sup>92</sup> Secondly, they have a non-habitual meaning in the present tense, like states such as *saber* ‘to know’ and unlike non-states like *escribir* ‘to write’<sup>93</sup> (Dowty 1979) (41). Thirdly, they do not combine with ‘slowly’ or ‘gradually’ (42), and finally, they cannot be the complement of the verb *parar* ‘to stop’, once again patterning with states and contrasting with dynamic verbs (Dowty 1979) (43). Some examples have been taken from Fábregas & Marín (to appear) and others are mine.

- (41) a. Esteban escribe (F&M: 4)  
Esteban writes

*Habitual reading*

<sup>92</sup> Recall that, in chapter 2, having a lower bound was represented in the graphics of the measures as a transition from a negative phase to a positive one near  $p(0)$ . As I have argued in chapter 4, sec. 4.2.1.4, non-dynamic Rhemes are associated to measures with no lower bound.

<sup>93</sup> Non-states like *escribir* ‘to write’ have a habitual reading in an out of the blue context. Additionally, they can also have an on-going interpretation in a narrative context. In this chapter, I am not considering the on-going reading because it is not relevant for the discussion, but see chapter 7.



- b. Fertuoso dirige esta empresa (F&M: 6) *Non-habitual reading*  
 Fertuoso rules this company
- c. Juan sabe la respuesta *Non-habitual Reading*  
 John knows the answer
- (42) a. Esteban pasea lentamente (F&M: 3)  
 Esteban walks slowly
- b. \*Fertuoso ha dirigido esta empresa lentamente (F&M: 6)  
 Fertuoso has ruled this company slowly
- c. \*Juan sabe la respuesta lentamente  
 John knows the answer slowly
- (43) a. Esteban ha parado de correr (F&M: 3)  
 Esteban has stopped of run
- b. \*Fertuoso ha parado de dirigir la empresa (F&M: 6)  
 Esteban has stopped of rule the company
- c. \*Juan ha parado de saber la respuesta  
 John has stopped of know the answer

There is another test which Maienborn (2005 2007) uses to prove that D-states do not behave as common process predicates: that they cannot be the anaphoric reference of ‘this happened’. Nevertheless, as Fábregas & Marín show, this test does not always give the expected results, since some Spanish D-states can actually be the anaphoric reference of ‘this happened’.

- (44) A. La lámpara brillaba intensamente.  
 The lamp shined intensely
- B. Esto sucedía mientras... (F&M: 3)  
 This happened while...
- (45) A. Esteban gobernó esta nación durante varios años.  
 Esteban ruled this nation for several years
- B. Esto sucedió mientras... (F&M: 5)  
 This happened while...

On the other hand, the predicates listed in (39) behave like activities and contrast with statives in other four contexts. Firstly, since D-states are posited to contain a Davidsonian event argument and Davidsonian eventualities are spatiotemporal entities, they can be perceived. Thus, D-states can be the infinitival complements of perception predicates. The predicates proposed by Fábregas & Marín (2012), for example *gobernar* ‘govern’, can serve as the infinitive of the predicate *ver* ‘to see’, like the dynamic activity *bailar* ‘to dance’ and unlike the stative *saber* ‘to know’ (46). Secondly, they combine with locative and temporal modifiers (47), patterning with *bailar* ‘to dance’ and contrasting with *conocer* ‘to know’. Thirdly, they are compatible with manner adverbials such as *ordenadamente* ‘orderly’ (48), like *bailar* ‘dance’ and unlike *poseer* ‘to own’. Finally, they get optionally a time span reading or a degree

reading with the adverb *un poco* ‘a little’ (48), contrary to statives like *parecer* ‘resemble’, which can only get a degree reading (Maienborn 2005, Rothmayr 2009).

- (46) a. Yo vi bailar a Juan  
I saw dance to Juan  
b. Los ciudadanos vieron a Zapatero gobernar España con auténtico terror  
The citizens saw to Zapatero rule Spain with sheer panic  
(F&M: 7)  
d. \*Yo vi conocer la dirección a Juan  
I saw know the address to Juan
- (47) a. Juan baila en el jardín  
John dances in the garden  
b. Gerineldo dirige la empresa en su casa (F&M: 6)  
Gerineldo rules the company in his house  
c. \*Eustaquia conoce la dirección en el jardín (F&M: 6)  
Eustaquia knows the address in the garden
- (48) a. Juan baila ordenadamente  
John dances orderly  
b. Gerineldo gobierna España ordenadamente (F&M: 6)  
Gerineldo rules Spain orderly  
c. \*Eustaquia posee casas ordenadamente (F&M: 6)  
Eustaquia owns houses orderly
- (49) a. Juan bailó un poco *Temporal reading*  
John dances a little  
b. Gerineldo dirigió un poco las obras (F&M: 7) *Temporal and degree reading*  
Gerineldo rules a little the working  
c. Eustaquia se parecía un poco a su madre (F&M: 7) *Degree reading*  
Eustaquia SE resembled a little to her mother

These results are summarized in the following table (mostly from F&M (p.5) but without including the diagnostic of being the anaphoric reference of ‘this happened’):

**Table 6.1.** Comparison of the aspectual behavior between Process verbs, D-states and K-states

|                                            | Process verbs<br>(e.g. <i>bailar</i><br>'dance') | D-states<br>(e.g. <i>gobernar</i><br>'govern') | K-states<br>(e.g. <i>saber</i><br>'know') |
|--------------------------------------------|--------------------------------------------------|------------------------------------------------|-------------------------------------------|
| subinterval property                       | –                                                | +                                              | +                                         |
| complement of stop                         | +                                                | –                                              | –                                         |
| compatibility with slowly or gradually     | +                                                | –                                              | –                                         |
| habitual reading in present tense          | +                                                | –                                              | –                                         |
| infinitival complement of perception verbs | +                                                | +                                              | –                                         |
| event-related manner adverbial             | +                                                | +                                              | –                                         |
| event-related place adverbial              | +                                                | +                                              | –                                         |
| time-span reading with a little            | +                                                | +                                              | –                                         |

According to Fábregas & Marin, the differences between processes and D-states are captured in terms of dynamicity. Since D-states are non-dynamic, they do not denote any change and they are strictly homogenous. That is why they have a non-habitual reading in the present tense. Additionally, it also explains why D-states get a similar meaning in present tense and within the progressive.<sup>94</sup>

- (50) a. Juan duerme  
Juan sleeps  
b. Juan está durmiendo  
Juan is sleeping
- (51) a. La lámpara brilla intensamente  
The lamp shines intensely  
b. La lámpara está brillando intensamente  
The lamp is shining intensely

On the other hand, the fact that D-states can be put within a progressive is in itself a remarkable fact, given that stative predicates are supposedly incompatible with it (Vendler 1957/1967). If the progressive needs to be combined with a predicate projecting a Davidsonian event argument, the contrast between D-states and K-states in this context is explained. The progressive is compatible with D-states because they

<sup>94</sup> See chapter 8 for a similar consideration for Basque. It is also going to be addressed in section 6.3.1.

involve an event argument, and is incompatible with K-states because K-states do not have one. Locatives and manner adverbials are anchored to the event and this is why D-states can combine with such modifiers, unlike K-states. Additionally, the different readings obtained with the modifier *a little* are also resolved with this analysis. *A little* has temporal value with D-states because Davidsonian eventualities introduce temporal information into the predicate. *A little* modifies the temporal duration proportioned by it.

Summing up, Fábregas & Marín (2012) propose that eventivity must be disassociated from dynamicity and that this way the non-uniform behavior of stative predicates can be explained. As I have presented in this section, this has been a long standing problem for the aspectual classification predicates and the diagnostics proposed since Vendler (1957/1967). The approach put forward by Maienborn (2005 2007) and followed by Rothmayr (2009) and Fábregas & Marín (2012) offers a good explanation for this old puzzle.

### 6.3. SUBVEVENTIVE DECOMPOSITION OF STATES

In this section, I will apply the tests reviewed so far to Basque data and I will show that in Basque there are also some predicates which behave in some contexts like activities and like stative in others. I will propose, following Fábregas & Marín (2012) that this is due to the fact that these predicates have a process subevent, to their lack of dynamicity and to the presence of a central coincidence adposition. Departing from them, I will claim that the lack of dynamicity comes from the Rheme selected by *proc*, and that the central coincidence adposition involved in D-states actually corresponds to viewpoint aspect.

#### 6.3.1. D-states and K-states in Basque

The D-states listed by Maienborn (2005 2007) are mostly unergative, but many of them cannot be translated into Basque by means of simple or complex unergative predicates, but only through copular predicates plus other material or by means of verbal periphrases. On the other hand, those presented in Fábregas & Marín can be translated easier to Basque, most of them in the form of loan predicates. In contrast to the predicates pointed out by Maienborn (2005), the latter predicates are mostly transitive.

(52) Some Basque D-states

a. simple unergative/transitive predicates

*distiratu* ‘to gleam, to glow’, *itxaron* ‘to wait’, *gobernatu* ‘to govern’,  
*zuzendu* ‘to direct’, *koordinatu* ‘to coordinate’, *mantendu* ‘to maintain’,  
*kontrolatu* ‘to control’, *eutsi* ‘to maintain’, *gainbegiratu* ‘to supervise’,  
*errespetatu* ‘to respect’, *eskertu* ‘to thank’, *erreinatu* ‘to reign’

b. complex unergative predicates

*lo egin* ‘to sleep’, *argi egin* ‘to gleam, to shine’, *dirdira egin* ‘to glow’,  
*kirrinka egin* ‘to creak’.

As can be seen, the predicate *inhabit*, pointed out by Fábregas & Marín too, has not been listed, since in Basque it has the form of a bare analytic predicate and it is closer to a K-state rather than to a D-state. Similarly, the predicates of position (in Rothmayr’s terms) or predicates of spatial configuration (in Levin & Rappaport Hovav’s terms) have not been included in the list. This is because the meaning of

these predicates falling within D-states is expressed in Basque by means of copular verbs.

As Rappaport Hovav & Levin (2000: 278-279) show, some predicates of spatial configuration are ambiguous between a (stative) *maintain* reading (posture verbs in Rothmayr 2009) and an (eventive) *assume* reading. The former interpretation corresponds to the D-state kind I am analyzing in this section, while the latter involves a dynamic change of position.

- (53) a. An ex-president stood on this platform                     *Maintain* /  *Assume*  
 b. The Queen's children sat on those chairs

If we want to translate into Basque these two readings of English spatial configuration predicates, two different types of structures are necessary. For the *maintain* reading, the locative copula in its synthetic form is required, together with a predicative form such as a *-tua* or *-tuta* participle (e.g. *eseria/eserita* 'sitted') or an adverb (e.g. *zutik* 'standing',<sup>95</sup> *belauniko* 'kneeling').

- (54) a. Lehendakari            ohia zutik zegoen plataforma gainean             *Maintain*  
 president former.ABS standing was platform top-INE  
 'The former president was standing on the platform'  
 b. Erregina-ren umeak            eserita zeuden aulki hori-etan  
 Queen-GEN children.ABS sitting were chair those-INE  
 'The Queen's children were sitting in those chairs'

In order to convey the dynamic assume reading, in contrast, the *-tu* analytic form is used instead.

- (55) a. Lehendakari ohia            plataforma gain-ean zutitu            zen             *Assume*  
 president former.ABS platform top-INE standing-TU be.3sgABS.PST  
 'The former president stand up in the platform'  
 b. Erregina-ren umeak            aulki hori-etan eser-i ziren  
 Queen-GEN children.ABS chair those-INE sit-TU be.3plABS  
 'The Queen's children sat in those chairs'

As I will show later, the *-tzen* analytic form of some predicates is the only configuration giving rise to a D-state kind. Nevertheless, in the case of these predicates of position, it is not possible to obtain a *maintain* reading with the *-tzen*

<sup>95</sup> The adverb *zutik* is headed by the partitive *-rik*, a morpheme used in the formation of adverbs (*zutunik* 'standing', *bilutsik* 'naked', *oimutsik* 'barefoot', *isilik* 'quiet, quietly', *bakarrik* 'alone' etc.) and also in the formation of participles (*jausirik* 'fallen', *etorririk* 'come').

analytic form. When these predicates are put in a *-tzen* analytic configuration (56), a habitual reading is conveyed. Even in a narrative context (57), these predicates would not result in a *maintain* reading. In such a case, they would give rise to an on-going reading.

- (56) a. Lehendakari ohia      plataforma gainean zuti-tze-n      zen      *Habitual*  
 president      former.ABS platform      top-INE standing-TZE-INE be.3sgABS.PST  
 ‘The former president used to stand in this platform’
- b. Erregina-ren umeak      aulki hauetan      eseri-tze-n ziren      *Habitual*  
 Queen-GEN children.ABS chair those-INE sit-TZE-INE be.3plABS  
 ‘The Queen’s childre used to sit in those chairs’
- (57) a. Lehendakaria      zutitzen      da      [eta esaten dio bere idazkariari...]  
 president.ABS standing-TZE-INE be.3sgABS [and says to his secretary...]      *On-going*  
 ‘The president stands up and says to his secretary...’
- b. Umeak      eseri-tze-n dira      [eta goxokiak jaten hasten dira]      *On-going*  
 children.ABS sit-TZE-INE be.3plABS [and start eating candies...]  
 ‘The children sit and start eating candies...’

Thus, predicates of *maintaining a position* cannot be considered to be D-states in Basque.<sup>96</sup>

<sup>96</sup> Some weather predicates like *euria egin* ‘to rain’ and *elurra egin* ‘to snow’ (mentioned in section 4.3.1) must be regarded as D-states. Others, in contrast, (e.g. *bero egin* ‘to be warm’, *hotz egin* ‘to be cold’) seem to be closer to K-states. That would be problematic for the analysis made in chapter 3 about the light predicate *egin*. In chapter 4, I claimed that *egin* spells out the [<sub>procP</sub> proc] node, so that *egin* must always occur in eventive predicates.

Nevertheless, *egin* weather predicates and weather predicates in general are quite special in several aspects. They have certain properties which differentiate them from the rest of Basque predicates. For example, in central and western varieties of Basque, morphologically simple weather predicates generally need to be combined with *\*edun* ‘have’ auxiliary, although they convey a transition, and as in complex weather predicates, there cannot take an overt subject.

- (xv) Arratsalde hartan goiz ilun-du zuen      [F.Rey (H. McCoy), 2010: 113]  
 afternoon that-INE early dark-TU have.3sgERG.PST  
 ‘In that afternoon, it got dark very early’

- (xvi) San Fermin biharamunean, 6 graduraino hoztu zuen      [P.Zabala 2000: 268]  
 Saint fermin day-after-INE, 6 grade-TERM cold-TU have.3sgERG.PST  
 ‘The day after San Fermin, the temperature went down to 6 grades’

The necessity to occur with *\*edun* ‘have’ auxiliary is even present with the *ari* progressive, which always takes *izan* ‘be’ auxiliary in these dialects.

- (xvii) Hozten ari du kanpoalde-an      [M.Larrañaga (D.Parker), 2005: 236]  
 Cold-TU PROG have.3sgERG outside-INE  
 ‘It is cooling outside’

*Egin* weather predicates like *elurra egin* ‘to snow’ cannot be directly combined with the *ari* progressive. As a matter of fact, there is not a single example of *elurra egin* ‘to snow’ and *euria egin* ‘to rain’ followed by *ari* in the *Contemporary Reference Prose* corpus (Sarasola et al. 2011). In contrast, there are plenty of examples where *ari* appears directly combined with the Root, without the use of *egin* ‘do’:

- (xviii) Bilbon elurra ari zuen      mara-mara      [Berria, 2006-01-29]  
 Bilbo-INE snow PROG have.3sgERG softly  
 ‘In Bilbao, it is snowing softly’

Let us list now the Basque translations of the most cited K-states, classified according to their verbal configuration:

(58) Some Basque K-states

a. predicates in their synthetic form

*etzan* ‘to lie’, *jakin* ‘to know’, *eduki* ‘to have’

b. predicates in the *-tzen* analytic form

*pisatu* ‘to weigh’, *ezagutu* ‘to know’, *gorrotatu* ‘to hate’

b. bare analytic predicates

*antza izan* ‘to resemble’, *gorroto izan* ‘to hate’, *balio izan* ‘to cost, to be worth’

K-states can appear in three different forms in Basque: some K-states which have a synthetic form occur in the synthetic configuration; others take the *-tzen* analytic configuration; and, finally, other K-states appear in the bare analytic configuration (see section 3.3 about bare analytic predicates).

### 6.3.2. Syntactic diagnostics of dynamicity and eventivity in Basque

Now that I have listed the most cited D- and K-states in Basque, let us see how they behave in the tests used to determine their D- or K-state status. I will begin firstly with the diagnostics distinguishing D-states from activities. As I mentioned earlier, on the one hand, there is a conceptual difference between these two groups of predicates. D-states obey the subinterval property at atomic times (Maienborn 2005): if the predicate is true at an interval I, it is true at all subintervals of I. I argue that predicates

- 
- (xix) Euria ari du kanpoan [Berria, I. Rozas, 2006-03-26]  
 rain PROG have.3sgERG.PST outside-INE  
 ‘It is raining outside’

This is an impossible scenario in, e.g. other *egin* unergatives. For instance, taking as an example another predicate like *dir-dir egin* ‘to shine’, *ari* cannot combine with the Root, but instead, it has to select for the whole Root+*egin*.

- (xx) \*Dir-dir ari du  
 shine PROG have.3sgERG  
 (xxi) Dir-dir egi-te-n ari da  
 shine do-TZE-INE PROG be.3sgABS  
 ‘It is shining’

As can be seen, weather predicates represent a challenge, not only to derive the eventive properties of *egin*, but also to account for the absence of the subject, the selection of the auxiliary, and even for *ari*, which surprisingly can select directly a Root in weather predicates. For all these reasons, and because it would be out of the scope of this dissertation, I leave the analysis of weather predicates for further research.



like *distiratu* ‘to shine’ obey the subinterval property because their Root is associated with a [–incremental] and [–transitional] measure. As pointed out by Maienborn (2005), activities like *sing* also obey the subinterval property, but, unlike D-states, their measure does have a lower bound: for a point to be located in the denotation of  $\llbracket \textit{sing} \rrbracket$ , there has to be a minimal progression (e.g. concatenation of two or more vocalized notes). I repeat here the graphic representations of *distira* ‘shine’ and *kanta* ‘song’, as depicted in chapter 4 (sec. 4.3.1):

(59) *kanta*(p)

$$\begin{array}{ccccccc} - & + & + & + & + & + & \\ 0 & & & & & & 1 \end{array}$$

(60) *distira*(p)

$$\begin{array}{ccccccc} + & + & + & + & + & + & + \\ 0 & & & & & & 1 \end{array}$$

The lower bound of *kanta*(p) is represented by the transition from the negative phase to a positive phase. In the measure denoted by *distira*(p), since all points fall within the denotation of  $\llbracket \textit{distira} \rrbracket$ , there is not a lower bound.

On the other hand, there are three syntactic contexts in which D-states and process predicates behave differently: (i) the compatibility with ‘stop’; (ii) the compatibility with adverbs such as ‘slowly’ or ‘little by little’; and (iii) their habitual/non-habitual reading in the present tense (Dowty 1979).

The first test mentioned –the compatibility with ‘stop’– cannot be applied to Basque, because, in that context, the verb *utzi* ‘to give up’ is used and *utzi* ‘to give up’ is compatible with many kinds of predicates: activities (61), more static like activities (62), and even with predicative constructions consisting of a copula (63):

- (61) Mikelek erretzeari utzi dio  
 Michael-ERG smoke-TZE-DET-DAT give-up have.3sgERG.3sgDAT  
 ‘Michael has given up smoking’
- (62) Popular bankua gida-tze-a-ri utzi dio Luis Valls[ek]  
 Popular bank.ABS rule-TZE-DET-DAT give-up have.3sgERG.3sgDAT Luis Valls-ERG  
 ‘Luis Valls has ceased to rule the Popular Bank’ [Berria, 2004-10-21]
- (63) Andy Roddick-en entrenatzailea iza-te-a-ri utzi dio  
 Andy Roddick-GEN coach be-TZE-DET-DAT give-up have.3sgERG.3sgDAT  
 Brad Gilbert-ek  
 Brad Gilbert-ERG  
 ‘Brad Gilbert has ceased to be Andy Roddick’s coach’ [Berria, 2004-12-15]

Thus, the compatibility with *utzi* ‘to give up’ cannot be considered an appropriate diagnostic to differentiate activities from D-states, as *give up* is not in English.<sup>97</sup> Nevertheless, the compatibility with the aspectual verb *bukatu/amaitu* ‘to finish’ can be taken as a good test (also mentioned in Dowty 1979: 57, in order to differentiate activities and accomplishments). *Bukatu/amaitu* ‘finish’ is compatible with accomplishments but it is incompatible with canonical stative predicates like ‘know’ and ‘resemble’.

- (64) a. Irati-k fandangoa dantza-tze-n buka-tu du  
 Irati-ERG fandango.ABS dance-TZE-INE finish-TU have.3sgERG  
 ‘Irati has finished dancing the fandango’  
 b. Jon-ek gutuna idaz-te-n buka-tu du  
 John-ERG letter.ABS write-TZE-INE finish-TU have.3sgERG  
 ‘John has finished writing the letter’  
 c. Langileek etxea eraiki-tze-n amai-tu dute  
 workers-ERG house.ABS build-TZE-INE finish-TU have.3plERG  
 ‘Irati has finished dancing the fandango’  
 d. #Miren-ek erantzuna jaki-te-n buka-tu du  
 Mary-ERG answer.ABS know-TZE-INE finish-TU have.3sgERG  
 ‘Mary has finished knowing the answer’  
 e. #Jon-ek Mikel ezagu-tze-n buka-tu du  
 John-ERG Michael.ABS know-TZE-INE finish-TU have.3sgERG  
 ‘John has finished knowing John’  
 f. #Amets-ek ama-ren antza iza-te-n bukatu du<sup>98</sup>  
 Amets-ERG mother-GEN resemblance.ABS be-TZE-INE finish-TU have.3sgERG  
 ‘Amets has finished resembling his mother’

It seems that *bukatu/amaitu* is only compatible with a dynamic eventuality entailing a bounded progression. Using the properties of the measures defined in this dissertation, predicates compatible with *bukatu/amaitu* would have a PATH associated to an [+incremental] and [+upper bound] measure. It is therefore quite deviant with achievements too (Dowty 1979: 59):

- (65) a. ?#Irati-k gailurr-era iris-te-n buka-tu du  
 Irati-ERG summit-ALL arrive-TZE-INE finish-TU have.3sgERG  
 ‘?Irati has finished arriving at the summit’

<sup>97</sup> Doing a search in Google, it seems that give up is fine with either stative predicates like *own*, copulas like *be* and activities like *dance*.

(xxii) In October, I gave up owning a car, probably forever

(xxiii) How I gave up being grumpy

(xxiv) I gave up dancing when my mum passed away

<sup>98</sup> Many of these sentences are grammatical with other meaning, though: the reading where the subject ends up as the holder of the property denoted by the predicate.

- b. ?#Irati-k etxera etor-tze-n buka-tu du  
 Irati-ERG house-ALL come-TZE-INE finish-TU have.3sgERG  
 ‘?Irati has finished coming home’

Applying it to the predicates listed in (52), it can be observed that most of them are not suitable complements of *bukatu/amaitu*, a fact which shows that these verbs are not similar to activities.

- (66) a. \*Izarr-ek distira-tze-n buka-tu dute  
 stars-ERG shine-TZE-INE finish-TU have.3plERG  
 ‘Stars have finished shining’  
 b. ?\*[Hauteskundeak galdu ostean], PP-k Madril goberna-tze-n buka-tu  
 [After losing the elections], PP-ERG Madril.abs rule-TZE-INE finish-TU  
 du  
 have.3plERG  
 ‘?After losing the elections, the PP has finished ruling Madrid’  
 c. ?\*Miren-ek enpresa zuzen-tze-n buka-tu du  
 Mary-ERG company.ABS rule-TZE-INE finish-TU have.3sgERG  
 ‘?Mary has finished ruling the company’  
 d. \*Irati-k Mikel-i itxaro-te-n amai-tu du  
 Irati-ERG Michael-DAT wait-TZE-INE finish-TU have.3sgERG  
 ‘?Mary has finished waiting for Michael’  
 e. \*Amets-ek lo egi-te-n buka-tu du  
 Amets-ERG sleep do-TZE-INE finish-TU have.3sgERG  
 ‘?Amets has finished sleeping’

The predicate *gainbegiratu* ‘supervise’ seems to accept better its combination with ‘finish’, a diagnostic which shows that *gainbegiratu* has a dynamic meaning associated with it.

- (67) Irakasleak azterketa gainbegira-tze-n buka-tu du  
 teacher-ERG exam.ABS supervise-TZE-INE finish-TU have.3sgERG  
 ‘The teacher has finished supervising the exam’

The other two syntactic tests mentioned and analyzed in Spanish predicates by Fábregas & Marín (2012) can be applied to Basque: the compatibility with ‘slowly’ or ‘gradually’ and the habitual/non-habitual interpretation obtained in the present tense. As can be seen in the examples, they are overall incompatible with the adverb *poliki-poliki* ‘slowly’, contrary to the activity *dantzatu* ‘dance’, showing that these predicates are not dynamic.

- (68) a. Ane-k poliki-poliki dantza-tze-n du  
 Ane-ERG slowly dance-TZE-INE have.3sgERG  
 ‘Ane dances slowly’

- b. \*Eguzkia-k poliki-poliki distira-tze-n du  
 sun-ERG slowly shine-TZE-INE have.3sgERG  
 ‘The sun shines slowly’
- c. \*Mikele-k Miren-i itxaro-te-n dio poliki-poliki  
 Michael-ERG Mary-DAT wait-TZE-INE have.3sgERG.3sgDAT slowly  
 ‘\*Michael waits for Mary slowly’
- d. \*Miren-ek empresa zuzen-tze-n du poliki-poliki  
 Mary-ERG company.ABS rule-TZE-INE have.3sgERG.3sgABS slowly  
 ‘\*Mary rules the company slowly’
- f. \*Jon-ek poliki-poliki lo egi-te-n du  
 John-ERG slowly sleep do-TZE-INE have.3sgERG  
 ‘John sleeps slowly’

Nevertheless, some of the predicates (*gainbegiratu* ‘to supervise’ and *koordinatu* ‘to coordinate’), are compatible with *poliki-poliki* ‘slowly’, and even better with *apurka-apurka* ‘gradually’ in certain contexts.

- (69) Irakaslea-k ikasle-en lanak gainbegira-tze-n ditu poliki-poliki  
 teacher-ERG students-GEN works.ABS supervise-TZE-INE have.3sgERG.3plABS slowly  
 ‘The teacher supervises students’ works slowly’
- (70) Irakaslea-k apurka-apurka/poliki-poliki gainbegira-tu du  
 teacher-ERG little by little slowly supervise-TU have.3sgERG.3sgABS  
 idazlana  
 essay.ABS  
 ‘The teacher has supervised the essay little by little/ slowly’
- (71) Miren-ek apurka-apurka langile guztiak koordina-tu ditu  
 Mary-ERG little by little worker all.ABS coordinate-TU have.3sgERG.3plABS  
 ‘Miren has coordinated all the workers little by little’

I believe that in these contexts, the predicates are being used with a dynamic meaning. Their direct objects behave like incremental themes: they are PATH complements measuring the process denoted by the predicate. Thus, it seems that, at least in the case of *koordinatu* ‘coordinate’, these predicates are ambiguous between a static and a dynamic reading. *Gainbegiratu* ‘to supervise’, in contrast, seems to fit better with activities. It is interesting to note that the dynamic meaning becomes the only possible interpretation if the predicates are headed by *-tu* (70-71). I will come back to the relevance of the *-tu* suffix in the following lines.

Regarding the behavior of K-states in this syntactic context, they clearly pattern with most D-states in not being able to combine with ‘slowly’ or ‘gradually’:

- (72) a. \*Mikel-ek erantzuna daki poliki-poliki/apurka-apurka  
 Michael-ERG answer.ABS knows slowly /little by little  
 ‘\*Michael knows the answer slowly/little by little’

- b. \*Gure ahulezia horr-etan datza poliki-poliki/apurka-apurka  
 our weakness.ABS this-INE lies slowly /little by little  
 ‘\*Our weakness lies in that slowly/little by little’
- c. \*Ametse-k 12 kg pisatzen du  
 Amets-ERG 12 kg weigh-TZE-INE have.3sgERG.3sgABS  
 poliki-poliki/apurka-apurka  
 slowly/little by little  
 ‘\*Amets weighs 12 kg slowly/little by little’

With respect to the last syntactic test –the habitual/non-habitual interpretation of these predicates in the Basque “present tense”– the predicates listed show a mixed behavior. The parallel in Basque of the English or Spanish present tense is the synthetic configuration in those predicates having it, and the *-tzen* analytic configuration in the rest. None of the D-states listed have an available synthetic form nowadays, so that they are aligned in the *-tzen* analytic form. Some of them can be non-habitual in this configuration, such as *distiratu* ‘to gleam’, *gobernatu* ‘to govern’, *dirdira egin* ‘to shine, gleam’ and *eutsi* ‘to maintain’. Others, in contrast, necessarily force a habitual interpretation, like *lo egin* ‘sleep’ and *itxaron* ‘wait’.<sup>99</sup>

- (73) a. Irati-k fandangoa dantza-tze-n du *Habitual*  
 Irati-ERG fandango.ABS dance-TZE-INE have.3sgERG.3sgABS  
 ‘Irati dances the fandango’
- b. Eguzkia-k distira-tze-n du *Non-habitual*  
 sun-ERG shine-TZE-INE have.3sgERG  
 ‘The sun shines’
- c. [1936an irabazi zutenek] goberna-tze-n dute *Non-habitual*  
 [those who won in 1936] rule-TZE-INE have.3plERG  
 ‘The who won in 1936 rule/are ruling’ [Berria, 2004-02-26]
- e. Tigger Woodsek [...] lehen postuari eus-te-n dio *Non-habitual*  
 Tigger Woods-ERG first position-dat resist-TZE-INE have.3sgERG.3sgDAT  
 ‘Tigger Woods resists in the first position’ [Berria, 2004-09-04]
- (74) a. Amets-ek bere ohean lo egi-te-n du *Habitual*  
 Amets-ERG his bed-ine sleep do-TZE-INE have.3sgERG  
 ‘Amets sleeps in his bed’
- b. Jon-ek Miren-i itxaro-te-n dio *Habitual*  
 John-ERG Mary-DAT wait-TZE-INE have.3sgERG.3sgDAT station-INE  
 ‘John waits for Mary in the station’

Regarding the K-states listed, all of them have a non-habitual interpretation: those which have an available synthetic form get a non-habitual reading in the synthetic configuration (75ab) and those which do not have it obtain a non-habitual reading in

<sup>99</sup> Recall that I am dealing with out of the blue data. If these examples were placed within a narrative context, then, they could have a non-habitual, on-going reading (see chapter 8).

the *-tzen* analytic form (75c). Finally, the predicates which have a bare analytic form, also get a non-habitual interpretation in that configuration (75d).

- (75) a. Mikel-ek erantzuna daki *Non-habitual*  
 Michael-ERG answer.ABS knows  
 ‘Michael knows the answer’
- b. Gure ahulezia horretan datza *Non-habitual*  
 our weakness.ABS this-INE lies  
 ‘Our weakness lies in that’
- c. Amets-ek 12 kg pisa-tze-n du *Non-habitual*  
 Amets-ERG 12 kg weigh-TZE-INE have.3sgERG.3sgABS  
 ‘Amets weighs 12 kg’
- d. Jon-ek Mikel gorroto du *Non-habitual*  
 John-ERG Michael.ABS hatred have.3sgERG.3sgABS  
 ‘John hates Michael’

Now, let us analyze the behavior of these predicates in the tests used to discriminate between D-states and K-states. In section 6.2.2, I identified four contexts where D-states contrast with K-states: (i) as infinitives of perception predicates; (ii) combined with locative adverbials; (iii) combined with manner adverbials; and (iv) the interpretation of the modifier ‘a little’.

All the D-states listed are grammatical as infinitival complements of the perception predicate *ikusi* ‘to see’:

- (76) a. Erlojua distira-tze-n ikus-i dut  
 clock.ABS shine-TZE-INE see-TU have.1sgERG.3sgABS  
 ‘I have seen the clock shining’
- b. Miren Jon-i itxaro-te-n ikus-i dut  
 Mary.ABS John-DAT wait-TZE-INE see-TU have.1sgERG.3sgABS  
 ‘I have seen Mary waiting for John’
- c. PP Espainia goberna-tze-n ikus-i dugu urte luzez  
 PP.ABS Spain.ABS rule-TZE-INE see-TU have.1plERG.3sgABS year long-INSTR  
 ‘We have seen the PP ruling Spain for a long time’
- d. Amets lo egi-te-n ikus-i dut  
 Amets.ABS sleep do-TZE-INE see-TU have.1sgERG.3sgABS  
 ‘I have seen Mary waiting for John’

K-states, in contrast, are not:

- (77) a. \*Mikel erantzuna jakiten ikus-i dut  
 Michael.ABS answer.ABS know-TZE-INE see-TU have.1sgERG.3sgABS  
 ‘\*I have seen Michael knowing the answer’
- b. \*Jon Ane ezagu-tze-n ikus-i dut  
 John.ABS Ane.ABS know-TZE-INE see-TU have.1sgERG.3sgABS  
 ‘\*I have seen John knowing Ane’

- c. \*Amets 12 kg pisa-tze-n ikus-i dut  
 Amets.ABS 12 kg weigh-TZE-INE see-TU have.1sgERG.3sgABS  
 ‘\*I have seen Amets weighing 12 kg’
- d. \*Irati Peru gorroto izaten ikus-i dut  
 Irati.ABS Peru.ABS hatred be-TZE-INE see-TU have.1sgERG.3sgABS  
 ‘\*I have seen Irati hating Peru’

This clear contrast indicates that the predicates listed in (52) –D-states– constitute spatiotemporal entities and that they are perceptible. K-states, on the contrary, cannot be perceived and, thus, cannot be the complements of perception predicates.

Regarding the compatibility with locative adverbials, most of the predicates listed as D-states are compatible with such modifiers.

- (78) a. Izarrek zeruan distira-tze-n dute  
 stars-ERG sky-INE shine-TZE-INE have.3plERG  
 ‘The stars shine in the sky’
- b. Miren-ek proiektu bat zuzen-tze-n du unibertsitate-an  
 Mary-ERG project a.ABS direct-TZE-INE have.3sgERG university-INE  
 ‘Miren heads a project in the university’
- c. Ane-k Amets-i itxaro-te-n dio tren geltoki-an  
 Ane-ERG Amets-DAT wait-TZE-INE have.3sgERG.3SGDAT train station-INE  
 ‘Ane waits for Amets in the train station’
- d. Amets-ek bere gela-n egi-te-n du lo  
 Amets-ERG his room-INE do-TZE-INE have.3sgERG sleep  
 ‘Amets sleeps in his room’

K-states like ‘know’, ‘weigh’ and ‘resemble’, in contrast, are not:

- (79) a. \*Ane-k erantzuna daki unibertsitatean  
 Ane-ERG answer.ABS knows university-INE  
 ‘\*Ane knows the answer in the university’
- b. \*Amets-ek 12 kg pisatzen du bere gelan  
 Amets-ERG 12 kg weigh-TZE-INE have.3sgERG room-INE  
 ‘\*Amets weighs 12 kg in the room’
- c. \*Amets-ek bere aita-ren antza dauka etxean  
 Amets-ERG his father-GEN resemblance has home-INE  
 ‘\*Amets resembles his father at home’

The same pattern is found with manner adverbials. Manner adverbials are generally accepted in the verbs of (52):

- (80) a. Izarr-ek bizi-bizi distira-tze-n dute gaur  
 stars-ERG intensely shine-TZE-INE have.3plERG today  
 ‘Starts shine intensely today’
- b. Miren-ek oso era antolatu-an zuzentzen du proiektua  
 Mary-ERG very way ordered-INE direct-TZE-INE have.3sgERG project.ABS  
 ‘Mary directs the project in a very ordered way’

- c. Amets-ek lasai-lasai egi-te-n du lo bere gela-n  
 Amets-ERG very calm do-TZE-INE have.3sgERG sleep his room-INE  
 ‘Amets sleeps calmly in his room’
- d. Ane-k buruari bueltaka itxaron dio Peruri  
 Ane-ERG head-DAT turn-KA wait-TU have.3sgERG.3sgDAT Peru-DAT  
 ‘Ane has waited for Peru mulling something over in her head’

The K-states, in contrast, do not accept this kind of modifiers.

- (81) a. \*Ane-k oso era antolatu-an daki erantzuna  
 Ane-ERG very way ordered-INE knows answer.ABS  
 ‘\*Ane knows the answer in an ordered way’
- b. \*Amets-ek 12 kg pisa-tze-n du oso era bortitzean  
 Amets-ERG 12 kg weigh-TZE-INE have.3sgERG very way extreme-INE  
 ‘\*Amets weighs 12 kg in a very extreme way’
- c. \*Ametsek bere aita-ren antza dauka lasai-lasai  
 Amets-ERG his father-GEN resemblance has calmly  
 ‘\*Amets resembles his father calmly’

Another diagnostic that I want to highlight is the compatibility with the progressive. As it has been noticed (Dowty 1979, Parsons 1990 among others) –and I have mentioned at the beginning of this section– some stative predicates are compatible with progressives, a context which is usually restricted to non-states. D-states pattern with activities in accepting the progressive, while K-states do not.

- (82) a. Irati dantza-tze-n ari da  
 Irati.ABS dance-TZE-INE PROG be.3sgABS  
 ‘Irati is dancing’
- b. Miren ikerketa egitasmo bat zuzen-tze-n ari da  
 Mary.ABS research project a.ABS direct-TZE-INE PROG be.3sgABS  
 ‘Mary is directing a research project’
- c. PP Espainia goberna-tze-n ari da  
 PP.ABS Spain.ABS govern-TZE-INE PROG be.3sgABS  
 ‘The PP is governing Spain’
- d. Izarra distira-tze-n ari da  
 star.ABS shine-TZE-INE PROG be.3sgABS  
 ‘The star is shining’
- (83) a. \*Mikel erantzuna jakiten ari da  
 Michael.ABS answer.ABS know-TZE-INE PROG be.3sgABS  
 ‘\*Michael is knowing the answer’
- b. ?? Jon Mikel gorrota-tze-n ari da  
 John.ABS Michael.ABS hate-TZE-INE PROG be.3sgABS  
 ‘\*John is hating Michael’
- c. \*Amets aita-ren antza iza-te-n ari da  
 Amets.ABS father-GEN resemblance be-TZE-INE PROG be.3sgABS  
 ‘\*Amets is resembling his father’



- d. \*Gure ahuleziak horr-etan etza-te-n ari dira  
 our weakness.ABS that-INE lie-TZE-INE PROG be.3plABS  
 ‘\*Our weakness are lying in that’

Finally, the last test that I will use involves the interpretation of the modifier ‘a little’. As I mentioned previously, ‘a little’ can have two meanings: (i) a time span reading, where it entails that the eventuality holds for a short time; and (ii) a degree reading, where it entails that the property denoted by the predicate comes in a small amount. Maienborn (2005), Rothmayr (2009) and Fábregas & Marín (2012) note that when ‘a little’ occurs with homogenous eventualities (activities and D-states), the temporal meaning of that modifier is available. The availability of the degree reading, on the other hand, will depend on the specific meaning of the predicate. Nevertheless, if it is combined with K-stative predicates, it yields only the degree reading.

When we apply this test to Basque data, many interesting issues emerge. The interpretation of *apur bat* ‘a little’ is dependent to a great extent on the *-tu/-tzen* marking of the predicates. With homogenous eventive predicates, like *dantzatu* ‘dance’, *apur bat* gets a temporal reading, both in *-tu* and in *-tzen* analytic configurations. Note that in the latter, the interpretation is habitual, so that *apur bat* modifies the duration of a plural number of events.<sup>100</sup>

- (84) a. Irati-k apur bat dantza-tu du *Temporal reading*  
 Irati-ERG little a dance-TU have.3sgERG  
 ‘Irati has danced a little’  
 b. Irati-k apur bat dantza-tze-n du (goizero) *Temporal reading*  
 Irati-ERG little a dance-TZE-INE have.3sgERG (every morning)  
 ‘Irati dances a little (every morning)’

When the D-state predicates listed in (52) are headed by *-tu*, *apur bat* always obtains a temporal interpretation (85). In contrast, when the predicates are headed by *-tzen*, the reading depends on the predicate. In those predicates which have a non-habitual reading in the *-tzen* configuration, *apur bat* has a degree reading (86). In those

<sup>100</sup> As pointed out by Etxepare (p.c.), the sentence in (xxv) can have another interpretation, related to the capacity of the subject:

- (xxv) Irati-k apur bat dantza-tze-n du  
 Irati-ERG little a dance-TZE-INE have.3sgERG  
 ‘Irati knows a little bit of dancing’

This interpretation is not considered in the analysis. Nevertheless, I suspect that, in this case, the measure associated to the Rheme (the Root *dantza*) is not incremental as in the other contexts. It would be, then, more similar to *distira* ‘shine’. This variability in the type of measure associated to the Root *dantza* suggests that contextual factors also play a role in the determination of the property and the measure associated to the Rheme, as mentioned in chapter 2, sec. 2.2.1, and chapter 4, sec. 4.3.1.

which have a habitual interpretation, it has a temporal reading (87), as it does with the activity verb *dantzatu* when headed by *-tzen* (84b).

- (85) a. Eguzkia-k apur bat distiratu du *Temporal reading*  
 sun-ERG little a shine-TU have.3sgERG  
 ‘The sun has shined a little’  
 b. PPK Espainia goberna-tu du apur bat  
 PP-ERG Spain.ABS govern-TU have.3sgERG little a  
 ‘The PP has governed Spain a little’  
 c. Jon-ek apur bat manten-du du bere estatusa  
 John-ERG little a maintain-TU have.3sgERG.3sgABS his status.ABS  
 ‘John has maintained his status a little bit’  
 d. Amets-ek apur bat lo egi-n du  
 Amets-ERG little a sleep do-TU have.3sgERG  
 ‘Amets has slept a little’  
 e. Jonek Mikel-i apur bat itxaro-n dio  
 John-ERG Michael-DAT little a wait-TU have.3sgERG.3sgDAT  
 ‘John has waited for Michael a little’
- (86) a. Eguzkiak apur bat distira-tze-n du *Degree reading*  
 sun-ERG little a shine-TZE-INE have.3sgERG  
 ‘The sun shines a little’  
 b. Elizak Espainia goberna-tze-n du apur bat  
 church-ERG Spain.ABS govern-TZE-INE have.3sgERG little a  
 ‘The church governs Spain a little’  
 c. Jon-ek bere estatusa manten-tze-n du apur bat  
 John-ERG his status.ABS maintain-TZE-INE have.3sgERG.3sgABS little a  
 ‘John has maintained his status a little bit’
- (87) a. Amets-ek apur bat lo egi-te-n du *Temporal reading*  
 Amets-ERG little a sleep do-TZE-INE have.3sgERG  
 ‘Amets sleeps a little’  
 b. Jon-ek apur bat itxaro-te-n dio Mikeli  
 John-ERG little a wait-TZE-INE have.3sgERG.3sgDAT Michael-DAT  
 ‘John waits a little for Michael’

Let us analyze now the behavior of K-states with the modifier *apur bat*. Recall that Basque K-states consist of predicates in their synthetic form, predicates in the *-tzen* analytic form and bare analytic predicates. Within these configurations, *apur bat* gets invariably a degree reading.

- (88) a. Mikelek matematikaz daki apur bat *Degree reading*  
 Michael-ERG maths-INSTR knows little a  
 ‘Michael knows a little of maths’  
 b. Jon-ek Mikel ezagutzen du apur bat  
 John-ERG Michael.ABS know-TZE-INE have.3sgERG.3sgABS little a  
 ‘John knows Michael a little’  
 c. Amets-ek aita-ren antza dauka apur bat

- Amets-ERG father-GEN resemblance has little a  
 ‘Amets resembles his father a little’
- d. Miren-ek Irati gorroto du apur bat  
 Mary-ERG Irati.ABS hatred have.3sgERG.3sgABS little a  
 ‘Mary hates Irati a little’

A remarkable property of K-states is that, in order to keep their Kimian interpretation, they have to be aligned in the configurations appearing in (88). If they are taken out of those forms and put within a *-tu* analytic form, their meaning changes: they become inchoative (see chapter 8, sec. 8.4.3 for a discussion). Some of them do not sound very natural with *apur bat* or are not grammatical under *-tu* (e.g. *pisatu* ‘to weigh’), but in those predicates which accept them, *apur bat* has a degree interpretation.

- (89) a. Ane-k Mikel apur bat ezagutu du *Degree reading*  
 Ane-ERG Michael.ABS little a know-TU have.3sgERG.3sgABS  
 ‘Ane has met Michael a little’
- b. Iratik apur bat gorrotatu du Peru  
 Irati-ERG little a hatred-TU have.3sgERG.3sgABS Peru.ABS  
 ‘Irati has hated Peru a little’
- c. ?Ane-k erantzuna apur bat jakin du  
 Ane-ERG answer.ABS little a know-TU have.3sgERG.3sgABS  
 ‘Ane has known the answer a little’
- d. \*Amets-ek apur bat pisatu du  
 Amets-ERG little a weigh-TU have.3sgERG  
 ‘\*Amets has weighed a little’

I believe that the degree interpretation in (89) results from the fact that these predicates are no longer homogenous when placed under *-tu*. They become eventive and at the same time heterogeneous, i.e. they involve a transition to a final state (a result), and *apur bat* ‘a little’ seems to modify that state. This property of *apur bat* is also observed in result predicates like *apurtu* ‘to break’, *lehortu* ‘to dry’ and *ureztatu* ‘to water’, analyzed in chapter 1, where *apur bat* has scope over the result subevent.

- (90) a. Amets-ek aldizkaria apur-tu du apur bat *Degree reading*  
 Amets-ERG magazine.ABS bit-TU have.3sgERG.3sgABS little a  
 ‘Amets has broken the magazine a little’
- b. Arropa apur bat lehortu da  
 clothes.ABS little a dry-TU be.3sgABS  
 ‘The clothes have dried a little’
- b. Aingeru-k landareak ureztatu ditu apur bat  
 Aingeru-ERG plants.ABS water-INSTR-TA-TU have.3sgERG.3plABS little a  
 ‘Aingeru has watered the plants a little’

According to this test, the D-states listed in (52) would be at the border of activity predicates like ‘dance’ and canonical stative predicates like ‘know’: when headed by *-tu*, *apur bat* gets a temporal reading, like in ‘dance’ and unlike in ‘know’; but when headed by *-tzen*, *apur bat* has a degree reading, unlike in ‘dance’ and like in ‘know’.

The summary of the results is presented in the next section.

### 6.3.3. Summary of results

The overall results are summarized in the following table:

**Table 6.2.** Comparison of the aspectual behavior between Basque Process verbs, D-states and K-states.

|                                                                  | Process verbs<br>(e.g. <i>dantzatu</i><br>‘dance’) | D-states<br>(e.g. <i>distiratu</i><br>‘govern’) | K-states<br>(e.g. <i>jakin</i><br>‘know’) |
|------------------------------------------------------------------|----------------------------------------------------|-------------------------------------------------|-------------------------------------------|
| subinterval property                                             | –                                                  | +                                               | +                                         |
| complement of <i>bukatu/amaitu</i><br>‘finish’                   | +                                                  | –                                               | –                                         |
| compatibility with slowly or<br>gradually                        | +                                                  | –                                               | –                                         |
| habitual reading in present tense                                | +                                                  | +/–                                             | –                                         |
| infinitival complement of<br>perception verbs                    | +                                                  | +                                               | –                                         |
| event-related manner adverbial                                   | +                                                  | +                                               | –                                         |
| event-related place adverbial                                    | +                                                  | +                                               | –                                         |
| time-spam reading with ‘a little’<br>when headed by <i>-tu</i>   | +                                                  | +                                               | –                                         |
| compatibility with the progressive                               | +                                                  | +                                               | –                                         |
| time-spam reading with ‘a little’<br>when headed by <i>-tzen</i> | +                                                  | +/–                                             | –                                         |

Most predicates listed in (52) behave as D-states in other languages like German and Spanish.<sup>101</sup> D-states in Basque pattern with activities in some contexts but differ

<sup>101</sup> The case of the predicates *itxaron* ‘to wait’ and *lo egin* ‘to sleep’ is a difficult one. They pattern mostly with activities. They only differ from them in not accepting to be combined with ‘slowly’ or ‘gradually’ and in not being a suitable complement of *bukatu/amaitu*. Crucially, they depart from the rest of D-states in not having a non-habitual reading in the Basque “present tense” and in that *apur bat* ‘a little’ has not a

from them and behave like statives in others. I argue, following Maienborn (2005 2007), that these predicates do contain an event argument and that this is what makes them act sometimes like activities. The first four tests illustrated in the table above involve the type of measure associated to the Rheme ([±incremental], [±lower bound] and [±upper bound]), and precisely in these four tests, D-states pattern with K-states. The rest of the tests listed, in contrast, are associated to the projection of the event argument, introduced by the *proc* subevent, as proposed by Fábregas & Marín (2012). *Proc* introduces the event argument and, thus, it provides the predicate with a spatiotemporal variable.

The D-states listed, therefore, project a process head, while the K-states do not. As suggested by Fábregas & Marín too, I consider that dynamicity must be divorced from the process head, because process provides eventivity but the dynamicity comes from the complement of the process head.

#### 6.3.4. Decomposition of D-states

Fábregas & Marín argue that the stative like behavior of D-states comes from the nature of the complement of the process head. According to them, in D-states Process selects for an adposition of central coincidence and this makes the predicate be non-dynamic and behave like a stative predicate in certain tests. They propose that a sentence like (91a) has the syntactic structure of (91b).

- (91) a. Juan gobierna España  
       John rules Spain

---

degree reading in that configuration. It is intriguing why these predicates do not behave like other non-dynamic eventive predicates in those contexts.

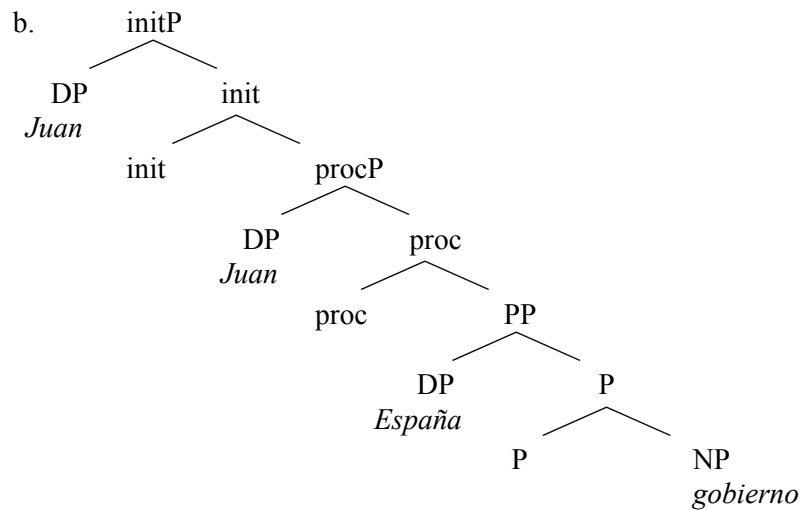

According to Fábregas & Marín (2012), the sentence in (91a) can be paraphrased as ‘Juan has Spain under govern’, the internal argument being the Figure of the adposition of central coincidence.

The analysis that I propose is very similar but it departs from it in certain aspects. I believe, following Fábregas & Marín, that two factors that are playing a role in the particular interpretation of these predicates are: (i) the lack of dynamicity; and (ii) the presence of an adposition of central coincidence. Nevertheless, I do not think that these two factors are interrelated. They propose that the selection of an adposition of central coincidence by *proc* makes the predicate non-dynamic. In contrast, I claim that these two properties do not always imply one-another. As I already mentioned in chapter 4, I suggest that the lack of dynamicity comes from the structure of the measure associated to the Rheme: if the measure is [+incremental] or [+transitional], the Rheme will be dynamic (a PATH), while if it is not, it will be a non-dynamic Rheme. On the other hand, I propose that the central coincidence adposition in D-states is located higher than the process head, and that it selects for the nP.<sup>102</sup> The adposition does not trigger, *per se*, non-dynamicity. Instead, non-dynamicity is determined by the Rheme. The central coincidence adposition, which in chapter 7 will be claimed to be an instance of viewpoint aspect, orders the Assertion-time *within* the Event time (see Demirdache & Uribe-Etxebarria 2000 2004 2005). Since the event is non-dynamic, the interpretation is almost the same as that of stative predicates, with the difference that in D-states, a *proc* head is projected.

<sup>102</sup> Recall that the nP node is only used notationally. See chapter 5, section 5.3.

I suggest that this adposition is actually lexicalized by the inessive *-n* of the *-tzen* suffix in Basque. For instance, several works (Mateu & Amadas 1999, Demirdache & Uribe-Etxebarria 2000, Laka 2004 2006a) have suggested that this suffix, which is also used in the progressive construction, can be decomposed into the inessive adposition (*-n*) and a nominalizer morpheme (*-t(z)e*). I suggest that (92b) is the structure of the sentence (92a), leaving apart the external argument and the head introducing it.

- (92) a. Izarr-ek distira-tze-n dute  
 stars-ERG shine-TZE-INE have.3plERG  
 ‘The stars shine’

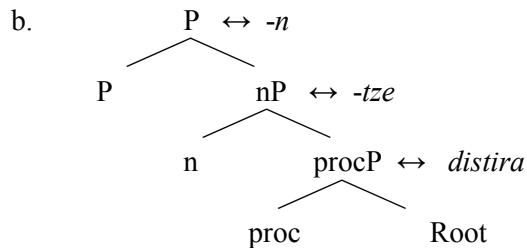

I propose that the adposition of central coincidence actually selects the whole nP and that it makes the predicate behave like a stative predicate in some syntactic tests. This D-state-like behavior, of course, is only possible if the predicate is non-dynamic: if *proc* does not select for a PATH or for a state subevent. Eventivity, on the other hand, emerges due to the presence of *proc* in the structure.

Regarding transitive D-states, I consider that the direct object is generated in the complement position of the Root (as suggested for non-homomorphic direct objects, see chapter 4, sec. 4.2.3. Then, I suggest that it moves to the specifier position of the central coincidence adposition (passing through [spec, nP] presumably), as all internal arguments.

- (93) a. Miren-ek ikerketa egitasmo bat kudea-tze-n du  
 Mary-ERG research project a.ABS manage-TZE-INE have.3sgERG.3sgABS  
 ‘Mary manages a research project’

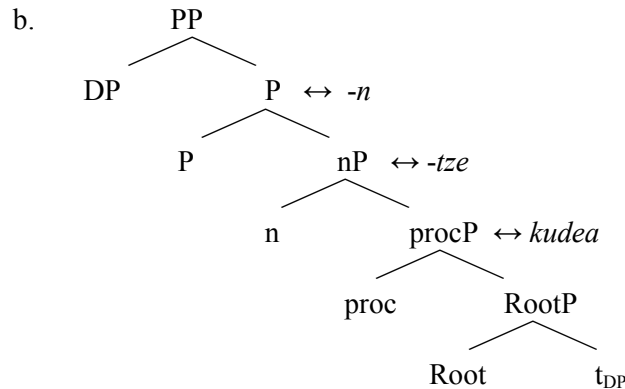

Thus, the absence of *-tu* and the presence of a non-dynamic Rheme are crucial in making these predicates behave like statives. On the one hand, in the *-tzen* analytic configuration, the predicate can have a natural non-habitual reading (like states do) and the modifier *apur bat* ‘a little’ has a degree reading (like in states).

- (94) a. *Izarr-ek distira-tze-n dute* *Non-habitual*  
 stars-ERG shine-TZE-INE have.3plERG  
 ‘The stars shine’
- b. *PPk Espainia goberna-tze-n du* *Non-habitual*  
 PP-ERG Spain.ABS govern-TZE-INE have.3sgERG  
 ‘The PP governs Spain’
- (95) a. *Eguzkia-k apur bat distira-tze-n du* *Degree reading*  
 sun-ERG little a shine-TZE-INE have.3sgERG  
 ‘The sun shines a little’
- b. *Eliza-k Espainia goberna-tze-n du apur bat*  
 church-ERG Spain.ABS govern-TZE-INE have.3sgERG little a  
 ‘The church governs Spain a little’

On the other, the lack of dynamicity also causes that transitive D-states cannot be the complement of *bukatu/amaitu* ‘finish’, and that both transitive and intransitive D-states cannot be modified by *poliki-poliki* ‘slowly’:

- (96) a. *\*Eguzkia-k distira-tze-n buka-tu du*  
 sun-ERG shine-TZE-INE finish-TU have.3plERG  
 ‘\*The sun has finished shining’
- b. *\*PPk Espainia goberna-tze-n buka-tu du*  
 PP-ERG Spain.ABS govern-TZE-INE finish-TU have.3sgERG  
 ‘\*PP has finished ruling Spain’
- (97) a. *\*Eguzkia-k poliki-poliki distira-tze-n du*  
 sun-ERG slowly shine-TZE-INE have.3sgERG  
 ‘The sun shines slowly’





- (100) a. Irati lurr-ean belaunika-tu da *Assume reading*  
 Irati.ABS floor-INE kneeling-TU be.3sgABS  
 ‘Irati has kneeled down on the floor’  
 b. Irati oholtza gainean zuti-tu zen  
 Irati.ABS platform top-INE standing-TU be.3sgABS.PST  
 ‘Irati has stood up in the platform’  
 c. Zezena bat-batean gelditu zen  
 bull.ABS suddenly still-TU be.3sgABS.PST  
 ‘The bull suddenly stopped’

Thus, as can be seen in the data, when *proc* selects for a central coincidence relation (e.g. *belauniko* ‘kneeling’, *geldi* ‘still’), the predicates do not become stative-like and do not have a D-state distribution. When a central coincidence relation is selected by *proc*, their relation is interpreted as implication, and the central coincidence relation becomes a *res*, triggering a dynamic interpretation of the entire predicate. Recall, in this sense, that the adposition may even be overt in certain predicates, for example in *result -ka* deadverbial predicates (e.g. *sail-ka-tu* ‘to classify’), or in deadpositional location verbs. Remarkably, as I mentioned in chapter 5, there are a few instances in the language where location predicates are built on inessive phrases (see ch.5, sec. 5.2.2): e.g. *gain-ean-du* ‘to put sth on top of X’, *oste-n-du* ‘to hide’. These examples transparently show that when *-tu* attaches to a central coincidence PP, the resulting predicate is a change of state.

This would be the syntactic structure of the predicates of (100) headed by *-tzen*, without taking into account external argument and the head introducing it:

- (101) a. Irati lurr-ean belaunika-tze-n da  
 Irati.ABS floor-INE kneeling-TZE-INE be.3sgABS  
 ‘Irati kneels down on the floor’  
 b.
- 
- ```

graph TD
  PP["PP ↔ -n"] --- DP
  PP --- P1["P"]
  P1 --- P2["P"]
  P1 --- nP["nP ↔ -tze"]
  nP --- n
  nP --- procP["procP"]
  procP --- proc
  procP --- resP["resP ↔ belaunika"]
  resP --- tDP["tDP"]
  resP --- res1["res"]
  res1 --- res2["res"]
  res1 --- Root
  
```

The internal argument *Irati* has originated in the specifier position of the state subevent lexicalized by *belauniko* ‘kneeling’. After merging *proc*, the state becomes a *res*. The fact that the internal argument is the specifier of the *res* subevent is a determinant difference between transitive D-states and dynamic predicates like *belaunikatu* ‘to kneel down’. In transitive D-states, the internal argument has not undergone a change of state/position.

Under the influence of the central coincidence Asp head, the predicate in (101) has a habitual interpretation, or if the sentence was uttered in a narrative context, it could also get an on-going meaning. In any case, this would not be similar to the stative interpretation obtained in a sentence such as (93), repeated here (102), because in (101a) there is a result subevent, and the predicate is dynamic.

- (102) Miren-ek ikerketa egitasmo bat kudea-tze-n du  
 Mary-ERG research project a.ABS manage-TZE-INE have.3sgERG.3sgABS  
 ‘Mary manages a research project’

The sentence above with the predicate *kudeatu* ‘to manage, to administer’ can be paraphrased as ‘Miren has a research project under her administration/management’, following Fábregas & Marín’s (2012) analysis of Spanish D-states. In contrast to the sentence in (101a), the argument *ikerketa egitasmo bat* ‘a research project’ does not raise to the specifier of the central coincidence head from the specifier of an inner *resP*.

Put in other words, there is one factor that prevents an eventive predicate headed by *-tzen* from being a D-state: dynamicity. The dynamicity is obtained by means of two mechanisms (Fábregas & Marín to appear): the selection by *proc* of (i) a PATH object; or of (ii) a stateP (*resP*). If one of these aspects is met, the predicate will not get a D-state distribution, regardless of whether it is headed by *-tzen*.

### 6.3.5. Decomposition of K-states

In K-states, in contrast, *proc* is not projected but only a state subevent. The LIs lexicalizing the Root (*ezagu* ‘know’ in *ezagutu* ‘to know’, *balio* ‘value’ in *balio izan* ‘to cost, to be worth’ etc.) are specified to spell out a stateP node.<sup>104</sup> In the case of K-

<sup>104</sup> For instance, when some of these LIs occur with *-tu*, they represent change of state predicates, a fact which shows that these LIs can lexicalize by themselves whole statePs. See chapter 8, sec. 8.4.3, for an analysis of these stative/eventive alternations.

states appearing in the analytic *-tzen* configuration, the inessive *-n* lexicalizes the stateP.

- (103) a. Mikel-ek Jon ezagu-tze-n du  
 Michael-ERG John.ABS know-TZE-INE have.3sgERG.3sgABS  
 ‘Michael knows John’

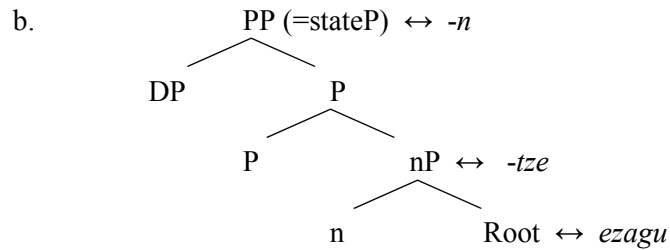

The LI *ezagu* can also lexicalize a stateP, but I assume that in this context, this feature is underassociated, and spelled out by the inessive *-n*. Since *proc* is not involved, K-states behave as canonical stative predicates in all syntactic contexts analyzed so far.

#### 6.4. A NOTE ON UNERGATIVE K-STATES

Some of the intransitive K-states analyzed in section 6.3 have ergative marked arguments and take auxiliary *\*edun* ‘have’.<sup>105</sup>

- (104) a. Ametsek 12 kg pisa-tze-n du  
 Amets-ERG 12 kg weigh-TZE-INE have.3sgERG  
 ‘Amet weighs 12 kg’  
 b. Ogiak 5 € balio du  
 bread-ERG 5 euro value have.3sgERG  
 ‘The bread costs 5 €’

I assume that HAVE/BE auxiliary selection alternation is a diagnostic of the unergativity/unaccusativity of the predicates, in line with Levin & Rappaport Hovav (1995). Thus, I consider that these predicates are unergative, and that their subject has been introduced by Voice.

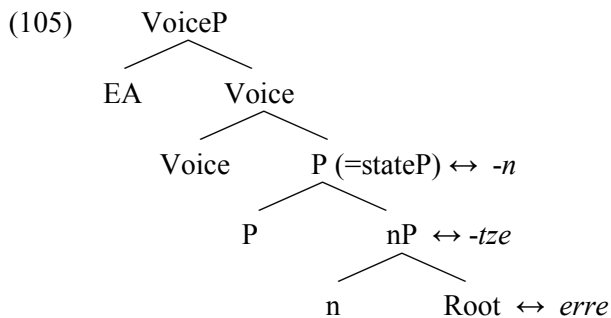

In this section, I will discuss on the reasons and implications of having the subject of these K-states introduced externally.

To begin with, it is remarkable that a central coincidence head, lexicalized by the inessive *-n* in stative predicates does not have a subject in its specifier. As argued in chapter 2, states must have a subject in their specifier position because states denote central coincidence relations and, in order for the predicate to be fully interpreted, it needs a subject to be predicated over (see Hale & Keyser 1993). Nevertheless, in unergative K-states like the ones analyzed in this section, the only subject is introduced by another central coincidence head, which I have labeled Voice.

<sup>105</sup> There are several unergative K-states in Basque like *usaindu* ‘to smell’, *irristatu* ‘to be slippery’, *pikatu* ‘be spicy’ etc. that are usually perceived to have emerged due to language contact. See Berro (in press) for an analysis of this kind of predicates.

In my analysis, the head introducing the external argument is a stative head, similar to the adposition ‘with’ (see chapter 7). I claim that in this case, where two state subevents (one labeled Voice and the other being the PP) have a single subject, both subevents are identified, giving rise to a scenario similar to the one depicted by Kratzer (1996). Kratzer (1996) argues that the Merge of Voice and VP is interpreted as *Event Identification*, where both properties of events introduced by Voice and VP are identified as a single one. I claim that, in the case of the unergative K-states described above, Event Identification is taking place.

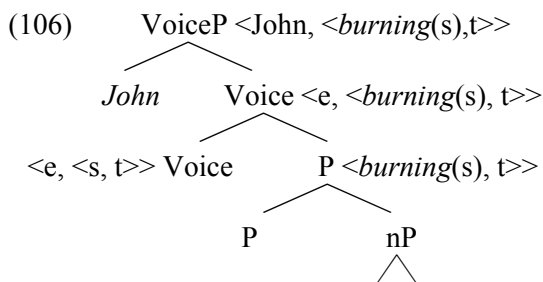

In this diagram, *e* is the type of individuals, *s* the type of events and *t* the type of truth-values. Merging Voice and P, the type of event introduced by P and that introduced by Voice are identified as a single one. Note that this can only happen if two state subevents are merged, and if the lower state does not introduce a subject. For instance, if Voice is merged with *proc*, their relation will be interpreted as implication (as claimed in chapter 2, sec. 2.2.1). On the other hand, if Voice merges with a P which introduces a subject in its specifier, their relation is also going to be interpreted as implication. Event identification only takes place between two subevents of the same type (two states) and when the lower one does not contain a subject.

Consider, in this sense, a transitive K-state predicate like the following:

- (107) a. Jon-ek Mikel ezagu-tze-n du  
 John-ERG Michael.ABS know-TZE-INE have.3sgERG.3sgABS  
 ‘John knows Michael’

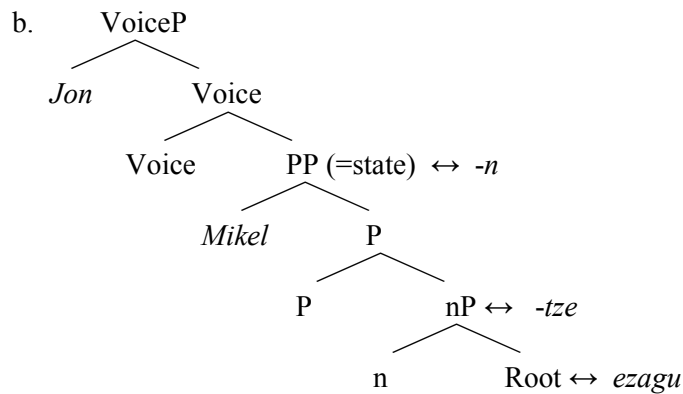

I claim that this sentence can be paraphrased as ‘John is with Michael in knowledge’ or ‘John has Michael in knowledge’. As can be seen, in transitive K-states the two central coincidence heads, Voice and PP (‘with’ and ‘in’) are kept separate. The relation between both states is interpreted as implication. However, when the P lacks a subject in its specifier, as in the predicates analyzed in this section, both subevents are related by Event Identification.

In chapter 7, I will continue the discussion on D- and K-states and the introduction of the subject in intransitive predicates.

## 6.5. CONCLUSION

In this chapter, I have proposed, following Maienborn (2005 2007), Rothmayr (2009) and Fábregas & Marín (2012), that there are actually two types of stative predicates: Davidsonian states –non-dynamic but eventive predicates– and Kimian states –non-dynamic and non-eventive predicates. I have revised and applied to Basque the tests which are used to differentiate these two types of predicates, and showed, that in Basque, there are actually several predicates belonging to both classes.

Regarding their syntactic and eventive decomposition, I have followed Hale & Keyser (2002) in suggesting that a central coincidence relation is involved in the interpretation of a given predicate as a state. I have claimed that a central coincidence head is present in both D- and K-states, but that, in D-states, a *proc* head is also projected. More specifically, I have argued that a D-state-like distribution arises when *proc* selects for a non-dynamic Rheme, which, as claimed in chapter 4, involves that the Rheme is associated to an [–incremental] and [–transitional] measure. When an event of this type is selected by a central coincidence Asp head, the interpretation is very similar to that of canonical states, since the event does not involve any progression.

Finally, I have considered the fact that some K-states, which consist of a state subevent, are actually unergative, and have their subject introduced by Voice. Building on Kratzer (1996), I have argued that when two stative subevents are merged, if the one in complement position lacks a specifier, both states are identified by means of Event Identification.

In the following chapter, I will continue considering the relation between eventivity/stativity and the introduction of the subject. As I will show, contrary to what happens in K-states, in eventive predicates the introduction of the subject in [spec, VoiceP] or in [spec, stateP] triggers an important semantic difference.





**7. The introduction of the external argument and the interaction between situation and viewpoint aspect**



## 7.1. INTRODUCTION

This chapter is a natural continuation of the claims made in chapter 6. In chapter 6, I explored predicates which are at the boundary between eventivity and stativity and I made an analysis of D-states and K-states. In this chapter, I will continue studying the limit between eventivity and stativity, but, this time, in relation with the head introducing the external argument and the interaction between viewpoint and situation aspect.<sup>106</sup>

Basing on the characterization of D-states and K-states made in chapter 6, in this chapter I will test a prediction regarding the introduction of subjects in D-states:

- (1) Prediction on D-states and K-states
  - a. D-states must not have an internal subject
  - b. K-states can have either an external or an internal subject

This prediction is motivated by three aspects of the analysis made in this dissertation: (i) that subjects (both internal and external) are introduced by state subevents; (ii) that, in D-states, a *proc* head is projected, whereas in K-states it is not; and (iii) that D-states must be non-dynamic. As I will show, the conjunction of these three aspects justifies the prediction illustrated in (1), since the combination of the higher state (Voice) and *proc* does not trigger dynamicity, but, in contrast, the combination of *proc* and state (*res*) does.

According to this prediction, D-states must be either unergative predicates or transitive predicates involving no internal subjects. K-states, in contrast, can be either unergative, unaccusative or transitive predicates. As we will see, this prediction is actually born out both in Basque and cross-linguistically.

Before getting to (1), I will make an analysis of the head introducing the external argument (labeled Voice), and more specifically, of its relation with the process subevent. Building on the conception of the initiation subevent made in First Phase Syntax (Ramchand 2008a), I will propose –departing from Kratzer (1996)– that Voice is a stative head. Crucially, its interpretation varies on the basis of the whole first phase configuration. Depending on its syntactic context, it can be interpreted as a state or as an initiating subevent. More specifically, when it is combined with *proc*, it will

---

<sup>106</sup> An analysis directly related to viewpoint aspect will be made in chapter 8.

be interpreted as initiation, and the subject in its specifier as an INITIATOR. As I will show, this characterization of Voice correctly predicts the unergative/unaccusative variation pattern observed in intransitive D- and K-states, and it is also supported by several Basque data.

The outline of the chapter is the following. Firstly, I will address the prediction (and generalization) on D- and K-states (sec. 7.2). Then, I will analyze the nature of the head introducing the external argument: first, I will comment on its varying interpretation (sec. 7.3.1); second, I will introduce the characterization of the initiation subevent in First Phase Syntax (sec. 7.3.2); third, I will suggest that Voice actually shares several properties with the adposition ‘with’ (sec. 7.3.3); and fourth, I will explain the factors which additionally influence the interpretation of the external argument (sec. 7.3.4). In the fourth section, K-states will be revisited. Following the analysis of Voice made in section 7.3, I will show that K-states are prone to vary with respect to the introduction of their subject –external or internal–, contrary to D-states which generally have an external subject. This contrast is attributed to the absence or presence of the *proc* head. In the fifth section, I offer two pieces of evidence supporting my proposal on Voice. I show that in some stative/eventive varying contexts, the ergative marked subject in Basque changes its interpretation, as it is expected from the relation between Voice and *proc*.

## 7.2. PREDICTION ON D- AND K-STATES

In chapter 6, I argued that there are two types of stative predicates (Maienborn 2005 2007, Rothmayr 2009, Fábregas & Marín 2012): D-states and K-states. Following Fábregas & Marín (2012), I claimed that D-states involve the projection of the process subevent, whereas K-states do not. Additionally, I proposed that, in D-states, the process subevent selects for a non-dynamic Rheme (a Rheme associated to a [–incremental] and [–transitional] measure). The selection of a non-dynamic Rheme makes the predicate non-dynamic, a necessary condition for D-states. As claimed in Fábregas & Marín (2012), I argued that dynamicity emerges as a consequence of (i) *proc* selecting a PATH object (a dynamic Rheme), or (ii) *proc* selecting for a state subevent (= *res*). This analysis, together with the claim made in this dissertation on the introduction of subjects, namely, that they are introduced by state subevents, make the following prediction about the insertion of subjects in D- and K-states.

- (2) Prediction on D-states and K-states
- a. D-states must not have an internal subject
  - b. K-states can have either an external or an internal subject

Let us explain this prediction step by step. My analysis of D-states involves the projection of *proc*. On the other hand, recall that, according to the proposal made in section 2.3.4, unaccusative predicates have internal subjects, and internal subjects originate in the specifier position of a state subevent. If *proc* is projected in such a configuration, the state subevent automatically becomes a *res*, and this would result in a dynamic interpretation, a meaning of change of state.

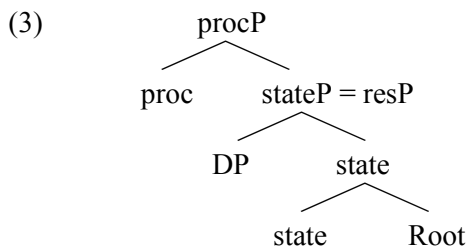

As commented before, dynamicity is incompatible with a D-state behavior. Therefore, my analysis of the introduction of subjects in unaccusative predicates and of the nature of D-states predicts that D-states cannot involve the projection of an internal subject. This means that D-states must not be unaccusative predicates or transitive predicates consisting of an internal subject (that is to say, an argument originated in [spec,stateP]).

On the other hand, in K-states, such a restriction does not exist. In K-states, *proc* is not projected, and thus, a subject can be introduced in either [spec, VoiceP] or in [spec, stateP], with that creating any alteration in the dynamicity of the predicate. Thus, intransitive K-states can be unaccusative or unergative. In section 7.4, I will return to the implications of my analysis in the alignment of K-states.

Regarding D-states, as commented before, the prediction made in (2) implies that D-states can be either unergative or transitive. In any case, if a D-state is transitive, its internal argument must not be an internal subject, that is to say, it must not be in the specifier position of a state subevent. If we look at the examples of D-states cited in the literature, it seems that the prediction is actually born out. Most cited D-states are usually unergative: e.g. *sit, stand, lie, gleam, glow, bubble, sleep, wait, shine* etc. Recall, in this sense, that Levin & Rappaport Hovav (1995) and Rappaport Hovav & Levin (2000) argue that predicates of *maintaining a position* are unergative, whereas predicates of *simple position* are unaccusative (sec. 6.2.2). Rothmayr (2009) actually considers that the unergative class, that is, the class of predicates of maintaining a position, are D-states. On the other hand, she claims that the predicates of simple position are K-states. More specifically, Rothmayr (2009) proposes that predicates of maintaining a position project a DO operator –which provides the predicate with eventivity–, while predicates of simple position do not contain such an operator. Furthermore, in her analysis, this difference also explains the agentivity of predicates of maintaining a position, in contrast to those of simple position (see sec. 6.2.2.1). Thus, it seems that there is a clear connection between being a D-state and being unergative (or better said, not having an internal subject).

Fábregas & Marín (2012) examine a range of transitive D-states in Spanish; e.g. *gobernar* ‘to govern’, *presidir* ‘to head’, *dirigir* ‘to direct’ etc. They suggest that the internal argument of these predicates, like *España* in *Juan gobierna España* ‘Juan governs Spain’, originates in the specifier position of a central coincidence P.

Nevertheless, in the chapter 6 (sec. 6.3.4), I have argued against that analysis, claiming that the presence of a central coincidence PP below *proc* would yield a change of state interpretation. Moreover, within such an analysis, it is not clear how they would derive the formation of unergative D-states (which clearly lack an internal subject).

In chapter 6, I have argued that the direct object of transitive D-states originates in another position, i.e. in a position where it is not homomorphically related to *proc*: in the complement position of the Root (sec.4.3.3). Regarding the Basque predicates I have analyzed as D-states, we find both unergative and transitive verbs:

(4) Unergative D-states

a. Simple unergative verbs

*distiratu* ‘to gleam, to glow’, *itxaron* ‘to wait’, *eutsi* ‘to maintain’,  
*erreinatu* ‘to reign’

b. Complex unergative verbs

*lo egin* ‘to sleep’, *argi egin* ‘to gleam, to shine’, *dirdira egin* ‘to glow’,  
*kirrinka egin* ‘to creak’, *elurra egin* ‘to snow’, *euria egin* ‘to rain’

(5) Transitive D-states

*gobernatu* ‘to govern’, *zuzendu* ‘to direct’, *koordinatu* ‘to coordinate’,  
*mantendu* ‘to maintain’, *kontrolatu* ‘to control’, *errespetatu* ‘to respect’,  
*eskertu* ‘to thank’.

There are no unaccusative predicates attested among D-states, as predicted by my analysis. This fact is an additional evidence supporting both the characterization on D-states and the analysis of internal subjects.



### 7.3. THE PROPERTIES OF THE HEAD INTRODUCING THE EXTERNAL ARGUMENT

#### 7.3.1. Varying interpretation of the external argument

In the previous chapters, I have shown that the external argument, which is marked with ergative case, can have several different theta roles. Firstly, in chapter 3, I showed that it can be *causer*; an entity triggering (not necessarily voluntarily) a change of state or location of another entity.

- (6) a. Amets-ek aldizkaria apur-tu du  
 Amets-ERG magazine.ABS bit-TU have.3sgERG.3sgABS  
 ‘Amets has broken the magazine’  
 b. Hezetasuna-k egurra honda-tu du  
 humidity-ERG wood.ABS damage-TU have.3sgERG.3sgABS  
 ‘The humidity has damaged the wood’

Then, in chapter 4, I examined unergative and non-causative transitive predicates, where the external argument has an *actor* theta role.

- (7) a. Irati-k aureskua dantza-tu du  
 Irati-ERG auresku.ABS dance-TU have.3sgERG.3sgABS  
 ‘Irati has danced the auresku’  
 b. Aingeru-k oso ondo eskia-tze-n du  
 Aingeru-ERG very well ski-TZE-INE have.3sgERG  
 ‘Aingeru skis very well’  
 c. Maiderr-ek sagar bat ja-n du  
 Maider-ERG apple a.ABS eat-TU have.3sgERG.3sgABS  
 ‘Maider has eaten an apple’

And, finally, in chapter 6, I analyzed several predicates where the external argument is just a *holder* of a given property (in K-states) (8a,b) or is an *initiator* argument of a non-dynamic eventive predicate (in D-states) (8c):

- (8) a. Betaurrekoek [ondo ikusteko] balio dute  
 glasses-ERG [well see-TZE-GEN] value have.3plERG  
 ‘Glasses serve to see well’  
 b. Amets-ek 12 kg pisa-tze-n du  
 Amets-ERG 12 kg weigh-TZE-INE have.3sgERG  
 ‘Amets weighs 12 kg’

- c. Eguzkia-k distira-tze-n du  
 sun-ERG shine-TZE-INE have.3sgERG  
 ‘The sun shines’

In previous chapters, I have suggested that the head Voice introduces the external argument. But, how can the Voice head, as proposed in Kratzer (1994 1996) fit in this picture of varying theta roles? Kratzer (1994: 123) considers that stative subjects, such as *Mittie* in (9), are not causers, but holders. Kratzer notes that we need a head to add the external argument of these clauses that is different from the head introducing external arguments in action predicates, because the selection of VP by Voice takes place via Event Identification. According to her, “Event Identification is only defined if the two predicates that are being conjoined [VP and Voice] have compatible Aktionsarten” (Kratzer 1994: 122). If an eventuality is a state rather than an event, the head Voice cannot be identified with such an eventuality.

(9) Mittie owns the dog

In this respect, Alexiadou (2001:189) argues that subjects of stative predicates are better understood as possessors and experiencers, and not as true causers. The head introducing the external argument in Basque, which is related to ergative morphology, covers both contexts –active and stative scenarios. We are left with two options: (i) there are two types of Voice heads, one stative and one eventive; or (ii) there is a single head, but this head can have different interpretations depending on its complement. I will take the second option to be the simplest one and the correct one. I have called this head “Voice”, although the reader must be aware that this Voice is different from the Voice head originally proposed by Kratzer in that it does not always relate to its complement by means of Event Identification.<sup>107</sup> I retain the label in order to underscore its function as the case-licensor of the internal argument and that it is separated from the expression of the event configuration of the predicate. I will propose that this head can introduce *causers*, *actors* or *holders*, depending on the nature of its complement. This way, this proposal is built on the characterization of the initiation subevent made in First Phase Syntax (Ramchand 2008a).

<sup>107</sup> Recall that, in section 6.4, I argued that Voice and its complement are related by means of Event identification only when its complement is a state subevent and when this state subevent does not have a subject in its specifier. When its complement is a process subevent or a state subevent with a subject, the relation between Voice and its complement is interpreted as implication.

### 7.3.2. Initiation in First Phase Syntax

Firstly, I will introduce the derivation of theta roles in First Phase Syntax (Ramchand 2008a), and then, I will explain the aspects of this system that can be applied to my analysis.

Ramchand claims that the Initiation head, the head introducing the external argument, is a stative head. Recall that she (2008a: 44) states that *proc* is the heart of the dynamic predicate, and that, in contrast, *init* and *res* are states. Their specific interpretation is derived from their position in the hierarchical structure with respect to *proc*.

(10) IF  $\exists e1, e2$  [State( $e1$ )  $\cap$  Process( $e2$ )  $\cap$   $e1 \rightarrow e2$ ], then by definition Initiation( $e1$ ).

(11) IF  $\exists e1, e2$  [State( $e1$ )  $\cap$  Process( $e2$ )  $\cap$   $e2 \rightarrow e1$ ], then by definition Result( $e1$ ).

Thus, initiation is considered a state which leads to the process. The argument in its specifier, the INITIATOR, is an individuated entity that possesses the property denoted by the initiating subevent. Process, in contrast, introduces an UNDERGOER; “individuated entities whose position/state or motion/change is homomorphically related to some Path”, and result introduces a RESULTEE, “individuated entities whose state is described with respect to the resultative property/Ground” (Ramchand 2008a: 52). As I explained in the chapter 2, Ramchand assumes that a single argument can occupy more than one specifier position. This way, a given initiator argument can be either a causer or an actor. Causers can be considered “pure” initiators, i.e. arguments which only sit in the specifier of *init*. Thus, the other argument occupies both the specifier position of *proc* and of *res*. Basing on the semantic formulations given for *init*, *proc* and *res* by Ramchand, the following semantic description can be made of causation and of the causer argument.

(12) If  $\exists e1, e2, e3$  [State( $e1$ )  $\cap$  Process( $e2$ )  $\cap$  State( $e3$ )  $\cap$   $e1 \rightarrow (e2 \rightarrow e3)$ ], then by definition, Causation( $e1$ )  $\cap$  Result( $e3$ ).

(13) [[*causer*]] =  $\lambda P \lambda x \lambda y \exists e1, e2, e3$  [P( $x$ )  $\cap$  subject( $x, e1$ )  $\cap$  subject( $y, e2$ )  $\cap$  subject( $y, e3$ )  $\cap$  State( $e1$ )  $\cap$  Process( $e2$ )  $\cap$  State( $e3$ )  $\cap$   $e1 \rightarrow e2 \rightarrow e3$ ]

On the other hand, an actor or a volitional agent is derived in Ramchand's system as a composite role: an argument which is at the same time an INITIATOR and an UNDERGOER. These are some examples of UNDERGOER/INITIATOR arguments (Ramchand 2008a: 53):

- (14) a. *Karena* ran to the tree  
 b. *The diamond* sparkled  
 c. *Ariel* ate the mango  
 d. *Kayleigh* danced

The following semantic description can be made:

- (15) If  $\exists e_1, e_2$  [State ( $e_1$ )  $\cap$  Process ( $e_2$ )  $\cap e_1 \rightarrow e_2$ ], then by definition, Initiation ( $e_1$ ).
- (16)  $[[actor]] = \lambda P \lambda x \exists e_1, e_2$  [P( $x$ )  $\cap$  subject ( $x, e_1$ )  $\cap$  subject ( $x, e_2$ )  $\cap$  State ( $e_1$ )  $\cap$  Process ( $e_2$ )  $\cap e_1 \rightarrow e_2$ ].

Regarding the HOLDER argument of stative predicates, a crucial characterization of the *init* head is that, if it does not select for *proc*, as in (17), *init* is interpreted simply as a state and its argument is interpreted as a HOLDER of that state.

- (17) *Katherine* fears nightmares (Ramchand 2008a: 55-56)
- (18) If  $\exists x, e$  [Subject( $x, e$ )  $\cap$  State( $e$ )], then by definition holder( $x$ ).

In (17), *Katherine* is a true initiator, but this time, there are no *proc* and *res* subevents. *Katherine* is just the holder of the state denoted by the predicate. As notated by Ramchand, notating the subevent head as initiation in such a case is not necessary, since it is an independent verbal head corresponding to an autonomous state (p. 56).

In my analysis, I will adopt the basic semantic derivation of the external argument and the head introducing it made in First Phase Syntax. Nevertheless, I depart from the proposal made in Ramchand (2008a) in several aspects, which have already been made explicit throughout the dissertation. Firstly, I assume that the head introducing the external argument is separated from the expression of the event configuration of the predicate. As claimed in section 3.3, Voice is projected independently and higher

than the heads lexicalized by *-tu* (nP<sup>108</sup> and, in some cases, procP). Secondly, contrary to Ramchand (2008a), I consider that *proc* does not introduce a subject in its specifier (see chapter 1, sec.3.3). Taking into account the last difference, I reformulate the definitions of *causer* and *actor*.

$$(19) \quad [[causer]] = \lambda P \lambda x \lambda y \exists e_1, e_2, e_3 [P(x) \cap \text{subject}(x, e_1) \cap \text{subject}(y, e_3) \cap \text{State}(e_1) \cap \text{Process}(e_2) \cap \text{State}(e_3) \ \& \ e_1 \rightarrow e_2 \rightarrow e_3]$$

$$(20) \quad [[actor]] = \lambda P \lambda x \exists e_1, e_2 [P(x) \cap \text{subject}(x, e_1) \cap \text{State}(e_1) \cap \text{Process}(e_2) \cap e_1 \rightarrow e_2].$$

The projection of *proc* combined with the fact that *res* is not projected, is sufficient to derive the *actor* role of the INITIATOR.

### 7.3.3. Voice as WITH

The semantics of the Voice head advocated for in this dissertation is similar to that of the initiation subevent of First Phase Syntax. Voice is originally a stative head, which, depending on the type of its complement, may be interpreted as a state or as an initiation/source subevent. Recall that *res* is also a state subevent, which, after selected by *proc*, is interpreted as a result subevent. Thus, both are state subevents, which in First Phase Syntax, only differ with respect to the relation with *proc*. I will call “lower state” to the state subevent projected below *proc*, or in the absence of *proc*, to the state subevent lexicalized by the predicate.

In this section, I will claim that Voice and the lower state differ in certain aspects. More precisely, I propose that Voice is parallel in the adpositional domain to the possessive WITH<sup>109</sup>, which introduces a possessor in its specifier. The lower state, in contrast, is closer to the locative *in*, *on* or *at* (LOC for simplicity). The contrast and differentiation of (central coincidence) relational heads like WITH and LOC have been made in several works. For instance, Hale & Keyser (1993) argue that the difference between *locatum* and *location* predicates is derived from these two types of relational

<sup>108</sup> Recall that the nP node is used notationally to indicate that the predicate headed by *-tu* surfaces with nominal category. See section 5.3.

<sup>109</sup> I use WITH in capital letters to indicate that I am referring to the abstract relational element where the possessor is the specifier and not to the English adposition *with*.

elements, and Harley (1995 2002) posits a similar opposition to account for the difference between double object and double complement configurations.

As explained in chapter 2 and chapter 5, H&K (1993) argue that, in both location and locatum predicates, the dynamic predicate is built on a PP whose head is of central coincidence. In location predicates like *shelve*, V takes as a complement a silent P of central coincidence, similar to ‘in’ or ‘on’.

(21) a. He shelved the books

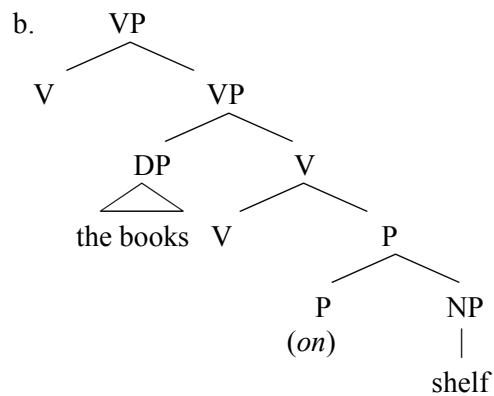

The central coincidence relation denoted by the preposition specifies that the Figure *the books* –positioned in the specifier of the inner VP– will end up located in the Ground *shelf* –positioned in the complement of the P.

In locatum predicates like *saddle*, in contrast, V selects for a P considered similar to the possessive ‘with’.

(22) a. He saddled the horse

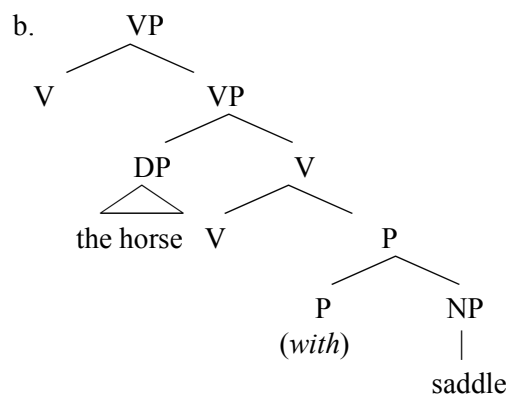

The sentence in (22) cannot be paraphrased as *he put a horse in/on the saddle*, but must otherwise be paraphrased as *he provided the horse with a saddle*. As can be seen, in this case the Figure *the horse* does not end up located in the landmark conveyed by the Ground *saddle*. Instead, the Figure ends up possessing the Ground. H&K argue that this difference is due to the nature of the silent preposition in locatum predicates, which would be akin to the possessive ‘with’. This preposition reverses the relation between the Figure and the Ground.

Thus, as can be seen, a central coincidence relation can be of two types: (i) a relation in which the entity in the specifier position is located in the landmark denoted by the complement (LOC), or; (ii) a relation where the complement is located in the specifier (WITH). The latter can be termed an *inclusion* relation, and the former a *containment* relation. The lower state denotes, then, an inclusion relation, whereas the Voice head denotes containment. Let me consider the stative predicates in (23), which H&K (2002) argue to involve the projection of a silent preposition:

- (23) a. Mary has my respect  
(cf. I respect Mary)  
b. She has the boss’s esteem  
(cf. The boss esteems her) (Hale & Keyser 2002: 209)

A sentence such as *the boss esteems Mary* can be further paraphrased as (24a) and has the structure in (24b):

- (24) a. The boss has Mary in esteem

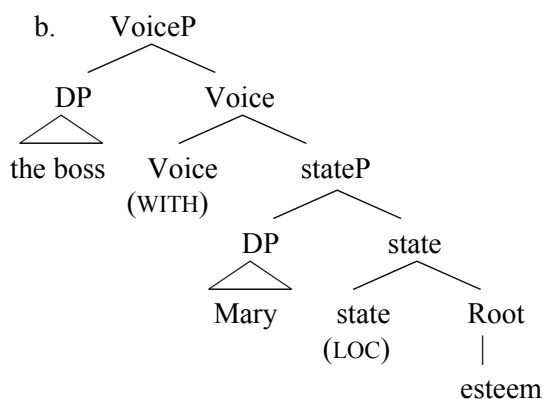

The external argument is projected in the specifier of Voice (WITH) and the internal subject in the specifier of stateP (LOC).

In relation to this, the relation between the adposition WITH and the verb *have* has been pointed out in some works (Hale & Keyser 2002, Levinson 2011). Harley (1995 2002) does not mention the adposition WITH, but she proposes that HAVE is the result of incorporating a prepositional HAVE into BE. The prepositional HAVE ( $P_{HAVE}$ ) is a *relational* head (not verbal) which takes in its specifier the possessor and in its complement the possessee. Thus, it is different from the locative relational head, where the possessor is in complement position and the possessee is in the specifier.

According to Harley (1995 2002), these two distinct relational heads are the bases for the double object and double complement configurations of the verb *give*.

- (25) a. I give Opus a book                      Double object (built on  $HAVE_P$ )  
       b. I give a book to Opus                 Double complement (built on LOC)

She considers that both the double object and the double complement configurations are base-generated, and suggests that they actually have different structures. The double object configuration of the predicate *give* can be decomposed into CAUSE X HAVE Y, whereas the double complement configuration is decomposed into CAUSE Y LOC X. Assuming the analysis of HAVE as derived from BE plus an adposition (Freeze 1992, Kayne 1993, Nash 1994, Mahajan 1994), Harley suggests that the possessive *have* is also decomposed into an Event head BE and  $P_{HAVE}$ , the same adposition found in the double object configuration (Harley 1995: 111-112).

- (26) a. Ronald-Ann has a book

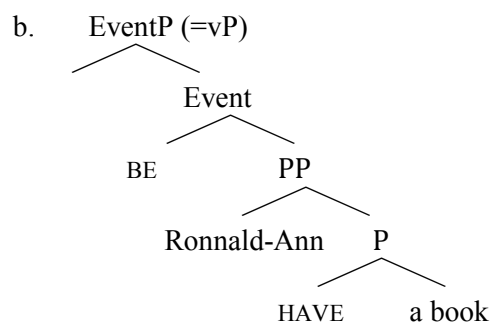



(27) a. Opus gave Ronald-Ann a book

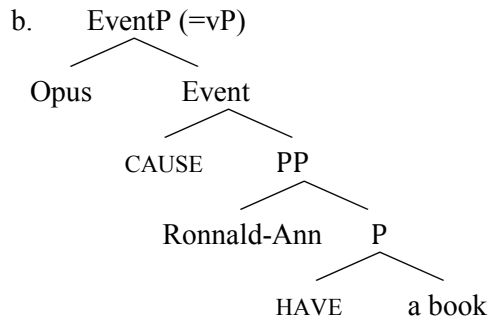

The double complement configuration, in contrast, is built on the relational element LOC. LOC can also be selected by BE, in which case, it gives rise to the locative:

(28) a. A book is on the shelf

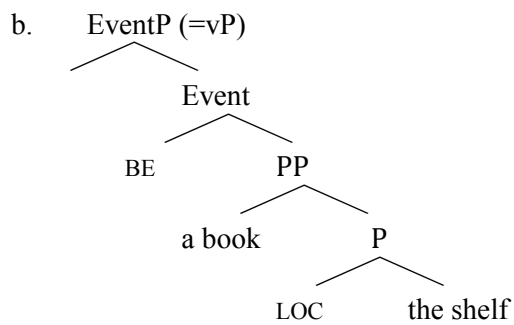

(29) a. Opus gave a book to Ronald-Ann

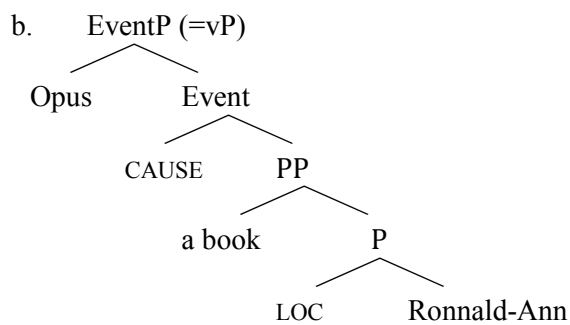

This characterization of the double object configuration makes interesting predictions concerning language variation. For instance, Harley (1995 2002) shows

that the languages which lack possessive HAVE also lack the double object construction (e.g. Scots Gaelic, Irish, Diné –Navajo–, Tagalog).<sup>110</sup>

I claim that the state subevents represented by Voice and the lower state can be differentiated in these terms. Both are central coincidence heads, but denote different spatial relations between their specifier and complement. On the other hand, they also differ in that Voice, although it is basically a state, has a context-dependent meaning

---

<sup>110</sup> At this point, the characterization of *with* made in Svenonius (2007) seems very enlightening. Svenonius (2007: 17-18) suggests that *with* is not a spatial P. According to him, spatial Ps never introduce a Figure complement, but a Ground. In some uses of *with*, like the ones described so far, it seems that *with* introduces in its complement position an argument with the role of Figure. Svenonius (2007), however, suggests that spatial Ps only introduce Ground complements. In this sense, he observes that the semantic contribution of *with* is extremely vague, contrary to the contribution of other spatial Ps like *on*. For instance, *with* can introduce different kinds of adjuncts such as instruments, manners, accompaniment, and accoutrements:

(xxvi) We sprayed the dog with a fire extinguisher

(xxvii) We sprayed the dog with glee

(xxviii) We sprayed the dog with an audience of boy scouts

(xxix) We sprayed the dog with raincoats to protect us from spatter

*On*, on the other hand, introduces only Grounds:

(xxx) We sprayed tomato juice on the lawn

(xxxi) We sprayed tomato juice on the Labor Day

(xxxii) We sprayed tomato juice on the grounds that it would make the dog smell good

The possibility to interpret the complement of *with* as the Figure of the relation seems to depend in a great extent on the predicate (viii-xi). Its interpretation seems to be derived from the whole construction.

(xxxiii) We left the dog with tomato juice

(xxxiv) We pampered the dog with tomato juice

(xxxv) We advertised the dog with tomato juice

(xxxvi) We fattened the dog with tomato juice

For these reasons, Svenonius (2007: 25-26) considers that *with* may introduce an adjunct, rather than a Figure, and compares it to *by*. The complement of the passive *by* can be interpreted as an agent, a causer, an instrument, an experiencer or a location depending on the predicate:

(xxxvii) Lila was investigated by the CIA

(xxxviii) The window was broken by the storm

(xxxix) This bread can't be cut by an ordinary knife

(xl) This movie is liked by Tolkien fans

(xli) The house is surrounded by trees

Svenonius concludes that prepositions like *by* or *with* do not assign a thematic role to their complement, and that the DP which is apparently in their complement position really originates as an argument of the verb (as in Kayne 2004, Cinque 2002 and Collins 2005). In this sense, he suggests that these prepositions might be actually case-assigners or functional prepositions.

These considerations on *with* are interesting for the discussion. Above, I have suggested that Voice denotes originally a stative subevent which gets different interpretations depending on its complement. The argument in its specifier may be interpreted as a causer, an actor or a holder. Furthermore, it has the function of case-assigning the internal argument, which, in line with what Svenonius observes about *with*, does not originate in its complement position. Thus, Voice and *with* have some similar characteristics; their unspecified semantic interpretation and their case-assigning function to an argument which is not in its complement position.

(see in this respect the fn.110), whereas the meaning denoted by the lower state is always the same. Finally, these two stative subevents are also distinguished by their case-licensing function. The lower state case-licenses its Ground complement, if it is lexicalized separately from it.<sup>111</sup> In contrast, Voice case-licenses the internal argument of the predicate, which is not in its complement position.

#### 7.3.4. Deriving theta roles

The external ergative argument is introduced by Voice. As a central coincidence head, its specifier, gets a HOLDER theta role. However, I have suggested that this only occurs when a *proc* subevent is not present in the event configuration. If *proc* is projected, the external argument is interpreted as an INITIATOR. I suggest that the HOLDER interpretation of the external argument would be, then, a kind of default reading, like the possessor interpretation in possessive constructions.

Nevertheless, there are many more nuances in the interpretation of the external argument which must be somehow accounted for, for example, whether it is a volitional agent or an instrument causer, a psychological experiencer or just a holder. I will follow Ramchand (2008a) in claiming that all this more specific properties of the external argument are derived from (i) the structural presence of the process and result subevents –as noted in section 7.3.2–; (ii) animacy features of the external argument; and (iii) the encyclopedic content associated with the predicates.

Consider the sentences in (30) and (31). In (30), the external argument is a holder and, in (31), it is an actor. The internal argument in (30), *ni* ‘me’, originates in the specifier of a state subevent. Thus, it is in a central coincidence relation with the property *ezagu* ‘known’. The external argument *txakurrak* ‘the dog’, in contrast, has been introduced by Voice. Since *proc* is not projected in between the lower state and Voice, *txakurrak* is interpreted as a holder, and the whole predicate can be paraphrased as *the dog has me in knowledge*.

- (30) Txakurra-k (ni) ezagu-tze-n nau  
 dog-ERG (me.ABS) know-TZE-INE have.3sgERG.1sgABS  
 ‘The dog knows me’

<sup>111</sup> Recall in this sense, the Generalization on Roots (section 4.3.3).

- (31) Txakurra-k korri egi-n du  
 dog-ERG run do-TU have.3sgERG  
 ‘The dog has run’

In the eventive example of (31), in contrast, there is not a lower state, but a *proc* head –lexicalized by *egin* ‘do’ and its PATH *korri* ‘run’ (see chapter 4, sec.4.3.2). As formulated in section 3.2 of this chapter, the fact that there is a process subevent projected below Voice triggers an INITIATOR interpretation of the external argument. In a theta-role system like that of Reinhart’s (2002), where theta-roles are defined by virtue of the combination of two binary features [ $\pm c$ ,  $\pm m$ ], the agent theta role is specified as [+c,+m], where *c* corresponds to *cause change*, and *m* to *mental state*. For instance, predicates like *run* (*korri egin* in (31)) take subjects which are causers but, at the same time, are mentally involved. This cluster of features is derived, in our system, from the presence of Voice and *proc*, and from the absence of *res*. In (31), since *proc* does not select for a state subevent (which would turn into a *res*), *txakurak* ‘the dog’ is understood as an *actor* or an *agent*.

Consider now the following sentences:

- (32) a. Mikel-ek aldizkaria honda-tu du  
 Michael-ERG magazine.ABS damage-TU have.3sgERG.3sgABS  
 ‘Michael has spoiled the magazine’  
 b. Urak egurra hondatu du  
 water-ERG wood.ABS damage-TU have.3sgERG.3sgABS  
 ‘The water has damaged the wood’
- (33) a. Ane-k leihoa apurtu du  
 Ane-ERG window.ABS bit-TU have.3sgERG.3sgABS  
 ‘Ane has broken the window’  
 b. Mailua-k leihoa apurtu du  
 hammer-ERG window.ABS bit-TU have.3sgERG.3sgABS  
 ‘The hammer has broken the window’

In Reinhart (2002), these predicates select for a unary cluster [+c]. This means that the value corresponding to the other feature, namely *m*, is left unspecified. In our system (see section 7.3.2), the projection of both *proc* and *res* makes that the external argument is interpreted as a causer. As in Reinhart (2002), volitionality is not syntactically specified, but it is rather derived from other factors. As a matter of fact, in these two pairs of sentences, *Mikelek* and *Anek* are interpreted as volitional causers, whereas *urak* ‘the water’ is interpreted as a non-volitional causer and *mailuak* ‘the

hammer' as an instrument, even though both pairs of sentences share the same predicates (*hondatu* 'to ruin, to spoil' in (32) and *apurtu* 'to break' in (33)). The specific nuances attributed to the external argument, then, are attributed to the  $\pm$ animate/ $\pm$ human features of the external argument. Thus, humans like *Mikel* and *Ane* can become volitional actors, while non-animate and non-human arguments like 'water' or 'hammer' will be non-volitional and maybe instruments, depending on encyclopedic content and world knowledge.

Regarding experiencers or psych actors, the same explanation can be given. An external argument can be interpreted as an experiencer if it bears the right animacy features and if the predicate has the relevant encyclopedic content.

- (34) Jon-ek *Amelie* filma du gogoa-n  
 John-ERG *Amelie* film.ABS have.3sgERG.3sgABS mind-INE  
 'John remembers the film *Amelie*' lit. 'John has the film *Amelie* in mind'

In this sentence, there is an external argument, *Jone*, introduced in the specifier of Voice. This argument is also interpreted as an *experiencer*, because it is animate and human and because the predicate in which it appears, *gogoan izan* 'to have in mind', has a lexical-encyclopedic content related to the psyche. The same pattern applies to eventive predicates such as *gogoratu* 'remember'.

Therefore, the different specific properties associated to the external argument are derived from the combination of several factors: the presence of a process and a result subevent, animacy features of the argument and the conceptual information related to each predicate.

#### 7.4. IMPLICATIONS FOR SUBJECTS IN INTRANSITIVE K-STATES

In this section, I will study the implications of the nature of the head introducing the external argument for the formation of K-states. As argued in chapter 6, K-states are non-eventive and non-dynamic predicates, which do not involve the projection of *proc*. Now, taking into account that the specifier of Voice is a holder argument when *proc* is not projected, there are actually two positions for holders in stative predicates: the specifier position of Voice and the specifier position of the lower state. The semantic difference triggered by these two generating positions is minimal, in many cases imperceptible. Being generated in the specifier of Voice, the external argument is interpreted as “possessing” the property denoted the predicate. In contrast, being originated in the specifier of the lower state, the internal argument is interpreted as abstractly “being located” in the set of entities having the property. Imagine a predicate like ‘be yellow’. Semantically, it seems quite similar to state ‘x is in yellow’ or ‘x has the property yellow’, since in both cases the entity x has yellow color. Depending on the predicate, the argument is introduced in one way or another, yielding an unergative or an unaccusative structure.

- (35) Jon-ek Jainkoarengan sines-te-n du  
 John-ERG God-INE believe-TZE-INE have.3sgERG.3sgABS  
 ‘John believes in God’
- (36) Zapatak armairu-an kabi-tze-n dira  
 Shoes.ABS closet-INE fit-TZE-INE be. 3plABS  
 ‘The shoes fit in the closet’

In the examples above, the difference between the generating positions of the arguments is somehow more visible. In the predicate *sinestu* ‘to believe’, the external argument possesses the property expressed by the predicate, as *John has the property of believing in God*. In *kabitu* ‘to fit’, in contrast, the property itself is related to a spatial configuration, so that the internal argument is understood to fit that property, as in *the shoes have the property of fitting in the location of the closet*. In other cases, there is no semantic difference at all, and the unaccusative or unergative alignment seems to be almost casual. For example, the predicate *existitu* ‘to exist’ is an unaccusative predicate in standard Basque, but some instances of unergative uses of *existitu* are found in the *Contemporary Reference Prose* and the *Corpus Goenkale* (a

corpus which gathers the texts from a famous Basque tv series) (Sarasola, Salaburu & Landa 2011), without any apparent semantic difference.<sup>112</sup>

- (37) a. Zu-retzat ordea denek existi-tze-n dute, ezta?  
 you-DEST however all-ERG exist-TZE-INE have.3plERG, don't they?  
 'For you, however, they all exist, don't they?' [*Goenkale*, chapter 2044, sec. 10]  
 b. Mirariak existi-tze-n dute, Itxaso.  
 miracles.ABS exist-TZE-INE have.3plERG, Itxaso  
 'Miracles exist, Itxaso' [*Goenkale*, chapter XIX-45, sec.11]
- (38) Horiek zine-an eta nobele-tan existi-tze-n dira, Mluisa  
 those.ABS cinema-INE and novels-INE exist-TZE-INE be.3plABS, Mluisa  
 'Those exist in the cinema and in novels, Mluisa' [*Goenkale*, chapter 1902, sec. 8]

I claim that the difference in subject case and auxiliary selection found in these examples is the result of the unergative/unaccusative alignment of the predicate. In K-states, the introduction of the subject as external or internal does not trigger important semantic differences but, in some languages like Basque, is morphologically visible. The lack of meaningful semantic difference between unergative and unaccusative K-states has been introduced in the prediction on D- and K-states made in (2), repeated here:

- (39) Prediction on D-states and K-states  
 a. D-states must not have an internal subject  
 b. K-states can have either an external or an internal subject

In contrast to intransitive D-states, in intransitive K-states, whether the subject is introduced in [spec, VoiceP] or in [spec, stateP] does not trigger a big semantic difference. Thus, in intransitive K-states, we expect to find both unergative and unaccusative predicates alike. As a matter of fact, intransitive stative predicates are potentially variable cross-linguistically. Sorace (2000 2004) presents an *Auxiliary*

<sup>112</sup> The variability in subject case and auxiliary selection in the predicate *existitu* 'to exist' can be even observed in a sentence by K. Mitxelena (1989):

- (xlii) [Ba, ixkina horretatik pasa arte, bai. Hortik aurrera, ikusten ez zaitudanez gero],  
 [Until passing by that corner, yes. From then on, since I don't see you]  
 ez zara (ez duzu?) "esisti-tze-n"  
 no be.3sgABS (no have.3sgERG) exist-TZE-INE  
 'You don't exist'

*Selection Hierarchy* where classes of predicates are distributed according to their auxiliary selection pattern.

(40) Auxiliary Selection Hierarchy (ASH) (Sorace 2004: 256)

Change of location	Selects BE (least variation)
Change of state	
Continuation of a pre-existing state	
Existence of state	
Uncontrolled process	
Controlled process (motional)	
Controlled process (non-motional)	Selects HAVE (least variation)

With this hierarchy, Sorace (2000 2004) accounts for the delimited and systematic variation found in intransitive predicates with respect to the auxiliary selected. According to Sorace, some predicates are consistent in showing unergative/unaccusative variation across languages and languages varieties, while others are consistently unaccusative or consistently unergative, both synchronically and diachronically. Interestingly, stative predicates are in the middle of the hierarchy, showing that they are the most variable class.

Stative verbs occupy the most variable position on the hierarchy. In contrast with continuation of condition verbs, which incorporate the negation of change in their semantics, verbs denoting simple existence imply no change component at all. This class includes verbs referring to concrete states (*be, exist, belong*), positional verbs in their ‘simple position’ meaning: *sit, lie, etc.*, and verbs denoting abstract or psychological states (*seem, suffice, please*). These verbs are neither externally nor internally caused: the notion of causation is simply irrelevant” (Sorace: 2000: 869).

Note that the stative predicates mentioned by Sorace (2000: 869) are K-states, rather than D-states. This contrast between D-states and K-states receives a natural explanation within the current theory. It is also in accordance with Levin & Rappaport Hovav (2000) who argue that stativity does not play a role in determining the unaccusativity of single argument predicates. Stative predicates can be either unergative or unaccusative, without that supposing a big deal. Eventive predicates –D-states and others–, in contrast, the position of the introduction of the subject has



important semantic consequences (as well as morphological ones). Eventivity involves the projection of the *proc* head (as suggested by Fábregas & Marín 2012). The projection of *proc* triggers a different semantic interpretation of Voice and of the lower state subevent. Voice is interpreted as an initiation subevent, and the lower state as a *res*. Therefore, in eventive predicates the introduction of the argument internally or externally does really matter for the interpretation, but in K-states is not semantically relevant. I claim that this is the reason for eventive predicates being more consistent and showing less cross-linguistic variation.

## 7.5. EVENTIVE/STATIVE ALTERNATIONS AND THE EXTERNAL ARGUMENT

In this section, I will analyze how certain morphemes appearing attached to the predicates affect the semantic interpretation of the external argument. Firstly, I will focus on bare analytic predicates and their eventive (*-tu*) counterparts. Secondly, I will analyze the transition from eventive predicates where the external argument is interpreted as an initiator, to stative predicates where it is understood as a holder. In both cases, the modification of the role of the ergative argument is correlated with the appearance of additional morphological material attached to the predicate.

### 7.5.1. From stative to eventive

#### 7.5.1.1. BARE ANALYTIC PREDICATES AND TRANSITIVE PREDICATION

As I introduced in section 3.3, many stative predicates are lexicalized in Basque in the form of bare analytic predicates. This configuration consists of a bare element –which is independently used in the language as a noun, adjective or an inessive PP– and the auxiliary or a copula. Among these predicates, we find psychological predicates like *maite izan* ‘to love’ and *gorroto izan* ‘to hate’, modals like *behar izan* ‘must’ or *nahi izan* ‘want’, or predicates expressing worth or value, like *axola izan* ‘to matter’, or *balio izan* ‘to cost, to be useful’. Here I repeat some of the predicates listed in section 3.3:

(41) *ardura izan* ‘to matter’, *atsegin izan* ‘to like’, *amets izan* ‘to wish’, *balio izan* ‘to cost, to be useful’, *merezi izan* ‘to deserve’, *nahi izan* ‘want’, *uste izan* ‘to think, have an opinion about’, *zor izan* ‘to owe’, *gogoko izan* ‘to like’, *maite izan* ‘to love’, *gogoan izan* ‘to remember, to know’, *alferrik izan* ‘to be in vain’, *maite izan* ‘to love’, *ezagun izan* ‘to be evident / to know’

- (42) a. Orainak   ardura du                   [Música 2004: 192]  
       present-ERG matter have.3sgERG  
       ‘The present does matters’
- b. Leibstandarte-ko soldadu   izatea       zuen                   amets  
       Leibstandarte-GEN soldier be-TZE-DET have.3sgERG.PST dream  
       ‘He wished to be a soldier at Leibstandarte’                   [Lertxundi 2006: 106]

The fact that stative predicates are lexicalized by means of elements which seem to be nouns rather than “verbs” does not seem to be a bizarre characteristic of Basque. For instance, Bittner & Hale (1995: 82) report that in Warlpiri the verbal category is restricted to dynamic events. Predicates like ‘want’ and ‘know’ are expressed by means of the nominals *ngampurrpa* ‘desirous, wanting’ and *pina* ‘knowledgeable about’. In Basque, ‘want’ is expressed by means of bare elements which are independently used as nouns: *nahi* or *gura* ‘wish’. The categorial contrast observed between eventive and stative predicates may be taken as another indication that the lexical category V does not really exist, and that it is derived from the interaction of the event configuration with viewpoint aspect and/or tense, and from the syntactic context where the predicate is lexicalized (see chapter 8).

In this section, I will comment on some interesting aspects regarding the lexicalization and interpretation of these predicates. With respect to the bare analytic predicates built on inessive phrases (e.g. *gogoan izan* ‘to remember, to know’), I claim that it is the inessive adposition itself the element lexicalizing the state, since the inessive denotes a central coincidence relation.

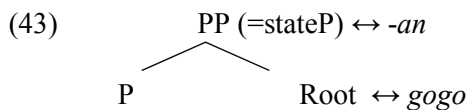

In the case of bare predicates consisting of adjectives, like *maite izan* ‘to love’, the LI *maite* ‘loving’ lexicalizes both the Root and the State. *Maite* is a Property naming Root, and as such, it merges with a state subevent.

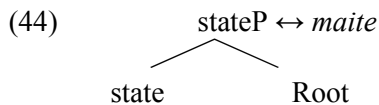

On the other hand, the Root of certain bare stative predicates is not Property naming, but Event naming, like for example *amets* ‘dream’ in *amets izan* ‘to wish’ and *aitor* ‘confession, admission’ in *aitor izan* ‘to confess, to admit’. Someone may think that these predicates are really eventive, but they are not. In the present simple, they have a non-progressive and non-habitual reading, and are incompatible with event-related manner or locative adverbials.

- (45) a. *aitor*    *du*            [gaizki egin duela]            *Non-progressive/*  
           confession have.3sgERG [he did wrong]            *non-habitual*  
           ‘he admits he did wrong’            [Elhuyar]
- b. *askatasuna dute*    *amets*                            *Non-progressive*  
           liberty ABS    have.3plERG dream                            *non-habitual*  
           ‘they dream of liberty’, lit. ‘they have liberty as a dream’ [Elhuyar]
- (46) a. (#*etxe-an*) *aitor*    *du*            [gaizki egin duela] (#*lasai-lasai*)  
           (#home-INE) confession have.3sgERG [he did wrong]            (#calmly)  
           ‘he admits (?at home/calmly) he did wrong’
- b. (#*ohe-an*) *askatasuna dute*    *amets* (#*lasai-lasai*)  
           (#bed-INE) liberty.ABS    have.3plERG dream (#calmly)  
           ‘(?in bed), they dream of liberty (?calmly)’

Thus, it seems that, even though some Roots are Event naming, they do not trigger an eventive reading of the predicate. This is because these Roots are not merged with *proc*, in contrast to other instances of the same Roots (e.g. *amets egin* ‘to dream’ or *aitortu* ‘to confess’) where the *proc* head is projected.

Nevertheless, and coming back to the lexicalization of bare stative predicates, I cannot suggest that the LIs spelling out the Event naming Root (*amets* ‘dream’ and *aitor* ‘confession, admission’) are lexically specified to spell out a state. In the lexical entry of these LIs, there cannot be a stored tree containing a state node. It seems, then, that a Root is interpreted as a state by default. It may be that if a Root is not combined specifically with a process or a state subevent, its default interpretation is one of a state. In this case, the Roots will not surface as a nominal and will not need to be case-licensed, according to the Generalization of Roots made in chapter 3:

(47) Generalization on Roots

Roots need to be case-licensed if they are lexicalized separately from their respective subevent.

The Generalization on Roots presupposes a context where a subeventive node is present. If there is no subeventive structure, like in bare analytic predicates, the Roots do not surface as nouns. This is in accordance with certain empirical facts, already commented in section 3.3. Bare analytic predicates can appear with internal and external arguments.

- (48) a. *Justizia eta zuzenbidea maite ditu*  
 justice and law.ABS love have.3sgERG.3plABS  
 ‘He/she loves justice and law’ [Elizen arteko biblia 2004: Sal 33,5]
- b. *Gorroto dut gerra* [B.Atxaga 2003: 81]  
 hatred have.3sgERG.3sgABS war.ABS  
 ‘I hate the war’

The internal arguments are assigned absolutive case and are cross-referenced in the auxiliary by absolutive agreement morphemes. Thus, the Root associated with the state does not seem to necessitate case. If that were the case, there would not be a case-licensor available for it, since Voice has already case-assigned the internal argument.

In bare analytic predicates where a stative subevent is not specifically projected, like in *amets izan* ‘to wish’, I propose that the internal argument is the subject of a small clause formed with the Root. A similar analysis has actually been proposed by Etxepare & Uribe-Etxebarria (2012) for the modal *behar* and transitive predication structures. Transitive predication structures had previously been reported by Rebuschi (1984) and de Rijk (2008), and have also been addressed in Fernández & Rezac (to appear). Transitive predications consist of “a transitive structure with \**edun* auxiliary as a copula expressing predication” (de Rijk 2008: 675). In these structures, there are two arguments: a theme of predication and a kind of affected or experiencer argument. The predicated theme appears in absolutive case, while the affected argument is marked ergative. Both are cross-referenced in the auxiliary by the corresponding agreement morphemes. Regarding the copula, instead of *izan* ‘be’, \**edun* ‘have’ is selected.

- (49) a. *egilea-k lagun du [liburuan omentzen duen] Julio Cortazar*  
 autor-ERG friend has [who honors in the book] Julio Cortazar  
 ‘Julio Cortazar, who is honored in the book, is a friend of the author’  
 [Berria, 2006-04-04]
- b. (Hark) *eskultore-a du aita* [Berria, 2004-05-26]  
 (he/she.ERG) sculptor-DET has father  
 ‘His/her father is a sculptor’
- c. (Hark) *ezagun-a du baserria* [Cillero, 1998: 187]  
 (he/she.ERG) known-DET has farmhouse-DET  
 ‘He/she knows the farmhouse’, lit. ‘The farmhouse is known to him/her’

I propose, following Etxepare & Uribe-Etxebarria (2012), that in transitive predication, the predicate –which can be a Root (e.g. *lagun* ‘friend’) or a DP

(*eskultorea* ‘sculptor’ and *ezaguna* ‘known’)– forms a small clause (SC) where the predicated theme occupies the subject position. Etxepare & Uribe-Etxebarria (2012) suggest that the external argument is generated outside the predicative relation by an independent adpositional head that they assimilate to an applicative function word. As they point out, the fact that the transitive auxiliary does not directly select the theme of the predication (despite the fact that it agrees with it) is proved by the lack of possessive entailment. For instance, a sentence such as (49c), *hark ezaguna du baserria* ‘the farm house is known to him/her’ does not imply *hark baserria du* ‘he/she has the farmhouse’ (50).

- (50) Hark        baserria        du  
       he/she.ERG farmhouse-DET has  
       ‘He has a farmhouse’

Thus, the external subject does not possess the theme, but otherwise, the subject is within a relation which involves the whole SC. The external argument is an interested or an experiencer argument of the whole predication. Basing on this, Etxepare & Uribe-Etxebarria (2012) argue that the theme the predication is about is in a SC with the predicate, and that the external argument is introduced outside the SC.

As commented before, I claim that the external argument is introduced by a stative head labeled Voice. Since transitive predication structures, as well as stative bare predicates, do not involve the projection of *proc*, the external argument introduced in spec, VoiceP] is interpreted as a mere holder. The holder role may get more specified by means of additional factors, such as the [ $\pm$ human/ $\pm$ animate] nature of the argument or the encyclopedic content of the LI (see section 7.3.4). In the predicates where the LI is associated with a psychological state, like in *maite izan* ‘to love’ or *gorroto izan* ‘to hate’, the animate and human external argument is interpreted as an experiencer.

The structure below represents the structure of the transitive predication and of a bare stative predicate like *amets izan* ‘to wish’:

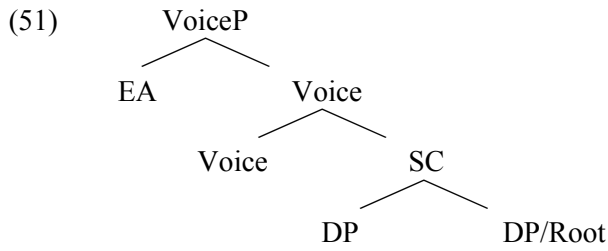

Thus, bare analytic predicates and transitive predication structures consist basically of a similar inner structure, with the difference that transitive predication structures can also be built on predicates consisting on a DP.

#### 7.5.1.2. BECOMING EVENTIVE

Some eventive predicates can be derived from bare analytic predicates. For instance, the eventives *amestu* or *amets egin* ‘dream’ are built on *amets* ‘dream’, a Root also used in bare stative predicates, and *behartu* ‘to force’ consist of the Root *behar* ‘necessity’ also used as a modal or a necessity predicate in its bare form.

Let us begin with the opposition between *amets izan* ‘to wish’ and the eventive *amets egin* ‘to dream’. Consider the sentence in (52a). *Amets* –an Event Root– is the head of a SC, where the CP *libre izatea* ‘to be free’ is in subject position.

- (52) a. *Maialen-ek libre iza-te-a du amets*  
 Maialen-ERG [free be-TZE-DET] have.3sgERG dream  
 ‘Maialen wish to be free’, lit. ‘Maialen has being free as a dream’

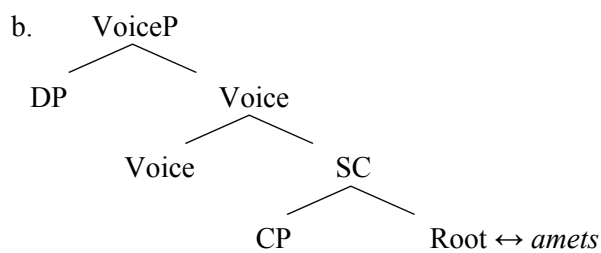

On the other hand, in the eventive predicate where *egin* appears selecting the Root, a *proc* head is projected. Consider the following sentence and its corresponding structure.

- (53) a. *Maialen-ek amets egin du*  
 Maialen-ERG dream do-TU have.3sgERG  
 ‘Maialen has dreamed’

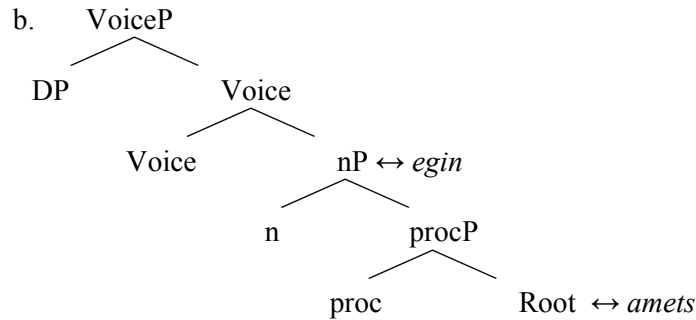

The external argument *Maialenek* has different theta roles, even though in both configurations it is marked ergative case and the predicate consists of the same Root, *amets*. The contrast is motivated by the presence of *proc*. Since *proc* has been projected, the Root has become the Rheme of process, and Voice has been interpreted as an initiation subevent. Furthermore, basing on the formalization of *causer* and *actor* roles made in section 7.3.2, since there is not a *res* projected, *Maialen* is interpreted as an *actor* in (53).

The opposition between *behar izan* ‘need’ and *behartu* ‘to force’ is slightly different. *Behar* is a Property naming Root. In the bare configuration, it can be a modal or a necessity predicate.

- (54) a. *Irakaslea-k arkatz bat behar du*  
 teacher-ERG pencil a.ABS need have.3sgERG.3sgABS  
 ‘The teacher needs a pencil’

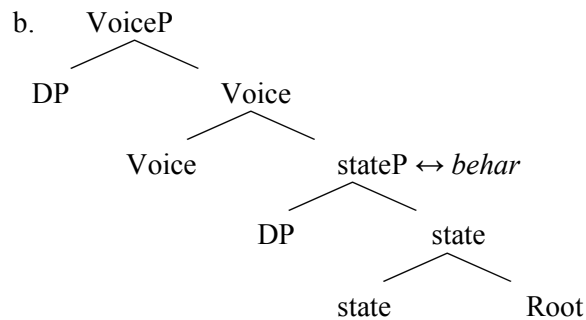



The necessity predicate has an eventive counterpart in Basque: *behartu* ‘to force’. In contrast to the necessity predicate, *behartu* ‘to force’ is a predicate of change of state:

- (55) a. *Irakaslea-k ikaslea behar-tu du*  
 teacher-ERG student.ABS need need-TU have.3sgERG.3sgABS  
 [etxerako lanak egiten]  
 [doing his/her homework]  
 ‘The teacher forced the student [to do his/her homework]’

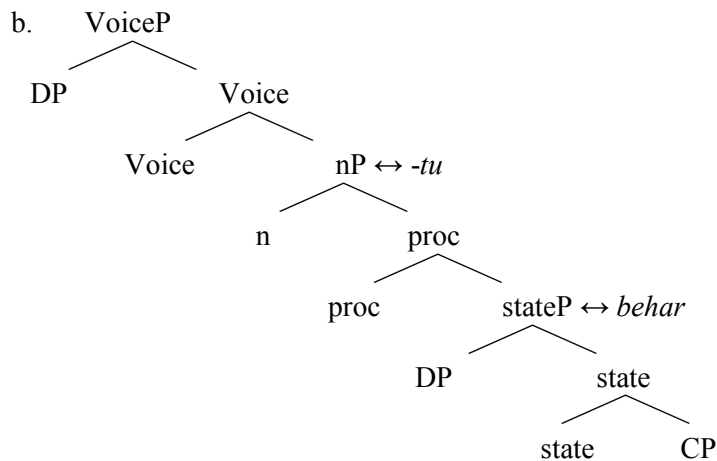

Like in *amets egin* ‘to dream’, the presence of *proc* triggers an eventive interpretation, as well as an initiation interpretation of Voice. Furthermore, since in this case, *res* is also projected, the external argument *irakaslea* ‘the teacher’ is interpreted as a causer, and not as an actor. The difference between *behartu* ‘to force’ and *amets egin* ‘to dream’ is that *behar*, contrary to *amets*, is a State Root, and that its LI also lexicalizes a state subevent. In this way, when *proc* is merged, *behar* spells out a *res* subevent. As can be observed, from this analysis of the data it can be concluded that *-tu*, as well as *egin*, alters the interpretation of Voice and of the external argument, a fact which also provides additional evidence for the separation of Voice from the expression of the event configuration.

### 7.5.2. From eventive to stative: participial transitive predication

Now, I will analyze the opposite path, namely, the transition of an eventive predicate into a stative predicate, and see how this affects the interpretation of the external argument. As we will see, many issues will emerge, concerning precisely the

interaction between viewpoint aspect and the subeventive structure and interpretation of the predicate. More specifically, I will focus on the participial transitive predication, where the predicate is headed by *-tua* (*-tu* plus a determiner) in the form of a resultative adjectival participle.<sup>113</sup>

I have taken the term ‘Participial transitive predication’ from de Rijk (2008: 677-678) (see also Ortiz de Urbina & Uribe-Etxebarria 1991), who actually considers that it constitutes another type of transitive predication. These are some examples of this configuration:

- (56) a. Ama hil-a<sup>114</sup> dut aspaldion [Euskaltzaindia 1997 [1987]: 82]  
 mother.ABS kill/die-DET have.3sgERG for a long time  
 ‘I have my mother dead for a long time’
- b. Mende erdia joa-n-a dugu [MEIG VIII 98, apud De Rijk 2008: 678]  
 century half.ABS go-TU-DET have.1plERG  
 ‘Half of the century has gone to us’
- c. Begiak nahigabez lauso-tu-a-k ditut [PS 6:8, apud De Rijk 2008: 678]  
 eyes.ABS sorrow-INSTR well.up-TU-DET-pl have.1sgERG.3plABS  
 ‘My eyes are welled up with the sorrow’, lit. ‘I have eyes welled up by the sorrow’
- d. Gizona, barka-tu-a-k dituzu bekatuak  
 man forgive-TU-DET-pl have.2sgERG.3plABS sins.ABS  
 ‘Man, your sins are forgiven’, lit. ‘you have sins forgiven’  
 [Lk 5:20, De Rijk 2008: 678]

The participles of (56) are resultative adjectival participles, formed attaching the determiner *-a* to the *-tu* headed predicates. With the *-a* determiner appearing together with *-tu*, the predicate has a stative interpretation, blurring in certain cases, the agency/direct causation reading of the external argument. As examples, let us discuss the difference between the following sentences.

- (57) a. ama hil dut  
 mother.ABS kill have.3sgERG  
 ‘I have killed mother’

<sup>113</sup> The study of resultative participles is very complex, and it requires a detailed analysis of many aspects which are not going to be considered here, for example, the different types of resultative participles, the selection of auxiliary or copulas, different interpretations arising from their combination with different classes of predicates or modifiers etc. In this section, I just want to make some comments of the influence of the resultative adjectival participle on the interpretation of the external argument, which, as I will show, supports the analysis of the Voice head made in section 7.3.2.

<sup>114</sup> Note that in Basque both the causative *kill* and the unaccusative *die* are conveyed by the same predicate: *hil*. On the other hand, note that *hil* is a *-tu*-less eventive predicate (see section 3.2.3).

- b. ama hil-a dut  
 mother.ABS die-DET have.3sgERG  
 ‘mother is dead (to me)’
- (58) a. aulkiak erreserba-tu ditut  
 chairs.ABS reserve-TU have.3plERG. 3plABS  
 ‘I have reserved the chairs’
- b. aulkiak erreserba-tu-a-k ditut  
 chairs.ABS reserve-TU-DET-pl have.3plERG. 3plABS  
 ‘The chairs are reserved (for me)’ or ‘I have reserved the chairs’

The (a) sentences convey a bounded event. They are achievements (in the sense of Vendler 1957/1967, Dowty 1979): their subeventive structure includes both *proc* and *res*, and the external argument is interpreted as a causer. In contrast, the sentences in (b) do not necessarily denote such a reading. According to Euskaltzaindia (1997[1987]: 82-83), indeed, the sentence in (57b) has a completely different reading from that of (57a). In (57b), the external argument is just the holder or the malefactive of a state: in this case, the holder of “dead mother”. Thus, there is not a process involved there, not at least, a process initiated by the ergative argument. In (58), we find a similar situation. In (58a), the ergative argument is the direct causer or agent of the process of “reserving the chairs”, whereas in (58b), it is also possible to obtain a reading where someone else has reserved them for the ergative argument. The remarkable interpretation differing (58b) from (58a) is that, in (58b), the actual state of the chairs is what is highlighted (“reserved”) while the ergative argument is interpreted as the beneficiary of that state. Therefore, the lexicalization of the determiner head (-a)<sup>115</sup> seems to be influencing the subeventive interpretation of the whole predicate. As a matter of fact, I claim that it spells out a stative resultative head (see also chapter 8), which gives rise to the Perfect of Result (Comrie 1976). In the perfect of Result, the result of the expressed event still holds in the assertion time.

In the following lines, I will argue that the stativizing Asp head actually disrupts the relation between an outer Voice and *proc*, and that this is the reason for interpreting the ergative argument as an experiencer/holder of a stative predicate. Let us analyze the data step by step.

<sup>115</sup> Recall that, as noted in the fn. 87 (section 5.3), the -a suffix here might not be considered a determiner, but a Pred head (see Eguren 2012). In any case, the categorial status of -a is not relevant for the current discussion.

Firstly, I will introduce some general aspects of the study on participles made in Kratzer (2000). According to Kratzer (2000), adjectival participles are headed by an adjectival head which may be merged into the structure at different positions.<sup>116</sup> As a consequence, the resulting participle has different properties, and In this way, she accounts for the different types of adjectival participles: phrasal vs. lexical. Phrasal adjectival participles allow modifying adverbs (59a) –unlike bare adjectives (59b)–. These are some examples of phrasal and lexical adjectival participles in German. Phrasal adjectival participles can combine with modifying adverbs, while common adjectives cannot.

- (59) a. Das Haar war ziemlich schlampig gekämmt  
 The hair was rather sloppily combed  
 ‘The hair was rather sloppily combed’  
 b. \*Das Haar war ziemlich schlampig fetting  
 The hair was rather sloppily greasy  
 ‘\*The hair was rather sloppily greasy’

In contrast to phrasal participles, lexical participles, which can be negated by the *un-* suffix, cannot be combined with such adverbs.

- (60) \*Das Haar war hässlich ungekämmt  
 The hair was ugly uncombed  
 ‘\*The hair was ugly uncombed’

She suggests that phrasal participles merge with VP, while lexical participles merge with V. Note that none of them selects for VoiceP, because, according to Kratzer (2000) adjectival participles lack Voice. This would be another differing property between verbal and adjectival participles, since verbal ones do involve Voice.

Later works have accounted for the different types of adjectival participles making use of the decomposition of the verbal phrase into a verbalizer head (*v*) and an acategorial Root (Marantz 1997). Anagnostopoulou (2003), Embick (2004) and Alexiadou & Anagnostopoulou (2008) suggest that, in phrasal participles, the stativizer adjectival/aspectual head can merge with *v*P, and that, lexical participles, in contrast, merge with RootP. Additionally, Anagnostopoulou (2003) and Alexiadou &

<sup>116</sup> In the analysis made in this dissertation, categories do not have substantial syntactic content, thus, the syntactic adjectival status of the participle head is not meaningful. What it is interesting for my analysis is that this head *-a* –a stative resultative head– can be merged at different syntactic levels.

Anagnostopoulou (2008) claim that *resultant* participles (Kratzer 1994 2000) in Greek (61a), contrary to what happens in German (61b), may also merge with Voice and have an agentive reading.

- (61) a. To psari itan tiganismeno      apo tin Maria      *Greek*  
           the fish was fried                by the Mary  
           ‘The fish was fried by Mary’  
       b. \*Der Fisch war von Maria gebraten      *German*  
           the fish was by Mary fried  
           ‘The fish was fried by Mary’

As can be seen, Greek phrasal participles are compatible with *apo* agentive arguments –similar to *by* phrases–.<sup>117</sup> This distribution is not shared by *target* participles, which, according to Anagnostopoulou (2003) and Alexiadou & Anagnostopoulou (2008) can only merge with vP, like German phrasal participles in general.

- (62) Ta lastixa itan (\*akoma) fuskomena apo tin Maria  
       The tires were (still) inflated by the Mary  
       ‘The tires were still inflated by Mary’

The modifier *akoma* ‘still’ forces a target interpretation of the participle. When that happens, the agentive *apo* PP is ungrammatical.

Coming back to Basque, the participles presented in the previous examples, repeated here, are clearly adjectival (Euskaltzaindia 1991[1985]): (i) they agree in number with its corresponding argument; (ii) they can modify a noun, just like any other non-derived adjective; (iii) they can occur as complement of predicates like *eman* ‘to seem’ or *irudi* ‘to seem’ and (iv) they can be the complement of the locative copular verb *egon* ‘to be’.

- (63) Aulkiak erreserba-tu-a-k ditut  
       chairs.ABS reserve-TU-DET-pl have.1sgERG.3plABS  
       ‘The chairs are reserved (for me)’ or ‘I have reserved the chairs’  
       (64) Aulki erreserba-tu-a-k/ gorriak nahi ditut  
           chairs.ABS reserve-TU-DET-pl red-DET-PL desire have.1sgERG.3plABS  
           ‘I want the reserved/red chairs’

<sup>117</sup> See Anagnostopoulou (2003) and Alexiadou & Anagnostopoulou (2008) for more evidence suggesting that resultant participles in Greek select for VoiceP.

- (65) Jauna, zurbil zaude, neka-tu-a dirudizu [M.Etxebarria (J.P.Sartre) 2003: 191]  
 Sir pale are exhaust-TU-DET seem  
 ‘Sir, you are pale, you look exhausted’
- (66) Txanberlain haserre-tu-a zegoen [B.Atxaga 2003: 279]  
 Txanberlain.ABS angry-TU-DET was  
 ‘Txanberlain was angry’

Like Greek resultant participles, I suggest that Basque adjectival participles – particularly resultant participles– combine with Voice. As a matter of fact, they involve an external argument which is apparently identical to that of full inflected predicate (see Euskaltzaindia 1997[1987], Zabala 1993). In what follows, I will analyze the use of the *-tua* adjectival participle, mainly used in north-eastern varieties. The other resultative participles, namely *-tuta* and *-turik* (which are traditionally considered adverbial rather than adjectival, see Euskaltzaindia 1997[1987]) also seem to involve a configuration where the head introducing the external argument (Voice) is present,<sup>118</sup> but are, nevertheless, different from *-tua* in many respects (see e.g. Euskaltzaindia 1991[1985], Zabala 1993). In this section, I am not going to deal with those different participles.

The agentive argument of *-tua* participles may occur in different fashions. In the first one, the external argument is overtly expressed (or as a pro-drop) as an ergative argument which is cross-referenced in the auxiliary (67). This pattern would involve the selection of *\*edun* ‘have’ auxiliary. The second one corresponds to an overtly expressed external argument but without being cross-referenced in the auxiliary (68), in which case the auxiliary is *izan* ‘be’ is selected. Finally, in the third one, the external argument is not overtly expressed, and it has an impersonal reading (69).<sup>119</sup>

<sup>118</sup> I consider that *-tuta/-turik* resultatives are the exponents of a configuration involving Voice, since they occur in sentences where the external argument has agentive interpretation.

(xliv) (ni-k) [pelikula hau ikus-i-ta] daukat  
 (I-ERG) [ film this.ABS see-TU-TA] have.1sgERG.1sgABS  
 ‘I have (already) seen this film (lit. I have these film seen)’

<sup>119</sup> There is another resultative construction that is not considered here, where the external argument takes absolutive case and seems to be the theme of the predication.

(xlv) [(ni) liburu asko idatz-i-a] naiz  
 (I.ABS) book many.ABS write-TU-DET] be.1sgABS  
 ‘I have written many books’ lit. ‘I am written many books’

This type of resultative is not considered here.

- (67) (Ni-k<sub>Δ</sub>) [Δ aulkiak erreserbatuak] ditut  
 (I-ERG) [ chairs.ABS reserve-TU-DET-pl] have.1sgERG.3plABS  
 ‘I have reserved the chairs’
- (68) Liburu hau [Anek idatz-i-a] da  
 book this.ABS [ Ane-ERG write-TU-DET] be.3sgABS  
 ‘This book is written by Ane’
- (69) (Ni-k<sub>□</sub>) [Δ oinak garbi-tu-a-k] ditut  
 (I-ERG) [ feet.ABS clean-TU-DET-pl] have.1sgERG.3plABS  
 ‘My feet are washed’

As can be seen, the latter pattern of the adjectival participle in Basque actually combines with an overtly expressed / cross-referenced ergative argument (marked as *Nik*□ in (69), and with the \**edun* ‘have’ auxiliary. Interestingly, the interpretation of this ergative argument is not agentive or causational, but that of a holder.<sup>120</sup>

Consider now the index-free examples below. These sentences are ambiguous between two interpretations. In the first interpretation, the ergative argument corresponds to the agent of the predicate –like that illustrated in (67). In the second interpretation, in contrast, the ergative argument is interpreted as the beneficiary/maleficiary of the resultant state, which in general terms, I call it *holder*. The agent of the predicate, which is not overtly expressed, as in (69), has an impersonal reading.

- (70) a. Autoa konpon-du-a dut [P. Goenaga, apud De Rijk 2008: 678]  
 car.ABS fix-TU-DET have.1sgERG.3plABS  
 ‘I have fixed the car’ or ‘My car is fixed’

<sup>120</sup> That only resultant participles are fine with Voice is supported by the fact that when adjectival participles are combined by *oraindik* ‘still’, the agent reading of a sentence such as (67) disappears and that the ergative marked argument in a sentence such as (68) is ungrammatical. The only reading that an ergative argument can have when an adjectival participle is accompanied with *oraindik* ‘still’ is that of a holder.

- (xlv) (Nik) aulkiak erreserba-tu-a-k ditut DP<sub>ERG</sub> = holder/agent  
 (I-ERG) chairs.ABS reserve-TU-DET-pl have.1sgERG.3plABS  
 ‘I have reserved the chairs’
- (xlvi) (Nik) aulkiak oraindik erreserba-tu-a-k ditut DP<sub>ERG</sub> = holder/agent  
 (I-ERG) chairs.ABS still reserve-TU-DET-pl have.1sgERG.3plABS  
 ‘I still have the chairs reserved’
- (xlvii) Puxikak (\*Ane-k) puztu-a-k dira oraindik  
 balloons.ABS (\*Ane-erg) inflate-TU-DET-pl be.3plABS still  
 ‘The balloons are still inflated (\*by Ane)’

Since the differentiation between resultant and target adjectival participles is not relevant for the current discussion, I will leave it aside. It is nevertheless interesting to see that Basque behaves actually like Greek in this sense.

- b. Garbi-tu-a-k    ditut                                    oinak [Sg 5: 3, apud De Rijk 2008: 678]  
 clean-TU-DET-pl have.1sgERG.3plABS feet.ABS  
 ‘I have washed my feet’ or ‘My feet are washed’
- c. Txartela    eska-tu-a    dut                                    [TOE II, 155, apud De Rijk 2000:678]  
 ticket.ABS request-TU-DET have.1sgERG.3sgABS  
 ‘I have requested a ticket’ or ‘My ticket has been requested’

Now, compare these examples with those of (71). In (71), the predicate is just headed by *-tu*, and the ergative argument is necessarily interpreted as the agent of the predicate. Contrary to the examples in (70), they are not ambiguous.

- (71) a. Autoa    konpon-du dut  
 car.ABS fix-TU have.1sgERG.3sgABS  
 ‘I have fixed the car’
- b. Garbi-tu ditut                                    oinak  
 clean-TU have.1sgERG.3plABS feet.ABS  
 ‘I have washed my feet’
- c. Txartela    eska-tu    dut  
 ticket.ABS request-TU have.1sgERG.3sgABS  
 ‘I have requested a ticket’

The holder interpretation of the ergative argument also takes place in unaccusative predicates, which, I suggest, do not involve the projection of the Voice head:

- (72) a. Mende erdia    joa-n-a    dugu                                    [MEIG VIII 98, apud De Rijk 2008: 678]  
 century half.ABS go-TU-DET have.1plERG  
 ‘Half of the century has gone to us’
- b. Eroria    dut                                    bihotza                                    [Elizen arteko biblia 2004: Jr 8,18]  
 fall-TU-DET have.1plERG heart  
 ‘My heart is fallen’
- c. Bigarren maileko finala-rat    hel-du-a    dugu                                    Galarza VI  
 second level final-TERM arrive-TU-DET have.1plERG Galarza VI.ABS  
 ‘Galarza VI is arrived to the second level final (which benefits/interests  
 you/us/them)’                                    [Herria, 2005-05-19, 19]

The analysis that I propose is the following. I claim that the *-a* determiner spells out a stative resultative head (Asp<sub>RES</sub>). This head can be merged above Voice or below, and depending on where it is projected, the argument projected in [spec, Voice] gets a different interpretation. When Voice is merged to the nP above procP, and Asp is merged to VoiceP, the argument in the specifier of Voice is interpreted as an initiator, because Voice is not in a relation with *proc*, but with the stative head.



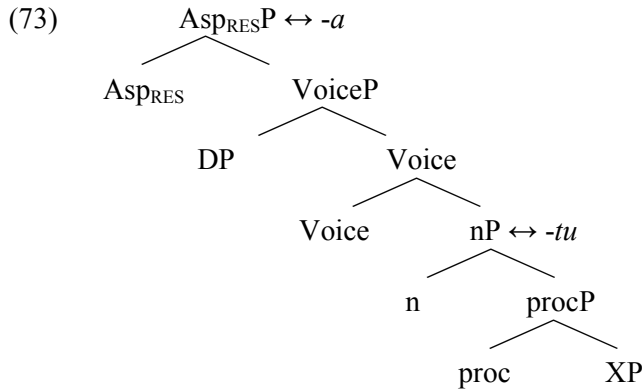

In contrast, when  $Asp_{RES}$  is merged below  $Voice$ , the argument in [spec,  $Voice$ ] is interpreted as a holder because  $Voice$  is not directly related to *proc*. The  $Asp_{RES}$  is the head of a small clause, a predication construction where the subject position is occupied by the internal argument.

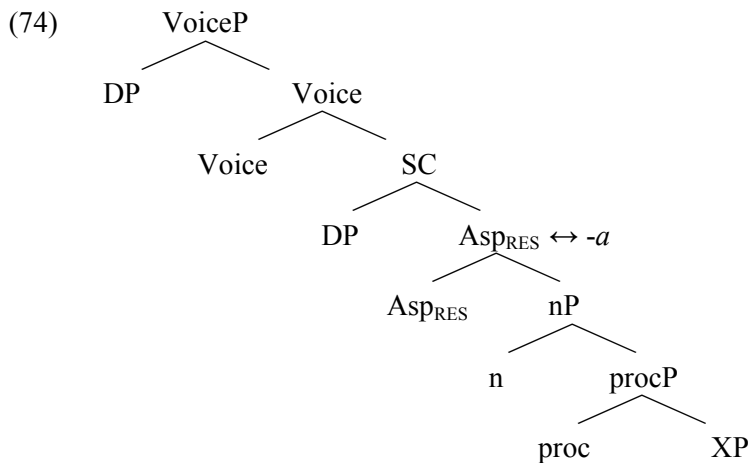

In this configuration, another  $Voice$  head can be projected within the SC headed by the stativizer head, a fact which suggests that this configuration may be bi-clausal (see Ortiz de Urbina & Uribe-Etxebarria 1991). The fact that, in some cases, there are actually two  $Voice$  heads can be transparently observed, e.g.:

- (75) (Ni-k) liburu hori [idazlea-k dedika-tu-a] dut (Zabala 1993: 377)  
 (I-ERG) book that.ABS [writer-ERG dedicate-TU-DET] have.1sgERG.3sgABS  
 ‘I have that book dedicated by the writer’

In (75), both the holder argument (*nik* ‘I’) and the agent argument (*idazleak* ‘the writer’) are overtly expressed. The agent ergative argument (*idazleak*) is related to the process subevent involved in the predicate, while the holder (*nik*) is related to the stativizer *-a*.

Remarkably, note that this dissociation between initiation and ergativity also occurs in unaccusative predicates which do not consist of Voice (72). In those examples, the “lower” Voice is not projected, and  $Asp_{RES}$  selects directly for nP. In any case, the outer Voice cannot directly relate with the process subevent contained in the predicate, because  $Asp_{RES}$  is projected in between, and, therefore, the ergative argument is interpreted as a holder.

All in all, this brief immersion onto resultative adjectival participles has provided additional evidence for my characterization of the head introducing the external ergative argument in Basque. Depending on the type of the following subevent –a state or a process– the head introducing the external argument is interpreted as a state or as initiation.

## 7.6. CONCLUSION

In this chapter, I have analyzed the relation between the head introducing the external argument and the *proc* subevent, which, following Fábregas & Marín (to appear), I suggest it provides eventivity. I have correctly predicted that D-states must be unergative or transitive, and that, importantly, must lack an internal subject. This is derived from the fact that if an internal subject –originated in the specifier of a lower state– is combined with eventivity –*proc*– it becomes a RESULTEE, and the entire predicate gets a change of state meaning. In contrast to D-states, I have proposed that K-states can be either unaccusative or unergative, since *proc* is not present and the introduction of the subject in [spec, VoiceP] or in [spec, stateP] does not alter the dynamicity of the predicate. This was actually confirmed in Basque and cross-linguistically. According to Sorace (2000 2004) stative predicates are the most variable ones, both across languages and across language varieties.

In order to motivate this prediction on D- and K-states, I have previously characterized the head introducing the external argument: Voice. The external argument, marked ergative in Basque, appears alike in eventive and stative predicates and it can be either a causer, an actor or a HOLDER. Building on the characterization of the initiation subevent made in First Phase Syntax (Ramchand 2008a), I have suggested that Voice has basically a stative meaning and that it introduces a holder. Crucially, when *proc* is projected in the event configuration, Voice will be interpreted as an initiation subevent and the argument in its specifier as an INITIATOR.

Thus, in this chapter, I have suggested that the head introducing the external argument is basically a state. However, I have argued that it is different from the state subevent below process (the lower state) namely in two aspects. Firstly, Voice has a context-dependent meaning, which means that its interpretation depends on the whole predicate. Secondly, it case-licenses an argument which is not in its complement position, but, instead, is within the *proc*P or the *state*P lexicalized by the predicate. The lower state, in contrast, has a more fixed interpretation. It introduces subjects which will always be the holder of a state, be it a mere state, or a result state. On the other hand, it is lexicalized by the expression corresponding to the event configuration and it case-licenses its complement (when its complement needs to be case-licensed).

Finally, in the last section of this chapter, I presented some supporting data in favor of this characterization of Voice. I showed that some originally stative predicates –

some bare analytic predicates– become eventive when they are combined with *-tu* or *egin*, LIs which, in chapter 3 and chapter 4, have been claimed to spell out *proc*. The ergative argument, which is a HOLDER in the stative predicate, changes its interpretation and becomes an INITIATOR –either an actor or a causer, depending on the predicate. In this way, I proved that the projection of *proc* below Voice actually triggers a change of interpretation of the external argument. Then, the opposite path has been also explored: the case of adjectival participles. In this context, an originally eventive predicate is combined with a stative resultative head (see also chapter 8) and the whole predicate becomes stative. If an outer Voice selects for the adjectival participle we get a structure called by de Rijk (2008) “participial transitive predication”, similar to the transitive predication but with the difference that the DP predicate is actually a participle. I have shown that, in those cases, the relation between the outer Voice and the *proc* head embedded under the adjectival participial is disrupted by the stative resultative head, and as a consequence, the external argument is interpreted as a holder, and not as an initiator.



## **8. Decomposing verbal configurations**



## 8.1. INTRODUCTION

In this chapter, I will deal with the different verbal configurations of Basque and with their aspectual interpretation. Basque predicates can appear in two different forms: (i) in a synthetic configuration, where the agreement morphemes and other inflectional markers are directly attached to the root (1); and (ii) in the analytic configuration, where inflectional morphemes occur attached to the auxiliary and the main predicate is headed by *-tu* (or its variants) (2) or *-tzen* (3), traditionally considered [+bound] and [-bound] aspectual morphemes respectively (Euskaltzaindia 1997 [1987]).

- (1) a. Neskak etxe-ra doaz  
 girls.ABS home-ALL go.3plABS  
 ‘The girls go/are going home’  
 b. Miren-ek erantzuna daki  
 Mary-ERG answer.ABS know.3sgABS  
 ‘Mary knows the answer’
- (2) a. Neskak etxe-ra joa-n dira 23:00etan  
 girls.ABS home-ALL go-TU be.3plABS 23:00etan  
 ‘The girls have gone home at 23:00’  
 b. Neskak etxe-ra joa-n ziren 23:00etan  
 girls.ABS home-ALL go-TU be.3plABS.PST 23:00etan  
 ‘The girls went home at 23:00’
- (3) a. Neskak etxe-ra joa-te-n dira  
 girls.ABS home-ALL go-TZE-INE be.3plABS 23:00etan  
 ‘The girls go home’  
 b. Neske-k jende asko ezagutzen dute  
 girls-ERG people many.ABS know-TZE-INE have.3plERG.3sgABS  
 ‘The girls know many people’

Additionally, in the analytic configuration, the *-tu* predicate can be headed by *-ko/(r)en* in order to form sentences in future tense. This structure will be briefly considered in section 8.7.2.

The use of the synthetic configuration used to be more extended in previous stages of the language (Mounole 2011) but nowadays it only covers a few verbs (Euskaltzaindia 1997[1987], Hualde 2003b), although they are of a high frequency in the language. The synthetic configuration also used to convey a variety of aspectual interpretations, but in contemporary Basque, it is only used in the imperfective. When an eventive predicate (e.g. *joan* ‘to go’ in (1a)) is put within the synthetic configuration, the predicate has been traditionally interpreted as on-going or progressive (Euskaltzaindia 1997[1987]). Nowadays, however, it is also used to convey habitual aspect (Albizu 2001, Alcazar 2002, Garzia 2005). Regarding stative



predicates (e.g. *jakin* ‘to know’ in (1b)), when they are used in the synthetic form, they have a non-habitual/non-progressive but continuous meaning. Thus, nowadays, the synthetic form covers the aspectual interpretations which are usually grouped within the imperfective category (Comrie 1976, Smith 1991/1997).

Regarding the analytic configuration, the aspectual readings vary depending on whether the predicates are headed by *-tu* or *-tzen*, and on the context. When a *-tu* headed predicate is combined with an auxiliary in present tense, it gives rise to the present perfect (2a), yielding the interpretations which are usually associated to the perfect (Comrie 1976). Additionally, *-tu* headed predicates are also used in the perfective category, if the auxiliary is in past tense (2b). In order to obtain a past perfect interpretation, the *-tu* predicate must be combined with an additional morpheme; *-a*, *-ta* or *-rik*, which have already been mentioned in chapter 6.

The analytic *-tzen* form (decomposed into *-tze* and the adposition *-n*) is aspectually similar to the synthetic form in that it is also used to convey the aspectual meanings subsumed within the imperfective: habitual, progressive and non-habitual/non-progressive but continuous readings. However, as I will show, it departs from the synthetic in that its more natural reading is habitual, instead of progressive.

Additionally, I am also going to address bare analytic predicates, already mentioned several times throughout the dissertation. These predicates are not headed by *-tzen*, but get an imperfective interpretation:

- (4) Miren-ek Jon maite du  
 Mary-ERG John.ABS love have.3sgERG.3sgABS  
 ‘Mary loves John’

In this chapter, I will make a proposal concerning the aspectual interpretations associated to each of these configurations and their synthetic/analytic form. Concretely, I will argue that the synthetic or analytic form of the predicates is partially related to the aspectual projection responsible for the viewpoint aspect, in line with Laka (1993b), Arregi (2000) and Arregi & Nevins (2012). On the other hand, building on Embick (2000), I will suggest that the predicates which are lexicalized in the local environment of T surface like verbs in a synthetic configuration, whereas if they are spelled out in Asp’s area, they will surface with nominal category and in an analytic configuration. An implication of this proposal is that the majority of what we call “verbs” in Basque is really of nominal category. Only the predicates in the synthetic configuration and auxiliaries will have a true verbal category. Since the verbness of a

predicate is defined in terms of it being lexicalized out of the first phase domain, I will ultimately suggest that the verbalizer *v* (Marantz 1997) does not exist in Basque.

The outline of the chapter is the following. Firstly, I will present some proposals and analyses concerning the synthetic/analytic configuration opposition and viewpoint aspect (sec. 8.2). Then, I will introduce my analysis of analytic and synthetic Basque forms and their interaction with viewpoint aspect (sec. 8.3). In section 8.4, I will focus on configurations where an active Asp is posited to be present, and then, in section 8.5, the configurations where Asp is not contentful and, thus, not projected. In section 8.6, I will consider briefly some interesting diachronic data about the verbal configuration of Basque (Mounole 2011) which relate to the present proposal. Finally, in section 8.7, I will present the main conclusions of the chapter, and, make some short comments on the future/prospective form.

## 8.2. FOUNDATIONS

In this section, I will present the theoretical proposals in which the main claims of this chapter are based. Firstly, I will introduce the proposals made by Embick (2000), Laka (1993b), Arregi (2000) and Arregi & Nevins (2012) about the distinction between synthetic and analytic configurations (Embick's on Latin and Laka's, Arregi's and Arregi & Nevins' on Basque). All analyses coincide in suggesting that, in the synthetic configuration, the predicate raises to the inflectional area around T, and that in the analytic one, it stays below Asp. Furthermore, Embick (2000) suggests that this difference in movement is also the source of the verbal status of the predicate in synthetic forms and of its nominal (=adjectival) status in analytic forms. In the second part of this section, I will concentrate on some proposals which have been made about outer/viewpoint aspect. In most analytic forms of Basque, the predicate is headed by *-tu* or *-tzen*, which traditionally have been considered aspectual morphemes. In the preceding chapters, I have analyzed the role of these suffixes in situation aspect. Now, I will explore the status of these morphemes in the domain of viewpoint aspect, to obtain, this way, a more general picture of them. In order to do so, in the second part of this section, I will introduce, first, some definitions and classifications involving viewpoint aspect, as explained in Comrie (1976) and Smith (1991/1997). Then, I will present the model developed by Demirdache & Uribe-Etxebarria (2000 2004 2005 2014) which conceive of tense and aspect as spatiotemporal predicates with the function of ordering time intervals. This is the model that I will adopt. Finally, I will explain another view of viewpoint aspect, namely, that of Katz (2003), which considers that aspectual operators have the function of turning properties of events into properties of times. As I will show, Katz's (2003) analysis will be helpful especially when I deal with stative predicates.

### 8.2.1. The synthetic vs. the analytic form

Embick (2000) makes a proposal about the synthetic and analytic configuration of Latin within the framework of Distributed Morphology, where, as explained in chapter 1, phonological material is considered to be inserted post-syntactically and has, therefore, no influence in syntax. Embick (2000) proposes that both analytic and synthetic verbal forms of Latin may derive from the same clausal structure. The crucial difference between these configurations is that, depending on its syntactic position, a Root can surface as an adjective or as a verb. More specifically, Embick

suggests that if the Root rises to T, it is assigned a verbal category –yielding a synthetic configuration–, while if it stays in AspP, it surfaces as an adjective –resulting in an analytic form.

He bases his claims on the use of some deponent predicates (e.g. *hortor* ‘to exhort’) which require an analytic configuration in the perfect active (5). This behavior contrasts with the rest of Latin predicates (e.g. *amo* ‘to love’), which have a synthetic form in the perfect active (6) and only require the analytic in the perfect passive (7) (p. 189-191).

- (5) a. \*hortavi  
 b. hortatus sum  
 ‘I (have) exhorted’
- (6) a. amavi  
 ‘I have loved’  
 b. amavisti  
 ‘you have loved’
- (7) a. amatus/amata/amatum sum  
 ‘I was/have been loved’  
 b. amatus/amata/amatum es  
 ‘you were/have been loved’

He claims that the analytic use of deponent predicates in the perfect active shows that the difference between analytic and synthetic configurations does not arise due to different syntactic structures, but to a specific feature, namely [pass], which is either (i) systematically correlated to passive syntax, or (ii) possessed by some Roots, more specifically, the roots of the deponent verbs in question. In the latter case, Embick suggests that the presence of the feature [pass] is totally unrelated to the syntax or semantics of passivization, given that the deponent predicates like *hortor* ‘exhort’ (5) are not different from their active, nondeponent counterparts. Embick adds that, since the feature [pass] on deponent predicates has syntactic consequences, this feature must be visible in the syntax. Consequently, he suggests that (at least deponent) Roots are inserted early.

The feature [pass] blocks the movement of the complex  $\sqrt{(\text{Root})-v-\text{Asp}}$  to T, so that  $\sqrt{v-\text{Asp}}$  remains within Asp, as in (8). In contrast, if the feature [pass] is not present in the Root, the complex  $\sqrt{v-\text{Asp}}$  moves to T, as in (9) (p. 213-214).<sup>121</sup>

<sup>121</sup> *Th* corresponds to the Theme vowel, which Embick assumes it is an instantiation of a position added in the morphology. The Agreement (Agr) node appearing the structure is also added in the morphological component, after the movement of the Root to v and of Asp to T.

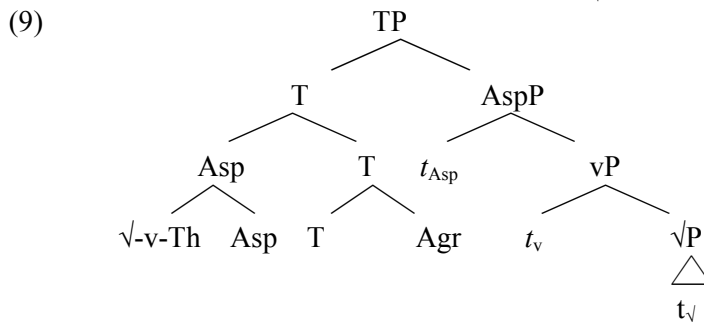
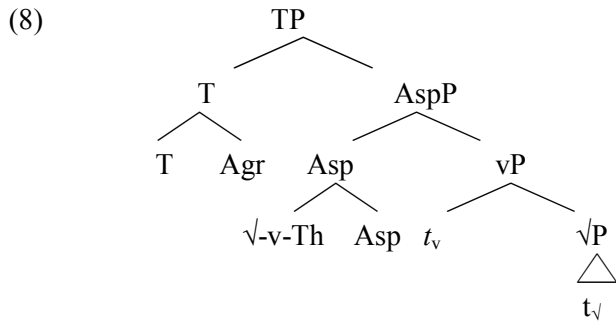

Embick claims that in the former case, the perfect surfaces like an adjective, while in the latter, it is assigned verbal category. The Root of a deponent predicate like *hortor* ‘to exhort’ has the feature [pass], and as a consequence, the complex  $\sqrt{\text{-v-Asp}}$  does not rise to T (8). Thus, the perfect active form of this predicate surfaces with adjectival category. Non-deponent verbs like *amo* ‘to love’, in contrast, do not have the [pass] feature, and the complex  $\sqrt{\text{-v-Asp}}$  moves freely to T in the syntactic derivation. The predicate *amo*, consequently, is lexicalized as a verb (9). Therefore, it is not the case that the adjectival participle *hortatus* (5) has emerged due to an adjectivizing process applied to the verb. He suggests that morphological notions like “adjective” and “verb” in those cases are epiphenomenal; they derive from the syntactic context in which they occur. Thus, he points out that there is not a simple and straight correspondence between lexical category labels like N, V and A(dj) on both syntactic and morphological levels. He claims that the fact that participles are “verbs” surfacing with adjectival category, partially verbal and partially adjectival, is a post-syntactic matter. Following the conception of Roots assumed within DM (e.g. Marantz 1997), Embick assumes that Roots surface with different categories depending on the functional heads in their environment. In this way, he suggests that if a Root is embedded within T (like *amo* in *amavi*), it surfaces with verbal category, and, in contrast, if it is within the environment of Asp (like *hortor* in *hortatus*), it gets adjectival category.

This view of synthetic and analytic forms can be naturally applied to Basque. For instance, Laka, in her (1993b) work on Basque verbal inflection, already suggested that synthetic and analytic forms differentiate precisely in the movement of the verbal complex to T. According to Laka (1993b), the analytic configuration involves no movement of the verb into the inflectional area, while in the synthetic form, the verb rises to Infl. According to her, the difference lies in the presence of the Asp head. Consider the sentences in (10) (Laka 1993b: 29-30).

- (10) a. *ekarr-i nauzu*  
 bring-TU have.2sgERG.1sgABS  
 ‘you have brought me’
- b. *na-kar-zu*  
 bring.2sgERG.1sgABS  
 ‘you bring me’

In the analytic example, the predicate is headed by *-i* (a variant of *-tu*), traditionally considered an aspectual [+bound] morpheme. In the synthetic example, in contrast, the predicate appears directly attached to the agreement morphemes. In the analytic form, agreement morphemes appear in the auxiliary, separated from the predicate. In Laka’s terms, “lexical verbs” in Basque are bound morphemes and need to attach to a base by S-structure. In the analytic configuration, Asp is projected between VP and InflP and provides a base for V. Consequently, V does not raise higher.

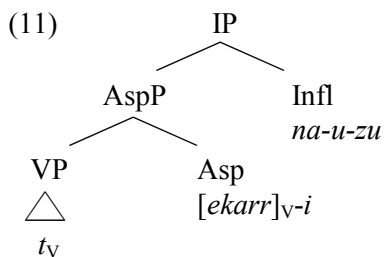

In the synthetic configuration, in contrast, Asp is not projected between Infl and V, and thus, V raises to Infl.

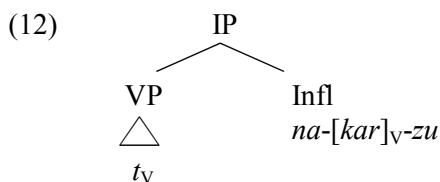

Arregi (2000) and Arregi & Nevins (2012) also account for the differentiation between synthetic and analytic configurations of Basque in these terms. They suggest

that in the analytic form,  $V/v$  cannot raise to  $T$ , because  $Asp$  is in between, and that movement would violate the Head Movement Constraint (Travis 1984). This way, Arregi & Nevins (2012) argue that the auxiliary root in analytic forms is the realization of  $T$ .<sup>122</sup>

In this chapter, I will claim that the synthetic and the analytic configurations are the surface manifestation of a single fact: the lexicalization position of the predicate. Building on Embick (2000), I will claim that if the LI lexicalizing the predicate (in the first phase domain) also lexicalizes a head belonging to the high functional domain, the predicate will have a synthetic form. On the other hand, if the predicate is lexicalized in the complement position of  $Asp$  –in the first phase domain–, the predicate will surface with nominal category and an analytic configuration will emerge. In line with Laka (1993b), I will argue that the projection of  $Asp$  is partially responsible factor for blocking the lexicalization of the predicate in the high functional domain. Generally, if  $Asp$  is present, the predicate will be lexicalized in the complement position of  $Asp$ , whereas if  $Asp$  is not present, it will be lexicalized in the environment of  $T$ , this opposition giving rise to the analytic/synthetic configuration, as commented. In this case, an LI will have to be inserted in  $T$ , in order to provide support for tense and inflectional morphemes: auxiliaries. This is in line with what is proposed in Arregi & Nevins (2012), where auxiliary roots are considered to be the exponents of  $T$ .

As I will show in section 8.5.2, the presence or absence of  $Asp$  is not going to be always determinant for the analytic or synthetic configuration. Some predicates also surface in an analytic form even though  $Asp$  is not present. This is the case of bare analytic predicates, already mentioned throughout the dissertation: predicates which are not aspectually inflected but which are, however, analytic. In those cases, I will claim that these predicates are lexicalized in the first phase domain, below and separated from the high functional domain. I will argue that this happens precisely because they are not lexically specified to spell out a node belonging to the high functional domain. In contrast, they are only specified to spell out the first phase.

An implication of this proposal is that  $v$ , as a “verbalizer” head (Marantz 1997) is not performing its function of verbalizing a predicate, since the surface “verbness” of a predicate is defined by virtue of its lexicalization in the high functional domain, in

---

<sup>122</sup> Arregi (2000), in contrast, suggests that a verbal root is adjoined to  $T$  to form the auxiliary, due to the requirement of the inflection to have a verbal root.

combination with tense and inflectional morphology. An ultimate conclusion following from these facts will be that the verbalizer *v* does not actually exist in Basque.

### 8.2.2. The nature of viewpoint aspect

In previous chapters, I have shown that viewpoint aspect in Basque is closely related to the eventive configuration. For instance, I have shown that some suffixes that have been traditionally considered exponents of viewpoint aspect are actually spelling out heads belonging to the event configuration. In this chapter, I provide an analysis of viewpoint aspect (Smith 1997/1991) in Basque: its different manifestations, interpretations and its syntactic characterization. As advanced in section 8.2.1, I will claim that viewpoint aspect is the key factor in the surface form (and categorization) of Basque predicates.

#### 8.2.2.1. VIEWPOINT ASPECT

I begin by introducing the definition or conception of viewpoint aspect assumed in this chapter. Viewpoint aspect is different from situation aspect in the following way. Situation aspect involves the temporal structure of predicates, and depending on it, predicates are classified into aspectual classes (Vendler 1957/1967). Viewpoint aspect, in contrast, involves the way in which situation aspect is presented in a clause.

Aspectual viewpoints function like the lens of a camera, making objects visible to the receiver. Situations are the objects on which viewpoint lenses are trained. And just as the camera lens are necessary to make the object available for a picture, so viewpoints are necessary to make visible the situation talked about in a sentence. (Smith 1997/1991: 61)

Thus, viewpoint aspect is like a camera which can, depending on the type, focus on different parts of a given situation. Some viewpoints will focus on the resultant state of a situation, others in its internal structure, and, others, will just picture the whole situation. According to Smith (1997/1991), the structure of the situation will affect viewpoint aspect, but both of them must be kept separated.

Comrie, in his monograph on aspect (1976), makes a distinction between perfective, on the one hand, and perfect, on the other. In this chapter, I adopt this



opposition, since it is very useful to explain some Basque data. Perfective denotes a complete (not necessarily completed) situation, with beginning, middle and end. It involves the expression of a situation as a single whole. In this sense, it contrasts with imperfective aspect, which makes explicit reference to the internal temporal structure of the situation. Smith (1997/1991) points out that perfective is informationally closed, because it presents the situation as complete, whereas the imperfective is open, i.e. it does not provide information about the endpoint of the situation. Imperfective aspect, of course, can be subdivided into different categories. In the following diagram (taken from Comrie 1976: 25), I show these aspectual oppositions and the different types of imperfective aspect.

(13) Classification of aspectual oppositions

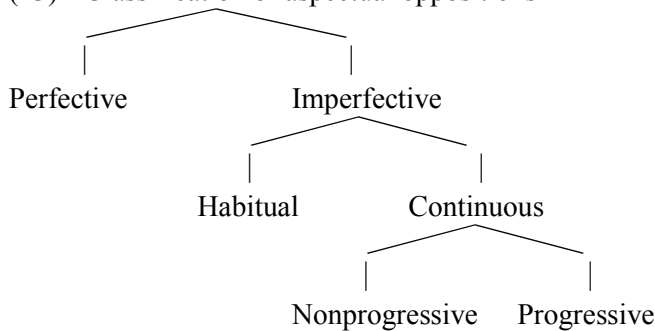

On the other hand, the perfect differentiates from perfective and imperfective forms in that it does not focus on the situation itself, either as a whole or on its internal structure. According to Comrie, it rather relates a state to a preceding situation. Consider the perfective and the perfect sentences below:

- (14) a. I lost my keys  
b. I have lost my keys

Comrie suggests that the in the perfect sentence (14b), there is an implication that the keys are still lost. The perfect somehow denotes the present relevance of a past situation. The perfective (14a), in contrast, does not imply such a meaning. As a consequence, the perfect is viewed as a relation between two times. In the case of the present perfect (14b), the relation holds between a past situation and a present state. In the case of the past perfect (the pluperfect), the relation established involves a past state and an earlier situation.

The perfect can have several interpretations, although not all of them are available in all languages. Additionally, some interpretations are subject to morphological alternations. Comrie lists four possible interpretations associated to the perfect: (i) the

perfect of result; (ii) the experiential perfect; (iii) the perfect of persistent situation (also called the universal perfect); and (iv) the perfect of recent past. The perfect of result, which was mentioned in section 7.5.2, is an interpretation only compatible with telic predicates and involves a state which is the result of a prior situation. As we have seen in the examples in (14), a possible interpretation of the perfect is one in which it denotes a state (the keys are lost) that holds as a result of a past event (the event of losing the keys). On the other hand, the experiential perfect indicates that a situation has held at least once in the interval spreading from some time in the past until the present (assertion time). For example, the sentence in (14b) can have an experiential perfect interpretation if we consider that I have lost my keys at least once in the recent past, but with no implication of having them still lost. This contrast is nicely observed in the pair of sentences below, taken from Comrie (1976: 59):

- (15) a. Bill has been to America  
b. Bill has gone to America

The former has an experiential interpretation: it just asserts that Bill has been, sometime in the past, to America. The latter, in contrast, denotes that Bill is still in the resultant state of the past event: that he is still in America. The latter would be, then, a perfect of result.

The experiential perfect is subject to the felicity requirement that the person must be alive. For instance, a sentence such as (16) is unfelicitous if uttered in 1989, after Einstein's death (Jespersen 1931, Chomsky 1970, Smith 1991/1997):

- (16) Einstein has lived in Princeton

Smith (1997/1991): 108) explains this requirement by means of a felicity condition:

- (17) Felicity condition of the present Perfect

The person to which the subject nounphrase refers must be pragmatically able to bear the property ascribed to them.

On the other hand, the perfect of persistent past or universal perfect is considered the most special interpretation of the perfect. It involves a stative/progressive predicate and has a meaning where the situation started in the past and still holds in the present.

- (18) a. I've lived here for ten years  
b. I've been waiting for hours

Comrie suggests that this interpretation is characteristic of English, and that in other languages, such as French, it is expressed by means of the present simple (e.g. *J'attends depuis trois jours* 'I've been waiting for three days'). Iatridou, Anagnostopoulou & Izvorski (2001/2003) show that the universal perfect is also obtained in Bulgarian, but they specify that it involves the use of the imperfect suffix, rather than the perfective one (see section 8.4.4).

Finally, in the perfect of recent past, the present relevance of the past situation is understood as temporal closeness. This interpretation emerges with adverbs such as *recently* or *just*. Comrie points out that the present relevance does not necessarily imply recentness. It is just enough for a speaker to consider that the past situation is of some present relevance, e.g. a sentence like *the Second World War has ended* can be directed to someone who has been in a desert island incommunicated since 1944, despite the fact that the war has not ended recently. Out of this context, the limit of the use of the perfect for recent situation may vary depending on the language. All in all, the present relevance of the past situation is a common property of all types of perfect interpretation presented so far.

#### 8.2.2.2. Asp AS A SPATIOTEMPORAL RELATION

In this section, I will introduce an analysis of viewpoint Asp (as well as of tense) which considers that Asp is a predicate of spatiotemporal ordering. Demirdache & Uribe-Etxebarria (D&UE onwards) (e.g. 2000 2004 2005), basing on Klein's (1995) proposal, suggest that T and Asp order two times: T orders the Utterance Time (Ut-T) in relation to the time a speaker makes an assertion about (Assertion time, Ast-T) (see also Zagana 1990 and Stowell 1993 2007), and Asp orders the Assertion Time with respect to the time denoted by the VP (Event time, Ev-T). Thus, T and Asp have, each of them, two arguments: T has Ut-T and Ast-T, and Asp has Ast-T and Ev-T. In sum, there are three times that need to be ordered, as proposed by Reichenbach (1947). Both T and Asp order one of its arguments, the Figure, which is a time denoting DP, with respect to the other one, the Ground.

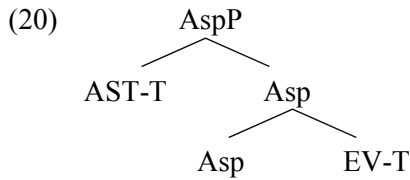
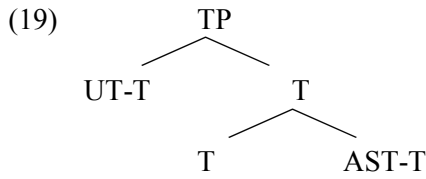

The ordering relation can be of subsequence, inclusion or precedence. These ordering relations give rise to different aspect (21) and tense (22) interpretations, as illustrated:

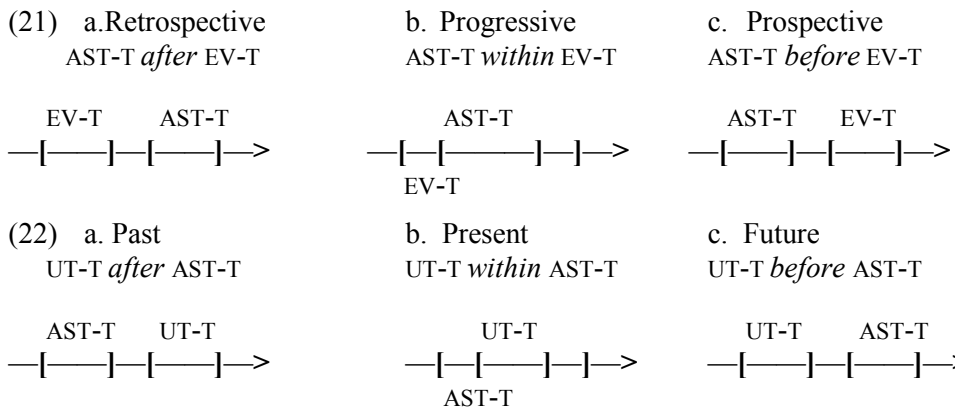

Thus, the ordering relations are defined in terms of a basic semantic opposition: ± central coincidence (Hale 1984). Present tense or progressive aspect is characterized by a predicate of central coincidence (WITHIN), where the location of the Figure (the Ut-T or the Ast-T, depending on TP or AspP) coincides centrally with the location of the Ground (Ast-T or Ev-T). Past tense or perfect aspect is formed by a predicate of [-central, +centrifugal coincidence], where the Figure is ordered AFTER the Ground, or where the trajectory of the Figure is FROM the Ground. Finally, future tense or prospective aspect is defined by means of a predicate of [-central, +centrifugal coincidence], where the location of the Figure is understood to be BEFORE or TOWARDS the Ground.

This characterization of Tense and Aspect makes possible to account directly for the fact that adpositions and predicates denoting different types of ± central coincidence relations are used to build certain aspectual/tense predicates cross-linguistically. Central coincidence adpositions such as *in*, *on* or *at* and predicates of

central coincidence like *stay*, *sit* and *lie* are used to form progressive aspect in many languages. For instance, in Basque, the imperfect morpheme *-tzen*, which is used in the progressive and in imperfective contexts in general, actually consist of the inessive adposition *-n*, as pointed out in several works (Mateu & Amadas 1999, D&UE 2000 and Laka 2004 2006a) and also suggested in chapter 5 and 6.

In this chapter, I will deal mainly with perfect and imperfective aspectual predicates. D&UE (2000 2004 2005) define the perfect aspect as the spatiotemporal predicate AFTER. Thus, in the perfect, Asp is similar to past tense, which is also defined as AFTER. Present and past perfect are distinguished in the spatiotemporal predicate of T, which in the present perfect is WITHIN, and in the past perfect is AFTER. Both phrase structures are illustrated below:

(23) Present perfect

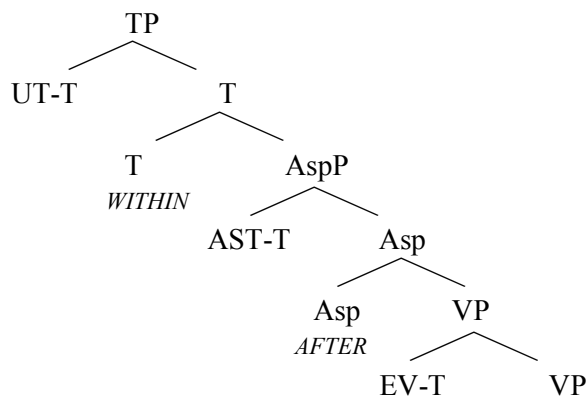

(24) Past perfect

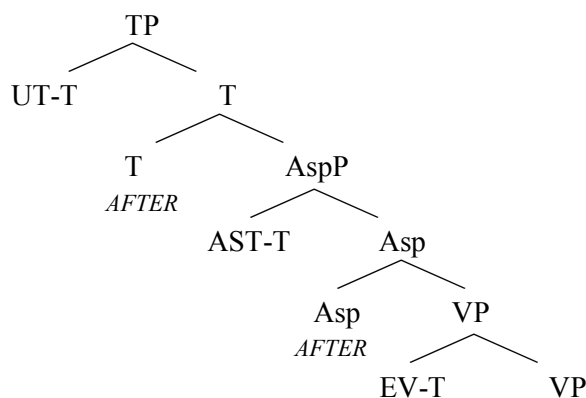

I will follow the characterization made by Demirdache & Uribe-Etxeberria for the perfect. Thus, I will assume that in the perfect, the Asp head picks out a time interval that is located AFTER the interval defined by Ev-T (section 8.4.1).

The analysis of the imperfective and the perfective is slightly different. D&UE (2004 2005 2014) propose that the perfective and the imperfective reading emerge when Asp is morphologically empty. In those cases, the relation between the Ast-T and the Ev-T is resolved in an anaphoric way. The reference of individual denoting noun phrases can be resolved by two anaphoric strategies: covaluation/correference or (variable) binding (Reinhart 1997, Heim & Kratzer 1998 a.o.). D&UE (2014) propose that the reference of time denoting DPs (Ast-T and Ev-T) can also be resolved in that way. If it is resolved through covaluation/coreference, it gives rise to perfective aspect. In such a case, the Ast-T and the Ev-T are assigned the same semantic value, that is to say, the same discourse reference from the discourse storage.

- (25) Amets came  

$$\begin{array}{c} \text{AST-T} \\ \text{---} [ \text{---} ] \text{---} [ \text{---} ] \text{---} \\ \text{EV-T} \qquad \text{UT-T} \end{array}$$

In the sentence (25), T has ordered the Ut-T *after* the Ast-T, giving rise to the *past* tense. On the other hand, Asp is empty, so that the relation between the Event time and the Assertion time has to be established some other way. D&UE (2014) claim that, in this case, the reference of the Ev-T is covaluated with the reference of the Ast-T. Thus, the time of the event of Amets coming is assigned an identical temporal value to that of the time of assertion. In other words, the initial and final bounds of the time span assigned to the Ast-T are also assigned to the Ev-T. This analysis accounts for the fact that the perfective views the event as a whole (Conrie 1976, see section 8.2.2.1).

On the other hand, as stated before, the relation between the Ast-T and the Ev-T can be resolved in a different way: by (variable) binding. D&UE (2014: 8) consider that binding is actually the default strategy to resolve the relation between the Ast-T and the Ev-T. When it is applied, the interpretation obtained is imperfective.

- (26) Amina cries  
 (27) Ast-T  $\lambda_{\text{Ev-T}}$ [Amina cries (Ev-T)]

Binding, unlike covaluation, does not need that the time referents of Ev-T and Ast-T to be identical. According to them, binding is a relation between operators and variables implemented by  $\lambda$ -abstraction. As can be seen in (27), Ev-T is a free variable, which in this case, is bound by a  $\lambda$ -operator adjoined between Ev-T and Ast-

T.<sup>123</sup> The Ev-T variable has to satisfy the property of being a time where ‘Amina cries’ is true. Temporal binding ensures that the time span denoted by Ast-T has to be also a time where the property ‘Amina cries’ holds/is true (p.12). Therefore, according to D&UE, binding merely requires that the Ast-T and the Ev-T temporally overlap/coincide at some point, giving rise to imperfective aspect. Within imperfective aspect, several temporal configurations can be obtained, as illustrated, resulting in on-going or sequential interpretations.

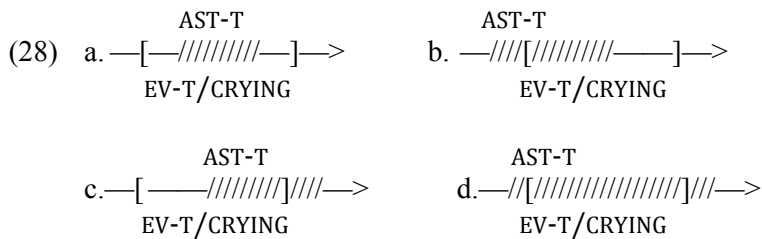

[D&UE to appear: 12]

In these temporal configurations, the Ast-T and the Ev-T coincide at some point. The final bound of the Ev-T may or may not coincide with the time denoted by the Ast-T. Consequently, this temporal interpretation is interpreted as unbounded.

In this chapter, I will adopt this view of the imperfective for the scenario where Asp is not syntactically present, namely the synthetic configuration and bare analytic predicates.

On the other hand, I will show that Basque has a morphologically overt imperfective category, for which case an anaphora account cannot be considered. For this case I will assume that Asp is projected and that it is defined by the spatiotemporal predicate WITHIN (see section 8.4.2).

<sup>123</sup> In D&UE (2014), the syntactic structure of this process is shown (p.12). There, the  $\lambda$ -operator adjoins below Ast-T, in the empty Asp. Thus,  $\lambda$ -abstraction creates a predicate where Ast-T is the external argument.

(29) Morphological imperfective in Basque

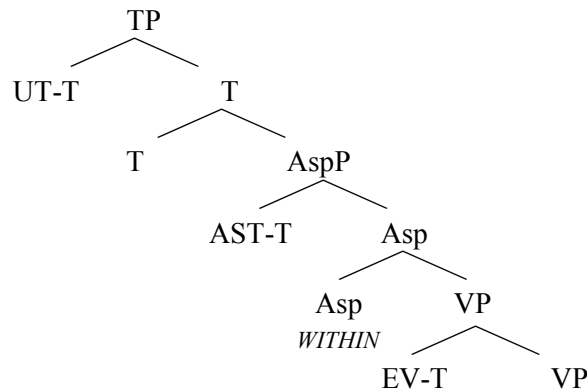

Note, however, that D&UE (2000 2004 2005 2014) posit this exact configuration for the progressive. This seems to be problematic, since the Basque morphological imperfective can actually convey more meanings than the progressive, namely, the habitual and the (continuous) nonprogressive. To resolve the problem of the habitual/progressive, I will claim, building on Ferreira (2005), that, under the effect of WITHIN, the event represented by the predicate can be counted as singular or plural, i.e. as atomic or non-atomic. This atomic/non-atomic ambiguity is obtained by virtue of the projection of a Classifier (Divisor) Phrase (Borer 2005a), which I claim gets lexicalized by the LI *-tze*. By means of *-tze*, the event time introduced by the predicate can be interpreted as consisting of a sequence of event times, and this actually triggers a habitual reading. In this way, the spatiotemporal predicate WITHIN locates the Ast-T as centrally coinciding with the Ev-T, which, this time, represents the sum of all the times denoted by the atomic events it consist of, and will yield an unbounded frequentative interpretation. I formalize the interpretation of frequentative predicates in the following way. Firstly, I define the notion of inclusion, where *i* is a time interval.

(30) *i* inclusion (Ferreira 2005: 96)

An interval *i* is *i*-included ( $\subseteq_i$ ) in an interval *i*' iff the left boundary of *i*' precedes the left boundary of *i*, and the right boundary of *i* precedes the right boundary of *i*'.

Under the projection of Classifier, a given subevent *e* can be interpreted as consisting of several identical subevents. If we assume a homomorphism between the structure of events and their temporal structure, the time of *e* will be equal to the time



of the sum of all subevents of  $e$ . I will indicate that  $e$  consists of several identical subevents notating  $e$  as  $e_{DIV}$ .

$$(31) e_{DIV} \supseteq e_1, e_2, \dots e_n$$

$$(32) \tau(e_{DIV}) = \tau(e_1 \oplus e_2 \oplus \dots \oplus e_n)$$

Now, in the habitual/frequentative interpretation, a time interval introduced by Asp (WITHIN) (the Ast-T), notated as  $i$ , is put within an inclusion relation with the time of  $e_{DIV}$ , which, as formalized in (32), is the time of the sum of all its subevents.

$$(33) \llbracket \textit{Habitual} \rrbracket = \lambda i, \exists e_{DIV} [i \subseteq \tau(e_{DIV})]$$

This analysis is compatible with a view where Asp is seen as the head hosting a [ $\pm$ bound] feature. Since the perfect orders the Ast-T after the right boundary of the Ev-T, the Asp head can also be considered to be a [+bound] head; it selects a time which comes after the final bound of the Ev-T, that is to say, after the event is terminated. This feature, of course, must not be confused with a [+telic] feature. An activity predicate is [-telic], but can be [+bound] if it is headed by the corresponding aspectual morpheme. On the other hand, since the imperfective Asp denotes an inclusion relation between the Ast-T and the Ev-T, where both the initial and final bounds of Ev-T are outside the Ast-T, it follows that the Ev-T is not terminated, so that, it can similarly be considered a [-bound] head.

### 8.2.2.3. Asp AS A STATIVIZER

In this section, I want to come back to an issue already introduced at the end of chapter 7. When I examined the eventive/stative alternations where an eventive predicate turns into a stative one –the case of *-tua* adjectival participles–, I suggested that in those cases, the Asp head –lexicalized by *-a-* has a stativizer function.

In relation to this, operations forming habitual and iterative predicates –as well as operations forming gnomic generics, progressives, modals and negation– have been claimed to be another way of forming stative predicates (Landman & Rothstein 2012a: 87) and that habituais are aspectually stative (Vendler 1957/1967, Katz 1995 2010). For instance, habituais pass a number of tests which are usually restricted to stative predicates. Habituais denote a homogenous event: properties of the subject entity, even though they involve an embedded repetition of an event. A sentence such as *John goes to the mountain* can be paraphrased as *John has the property of going habitually to the mountain*. The repetition of the event ‘go to the mountain’ constitutes a

homogeneous property. It satisfies the *subinterval property* (Benett & Partee 1972): as we have seen before, if it is true that John goes to the mountain at an interval, it is true of all subintervals of that interval, including all the points in the interval. Furthermore, according to Katz (1995: 126), a habitual predicate like *lecture daily* is interpreted simultaneously with an event denoting *when*-clause (Vlach 1981) (34a), does not move narrative time (Dowty 1986) (80b), and gets an epistemic reading with the modal *must*.

- (34) a. John lectured daily when Bill arrived in the city  
 b. John woke up. He lectured daily. So he took a few minutes to prepare his notes.  
 c. John must lecture daily (he is so good at it)

This behavior departs from that of eventive predicates which are interpreted as immediately following the arrival event introduced by the *when*-clause (35a), move the narrative context forward (35b) and get a deontic interpretation with the modal *must* (35c).

- (35) a. Max polished his shoes when I arrived (Katz 1995: 73)  
 b. John got up at 9am. He took a long shower. He made himself a big breakfast and ate it (Katz 1995: 69)  
 c. John must leave now! (Katz 1995: 49)

In this way, habituals show a pattern similar to that of stative predicates such as ‘be here’, ‘be a warm day’ and ‘know’:

- (36) a. Max was here when I arrived (Katz 1995: 73)  
 b. John got up at 9am. It was a warm day. He made himself a big breakfast and ate it. (Katz 1995: 70)  
 c. John must know a lot about rocks. (He has a doctorate in geology)

On the other hand, perfect aspect has also been usually related to stativity. As I introduced in section 8.2.2.1, the perfect is usually characterized as an aspect/tense describing a state that follows from a prior eventuality (e.g. Comrie 1976, Parsons 1990, Vlach 1993, Giorgi & Pianesi 1997). For instance, Alexiadou (2001: 188) states the following about the perfect:

A perfect sentence ‘I have eaten’ is true of a resultant state, a state that holds at a given time if and only if the agent in question is the agent of an eating event that culminated earlier than that time (Alexiadou 2001: 188).

In this sense, Katz (2003) shows that perfect predicates behave as stative predicates and contrast with eventive predicates in a number of tests. On the one hand, they satisfy the subinterval property (Benett & Partee 1972): if it is true that John has gone to the mountain at an interval, it is true at all subintervals of that interval, including all the points in the interval. On the other hand, as Katz (2003) points out, perfect predicates, like *had left* or *had hung sth up* do not advance narrative time (37a), and get an epistemic interpretation with the modal *must* (38a).

- (37) a. The sky was clear. May had left quietly. The washing was on the line. She had hung it up to dry.
- b. The sky was clear. Mary left quietly. The washing was on the line. She hung it up to dry. (Katz 2003: 212)
- (38) a. Mary must have left
- b. Mary must leave

In this section, I want to introduce the view presented in Katz (2003) about the function of viewpoint aspect and its relation to tense and situation aspect. Building on Galton (1984), Löbner (1988) and Herweg (1991), Katz (2003) proposes that events and states are differentiated as follows: state predicates denote properties of times and event predicates properties of events. He considers that tense must combine with temporal properties in order to form propositional meaning. Thus, properties of events must convert onto properties of times in order to enter into a relation with tense. Aspectual operators are considered to be the mediating elements performing this function: aspectual operators turn properties of events into properties of times.

Let us consider the perfect aspect. The perfect has been claimed in some works to consist of two syntactic projections (Iatridou, Anagnostopoulou & Izvorski 2001/2003, Pancheva 2003, Katz 2003): a Perf head below T, and a perfective aspectual operator below Perf.

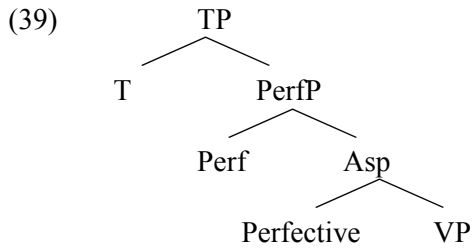

According to Iatridou et al. (2001/2003) and Pancheva (2003), the semantic role of the Perfect head is to introduce an interval, the Perfect Time Span (PTS) and relate it with the reference time, “such that the reference time is its final subinterval” (Pancheva 2003: 285). The role of the perfective aspectual operator, embedded below Perf, as well as of that of the progressive, is to apply to event properties to yield temporal properties (Katz 2003: 216):

- (40) a. Perfective:  $\lambda P \lambda t \exists e [P(e) \ \& \ \text{time-of}(e) \subset t]$   
 b. Progressive:  $\lambda P \lambda t \exists e [P(e) \ \& \ t \subset \text{time-of}(e)]$

These aspectual operators denote reverse relations. The progressive is the inclusion operator and the perfective the included-by operator (Kratzer 1998). Both appear only with non-stative predicates. According to Iatridou et al. (2001/2003) and Pancheva (2003), the Asp head below Perf is specified for viewpoint aspect, as bounded, unbounded or neutral. The bounded Asp head has the semantic effect of setting up the event time as a subset of the reference time (40a). The unbounded Asp head has the opposite effect, setting up the event time as a superset of the event (40b). As stated in the previous section, the position that I take in this chapter is to consider that the unbounded Asp head is defined in terms of the spatiotemporal predicate WITHIN (following D&UE’s model). Regarding the perfective, I will present some considerations in section 8.5.3.

In any case, the function of Asp posited in Katz (2003) is very enlightening. Katz (2003: 217) claims that the perfective operator applies to turn a property of events into a property of times, and this way, it yields a property which can be combined with tense. A stative predicate does not need to be combined with an aspectual operator since it already denotes a temporal property. Therefore, it can be combined with tense straightaway. This conception of Asp will be revealing for some Basque data, as I will show in sections 8.4, 8.5 and 8.6.

### 8.3. DERIVING ANALYTIC AND SYNTHETIC FORMS IN BASQUE

Let us discuss the factors involved in the synthetic *vs.* analytic formation. I suggest that the appearance and categorization of the first phase domain depends on two factors: (i) the presence or the absence of the Asp projection; and (ii) the lexical specification of the predicates.

Firstly, I will discuss the implications of the presence of Asp. Following D&UE (e.g. 2005), I propose that the Asp head orders the Ast-T with respect to the Ev-T. The Ast-T is introduced as the external argument of Asp, and the Ev-T is introduced by the procP. Thus, Asp manipulates an argument of procP, disregarding intermediate projections, namely, VoiceP.

Asp prevents the lexicalization of the predicate in T's area. This may be due to the fact that Asp manipulates the Ev-T introduced by procP, and thus, needs to have procP in its local environment. In any case, when Asp is present in the syntactic structure, the predicate is lexicalized below Asp, and not in T. Building on Embick (2000), I suggest that when this happens, the predicate surfaces with nominal category and the configuration is analytic.<sup>124</sup>

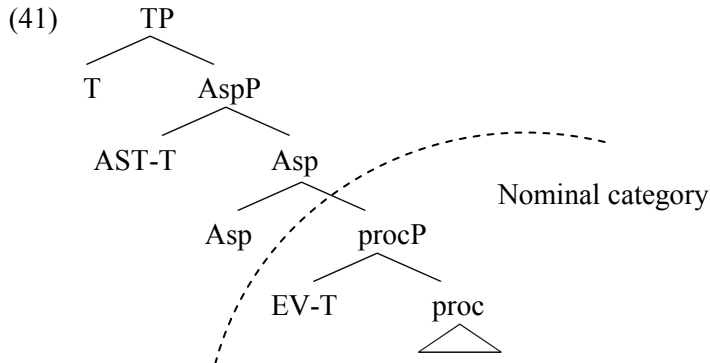

It could be the case the Asp is empty and it is not projected at all. An empty Asp has several syntactic and morphological consequences. To begin with, if a contentful Asp is not projected, the aspectual interpretation of the predicate must be derived some other way. I claim that, in the case of eventive predicates, the reference of the Ast-T and the Ev-T are resolved in an anaphoric way, as suggested by D&UE (2014). In the case of stative predicates in the non-habitual reading, in contrast, I argue,

<sup>124</sup> The structure in (41) is a simplified version of the configuration. As a matter of fact, in imperfectives, I claim that a ClassP is projected above procP.

building on Katz's (2003) proposal that states denote properties of times, that states introduce a state-T, which can be directly combined with the Ut-T introduced by T.

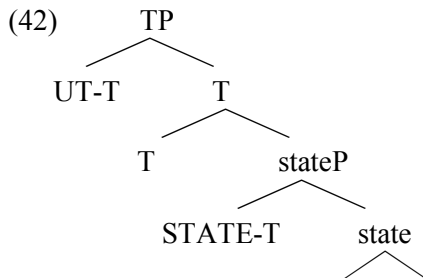

This conception of states will be developed in the following sections.

Coming back to the realization of predicates, I suggest that when Asp is not projected, the predicate is free to be lexicalized in T's area. Here comes the second factor mentioned: the lexical specification of the LIs associated to each predicate.

The agreement morphemes and other tense/mood markers appearing in the inflection surface in Basque attached to a root. In this sense, I adopt Bjorkman's (2011) view of auxiliary insertion which states that auxiliaries are inserted in order to provide support for the inflectional features which have been unable to be realized on the main predicate. For instance, Bjorkman (2011: 89-93) suggests that, in Basque, the auxiliary is inserted in T because T cannot directly Agree with V (due to the presence of non-default Asp in between). As a consequence, the tense features of T are stranded and must be realized by an auxiliary. This consideration is also in line with the view of Basque auxiliaries in Arregi & Nevins (2012), as commented in the previous section.

In the synthetic configuration, there is no auxiliary since the main predicate is providing the necessary support for the inflectional morphemes. I claim that this is possible because, besides not having an Asp head projected, the LIs lexicalizing the predicate in the synthetic configuration are also specified to spell out a head of the high functional area. Assuming the cartographic approach of Cinque (1999 2006), I claim that some predicates can lexicalize heads of the high functional domain, related to modality or aspect, and that are, in this sense "quasi-functional" (Cardinaletti & Shlonsky 2004). This may of course be related to the fact that only a small set of predicates surface in the synthetic configuration in contemporary Basque and that some of them do not conserve the whole paradigm of person combinations. For instance, several predicates are aspectual or have aspectual meanings, like in *ibili* 'to be enganged in', *jardun* 'to be enganged in', *ekin* 'to undertake, to begin', and also

*jarraiki* ‘to continue’, *iraun* ‘to last’ and *eraman* ‘to be, to spend time doing sth’. Others have evaluative or epistemic meanings like *iritzi* ‘to have an opinion about’ or *irudi* ‘to seem’, so that we can think that they actually spell out Mood<sub>evaluative</sub> or Mod<sub>epistemic</sub>. Others are motion and perception predicates, like *etorri* ‘to come’, *joan* ‘to go’, *ikusi* ‘to see’, *entzun* ‘to hear’. Regarding motion and perception predicates, Cardinaletti & Shlonsky (2004) have claimed that these predicates must be regarded as “quasi-functional” predicates, in the sense that they are involved in restructuring configurations, but do not show auxiliary switch like other functional predicates. *Jakin* ‘to know’ is another predicate which can appear in the synthetic configuration, and, interestingly, Cinque (2006: 20) has considered that in its modal or mental ability meaning, it is another instance of a restructuring predicate.

When Asp is not projected, the lexicalization of the predicate in combination with tense and inflectional morphology will depend on the lexical specifications of the LIs. As mentioned above, some LIs are specified with a node belonging to the high functional domain (let be X, where X may be Asp, Mood, Andative etc.), and, others, in contrast, are not. I suggest that the LIs used in synthetic configurations –e.g. *oa* of *joan* ‘to go’ and *to/tor* in *etorri* ‘to come’– have a lexical entry with a stored tree containing the XP node (where X is Andative or Venitive in these cases). On the other hand, the LIs of other predicates, such as *maite* ‘love’ of the predicate *maite izan* ‘to love’ do not contain such a node.

(43) *oa* ↔ </oa/, X, conceptual content>

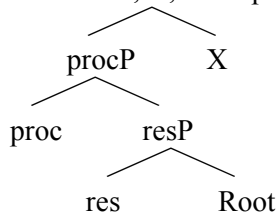

(44) *maite* ↔ </maite/, stateP, conceptual content>

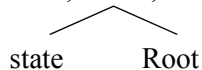

This contrast has a clear consequence in the realization of these predicates. The LI *oa* will lexicalize X, in combination with tense and inflectional morphology, while *maite* will lexicalize only the first phase, in this case, the stateP. *Oa* will surface as a verb and *maite* will be realized as a nominal.

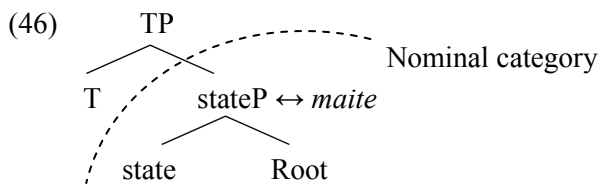
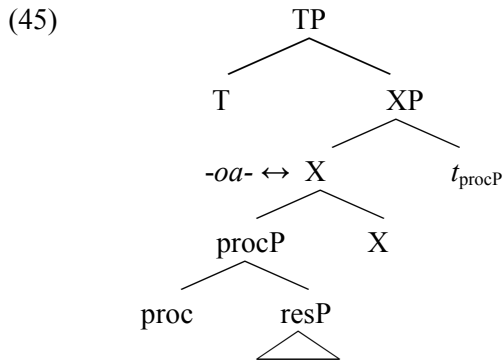

Therefore, in a structure where Asp is empty, two configurations can emerge: a synthetic one (if the LI is inserted in X) (45) or an analytic one (if the LI just lexicalizes the first phase) (46). I claim that the latter case corresponds to bare analytic predicates: predicates which are analytic but which are not aspectually inflected.

Note that within this analysis, there is no need for the presence of a verbalizer head. The verbness property is defined by virtue of being lexicalized in the high functional domain, out of the first phase. In other words, a predicate will surface as a verb if it is lexicalized high, in combination with tense and inflectional morphology, and, thus, the labeling head *v* is not necessary.

On the other hand, the *vP* projection is not necessary in analytic configurations either. Recall that, as I argued in section 5.3, what would look as a *v* in analytic forms (*-tu* and *-tze*) fits much better the nominal category rather than the verbal one. Then, if the LIs *-tu* and *-tze* do not turn a predicate into a verb, but, instead, provide the right context for their complement to be interpreted as a nominal, they must better be regarded as nominalizers, rather than verbalizers. All in all, it seems that we can dispense of *v* and its projection *vP* in order to account for the categorization of predicates in Basque. In the spirit of Embick (2000), the verbal category (VP) may be an epiphenomenal notion, derived from the lexicalization context of the predicate.



## 8.4. ACTIVE Asp

In this section, I will consider two contexts where Asp is morphologically specified and is syntactically projected. Firstly, I will consider the scenario where Asp is defined in terms of the spatiotemporal predicate AFTER, and thus, behaves as a [+bound] head. Secondly, I will address the context where Asp denotes an inclusion relation, as that denoted by WITHIN, and as a consequence, behaves as [-bound] head. In relation to this, I will consider some polysemic predicates which, depending on the nature of the Asp head (AFTER or WITHIN) can have inchoative or stative interpretation. Then, I will discuss the universal interpretation of the perfect, which, in some works (Iatridou et al. 2001/2003, Pancheva 2003) has been suggested to be built on a [-bound] aspectual head, and which in Basque, involves *-tu* headed predicates. Finally, in section 8.4.5, I will make an excursus on the nature of *-tu*.

### 8.4.1. The [+bound] Asp (AFTER)

According to D&UE (e.g. 2005), the perfect aspect consists of an Asp head which can be defined as a spatiotemporal predicate of [-central, +centrifugal coincidence]: AFTER. In this case, Asp introduces a time interval (Ast-T) and locates it *after* the final bound of the Ev-T, as illustrated:

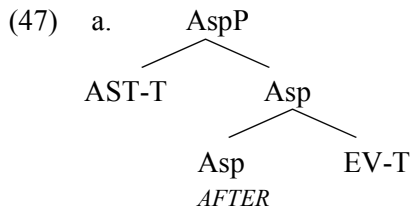

b. AST-T *after* EV-T

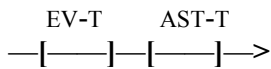

On the other hand, T, in the case of the present perfect, is defined as the predicate WITHIN, which triggers the present tense. In the past perfect (pluperfect), it is defined as AFTER.

(48) a. Present/past perfect

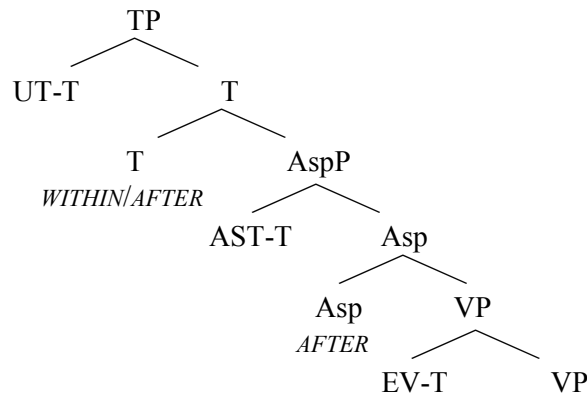

b. Present perfect

AST-T *after* EV-T / AST-T *within* UT-T

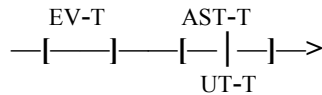

b. Past perfect

AST-T *after* EV-T / AST-T *after* UT-T



Let us recall now the four types of perfect discussed in Comrie (1976) and analyse how they are formed in Basque. As mentioned at the beginning of this chapter, Comrie distinguishes four different interpretations associated to the perfect: the perfect of result, the experiential perfect, the persistent perfect (known as the universal perfect) and the perfect of recent past. Below, I present some Basque examples of the perfect of result, the experiential perfect and the perfect of recent past.

- (49) a. Jon Gasteiz-era joan da (han dago orain) *perfect of result*  
 John.ABS Gasteiz-ALL go-TU be.3sgABS (he is there now)  
 ‘John has gone to Gasteiz (he is there now)’  
 b. Mahaia apurtu-a da/dago  
 table.ABS break-TU-DET be.3sgABS  
 ‘The table is broken’  
 c. Mahaia apurtu-ta/-rik dago  
 table.ABS break-TU-TA/-PART be.3sgABS  
 ‘The table is broken’

- (50) a. Irati-k giltzak gal-du ditu birritan urte honetan  
 Irati-ERG keys.ABS lost-TU have.3sgERG.3plABS two.times this year  
 ‘Irati has lost her keys two times this year’  
 b. Haizea gimnasioa-n egon/-a da  
 Haizea.ABS gym-INE be-TU/-DET be.3sgABS  
 ‘Haizea has been in the gym’
- (51) a. Amets etorr-i berri da perfect of recent past  
 Amets.ABS come-TU new be.3sgABS  
 ‘Amets has recently come’  
 b. Ane-k auresku-a dantzatu du (oraintxe bertan)  
 Ane-ERG auresku.ABS dance-TU have.3sgERG.3plABS (right now)  
 ‘Ane has danced the auresku (right now)’

As can be seen, in most examples, the predicate is headed by the morpheme *-tu*. Furthermore, in the perfect of result and in the experiential perfect, it is also possible to have two morphemes, *-tu* plus the *-a* determiner mentioned in chapter 7 or *-tu* plus *-ta* or *-rik*. In those cases, it is possible to use the locative copula *egon* ‘be’ or *eduki/ukan* ‘have’ instead of the auxiliaries *izan* ‘be’ and *\*edun* ‘have’.

In the previous chapters, I have made several claims about the *-tu* suffix. I have suggested that it represents the nominalizing node (nP), and that in some cases, it may also lexicalize the subeventive head process (Ramchand 2008a). Regarding the examples above, someone could think that it also lexicalizes the Asp head. I will claim that it does not, though. There are two possible ways to account for the [+bound] use of *-tu*: the first one consists in claiming that *-tu* can actually lexicalize an additional syntactic node, AspP, specified as a retrospective AFTER. This would be its lexical entry.

- (52)  $-tu \leftrightarrow \langle /tu/, \text{Asp} \rangle$
- ```

      / \
     Asp nP
    AFTER / \
          n  procP
           |
          proc
  
```

The second option involves positing a phonologically null LI lexicalizing Asp. Within this option, *-tu* would be just spelling out the nP and Asp would be independently lexicalized. A similar proposal has been done by Haddican (2007) and Haddican & Tsoulas (2012), who argue that *-tu* is an infinitive head of nominal category which raises to a phonologically empty Asp head. For the moment, there are no reasons to believe that one explanation is better than the other. Nevertheless, in the

following pages, I will show that *-tu* does not always correlate with an AFTER/[+bound] aspectual head, neither in the analytic configuration. For this reason, I believe that the latter explanation accounts better for the Basque data: in perfect contexts, *-tu* just lexicalizes the node below Asp. As a consequence of being spelled out separately from Asp, *-tu* headed predicates surface as nominals.

Regarding the participle makers *-a/-ta/-rik*, as I show in the examples, these morphemes mostly occur in the perfect of result and in the experiential perfect. Interestingly, these morphemes are necessary in order to form the past perfect –in any interpretation– in Basque. Without them, the sentence is interpreted as perfective (see also sec. 8.5.3).<sup>125</sup>

- (53) a. Mikel joa-n-a zen [iritsi nintzenerako]  
 Michael.ABS go-TU-DET be.3sgABS.PST [by the time I arrived]  
 b. Mikel joa-n-da zegoen [iritsi nintzenerako]  
 Michael.ABS go-TU-TA be.3sgABS.PST [by the time I arrived]  
 ‘Michael had already left when I arrived’ or ‘Michael was gone when I arrived’  
 c. \*Mikel joa-n zen [iritsi nintzenerako]  
 Michael.ABS go-TU be.3sgABS.PST [by the time I arrived]

In the above examples, the past perfect introduces an interval previous to the event of my arriving –also located in the past–, introduced by the second part of the sentence. In those cases, it is necessary to have the *-a/-ta/-rik* morpheme heading the *-tu* predicate. If the *-tu* predicate appears bare (53c), it cannot introduce a state resulting from a previous event, and thus, it cannot serve as the framework for another past event. Recall, in this respect, that the past perfect in Basque can give rise to both perfect of result or experiential perfect interpretations.

- (54) Jon 18:00etan joa-n-a zen  
 John.ABS 18:00-INE go-TU-DET be.3sgABS.PST  
 ‘John had gone at 5pm, and was gone at 6pm’  
 ‘John had gone at 6pm’

The sentence above can have two possible interpretations (see Comrie 1976: 56); the first one involves the result state of the event of going, which still holds at 6pm. This interpretation corresponds to the perfect of result. The second one, in contrast, indicates that John has left at 6pm and does not necessarily imply that the state resulting still holds in the assertion time. These two interpretations are accounted for

<sup>125</sup> Note, however, that the *-tu* + past auxiliary configuration used to have a pluperfect value at earlier stages of the language, as observed by Mounole (2011) in texts dating from the 16<sup>th</sup> century. In this sense, it would be interesting to study the judgements corresponding to the examples in (53) in eastern dialects of Basque.

by considering that the adverbial can modify either the Ast-T or the Ev-T (see D&UE, e.g. 2005: 198-199). In the perfect of result interpretation, the adverbial modifies the Ast-T, and in the experiential one, the Ev-T.

(55) a. the leaving occurs before 6pm

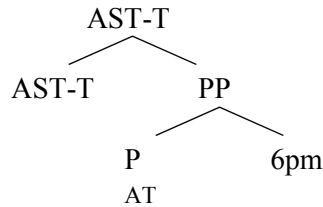

b. the leaving occurs at 6pm

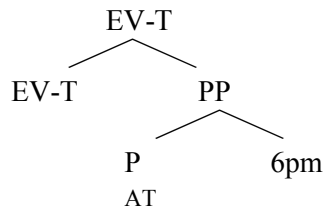

All in all, it seems that the morphemes *-a/-ta/-rik* are lexicalizing the Asp head in these past perfect examples. As a consequence, the lexicalized chunk of *-tu* is reduced to the nP. The same explanation can be given to the resultative and experiential present perfect. The LIs *-a/-ta/-rik* or  $\emptyset$  lexicalize the Asp head and *-tu* spells out only the nP.

(56) Asp  $\leftrightarrow$  *-a/-ta/-rik/∅*

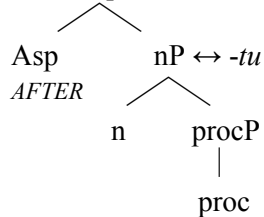

Recall that in chapter 7, sec. 7.5.2, I have argued that *-a* is the exponent of a stative resultative head (Asp<sub>RES</sub>). This can be easily accommodated to the claim that *-a* is also the exponent of an AFTER head. The semantic content provided by the head lexicalized by *-a* would be ‘located after’. Thus, it is a central coincidence (stative) head, but it is specified to be ordered *after* the event time, and this way, it gives rise to the resultative interpretation.<sup>126</sup>

<sup>126</sup> Perhaps, two heads can be posited to be involved here: a state head and an AFTER head. Since this is not crucial for the analysis, I will continue noting that *-a* is the exponent of the Asp head AFTER.

Note that the nP node posited to be lexicalized by *-tu* is only notational. *-Tu* headed predicates surface as nominals, but this is not due to the labeling function of *-tu*, but the lexicalizing configuration of the predicate. In section 8.4.5, I will consider a possible projection that *-tu* may be lexicalizing.

On the other hand, recall that I still have not addressed the persistent or universal perfect. In Iatridou et al. (2001/2003), it has been suggested that the universal perfect involves a [-bound] Asp head. I will leave its discussion for later on (section 8.4.4).

#### 8.4.2. The [-bound] Asp WITHIN

As I already mentioned in a previous section, I take the inessive *-n* of the *-tzen* suffix to be the exponent of the WITHIN Asp head. On the other hand, I consider that *-tze* lexicalizes a Classifier/Divisor head (Borer 2005a), which makes the predicate be interpreted as an atom or as a sum of atoms. This bundle of morphemes is used in Basque in a number of contexts: (i) in habituals; (ii) in progressives; and (iii) in nonprogressive but continuous contexts. All these categories are subsumed within the imperfective category (Comrie 1976).

- (57) a. Maider lan-era joa-te-n da egunero *habitual*  
 Maider.ABS work-ALL go-TZE-INE be.3sgABS. every.day  
 ‘Maider goes to work every day’  
 b. Jonek arropa garbi-tze-n du aste-an behin  
 John-ERG clothes.ABS clean-TZE-INE have.3sgERG.3sgABS. week-INE once  
 ‘John does the laundry once a week’
- (58) a. Eguzkiak distira-tze-n du *progressive*  
 sun-ERG shine-TZE-INE have.3sgERG  
 ‘The sun shines’  
 b. Mikel-ek eskua har-tze-n dio Jone-ri  
 Michael-ERG hand.ABS take-TZE-INE have.3sgERG.3sgABS.3sgDAT Jone-DAT  
 ‘Mikel takes Jone’s hand’
- (59) a. Oso ondo ezagu-tze-n zaitut *nonprogressive*  
 very well know-TZE-INE have.1sgERG.2sgABS */continuous*  
 ‘I know you very well’  
 b. Miren-ek Jainkoarengan sines-te-n du  
 Mary-ERG God-INE shine-TZE-INE have.3sgERG  
 ‘Mary believes in God’

Note that, in Basque, the *-tzen* analytic configuration is most naturally used in habitual and nonprogressive/continuous contexts. The progressive is actually restricted to narrative contexts (58b) (see e.g. Alcazar 2002, Garzia 2005). As pointed out by Garzia (2005), this use of the *-tzen* analytic form is found specifically with those

predicates which lack a synthetic form. In order to form a more natural progressive, *-tzen* would also be used, together with an additional particle: *ari* (see e.g. Laka 2004 2006a).

Apart from those specific narrative contexts, some predicates seem to accept much easier than others the progressive interpretation with *-tzen*. In an out of the blue context, some *-tzen* predicates naturally denote an on-going event. This is actually the case of predicates such as *distiratu* ‘to shine’, *mantendu* ‘to keep’, *zuzendu* ‘to direct’, *kontrolatu* ‘to control’ etc. These predicates, which are represented in the example of (58a), have been analyzed in chapter 5 as D-states. They are eventive but non-dynamic, a characterization which make them behave in some contexts as eventive and in other as stative predicates (see Maienborn 2005, Rothmayr 2009, Fabregas & Marín 2012).

Taking the *-n* adposition as the exponent of the spatiotemporal predicate WITHIN, adopted from D&UE’s model, yields a problem, as commented before: D&UE (e.g. 2005) consider that the presence of the Asp head WITHIN triggers progressive aspect. The Basque *-tzen* morpheme, however, covers all the categories subsumed within the imperfect: apart from the progressive, it is also used in the habitual and in the nonprogressive continuous context. In order to account for the habitual/progressive distribution of *-tzen*, I will make a proposal built on the analysis made in Ferreira (2005) about the habitual and progressive.

Ferreira (2005) explains the the difference between the habitual and the progressive in terms of the quantification of the event. He argues that the imperfective aspect introduces an inclusive relation between time intervals (p.98) and that VPs may denote atomic (singular) or non-atomic (plural) events (p.97). In his terms, number morphemes combine with bare VPs and yield quantified VPs, as illustrated:

$$(60) \quad \text{VP}_{sg} = [\text{sg VP}] \quad \quad \text{VP}_{pl} = [\text{pl VP}]$$

$$(61) \quad [[\text{sg}]] = \lambda P. \lambda e. P(e) \ \& \ e \text{ is atomic}$$

$$[[\text{pl}]] = \lambda P. \lambda e. P(e) \ \& \ e \text{ is non-atomic}$$

$$[[\text{VP}_{sg/pl}]] = \lambda e. [[\text{VP}]](e) \ \& \ e \text{ is atomic/non-atomic}$$

The imperfective category may denote an on-going event or an on-going sequence of (two or more) events. According to Ferreira (2005: 99) this choice depends on whether the imperfective head combines with a singular or a plural VP. Habitual

predicates assert the existence of a plural event of the kind described by the verb phrase, while the progressive asserts the existence of a singular event. Both consist of a time interval which is included in another one: in the case of habituals, it is included in the time denoted by a plural event, and, in the case of progressives, it is included in the time of a singular event.

Taking this approach into our analysis, we can formulate the habitual/progressive opposition in similar terms. I argue that the atomic/non-atomic ambiguity is provided by a Classifier/Divisor head, projected above *procP*. Borer (2005) argues for the existence of such a head in the nominal domain. According to her, without the projection of this head, nouns are interpreted as masses by default. If *ClassP* is projected in contrast, nouns turn into countable things. I argue that the presence of *ClassP* above the first phase makes possible that the event is interpreted atomically or non-atomically. On the other hand, the fact that the whole *ClassP* (embedding *procP*) is lexicalized separately from *Asp* and other high functional heads, results in the surface nominal categorization of the predicate.<sup>127</sup>

Firstly, I will discuss the configuration found in a *-tzen* analytic configuration with a habitual interpretation. Consider the sentence and the tree below:

- (62) a. Jon        mendi-ra        joa-te-n        da  
           John.ABS mountain-ALL go-TZE-INE be.3sgABS. every.day  
           ‘John goes to the mountain’

---

<sup>127</sup> In this sense, there is a nice correlate with nouns: Etxeberria (2014) has argued that bare nouns are number neutral in Basque and that they can make reference to a plurality or a singularity.



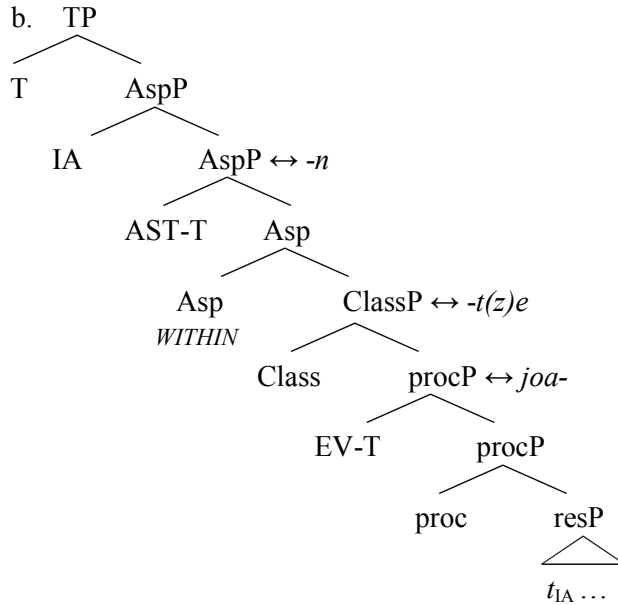

The Asp head *WITHIN* orders the Ast-T *within* the Ev-T, providing a [-bound] feature to the predicate. The Ev-T is introduced by procP, and under the influence of ClassP can be interpreted as non-atomic, that is to say, as consisting of atomic events and their respective Ev-Ts. I repeat here the formulations provided in section 8.2.2.2.

$$(63) e_{DIV} \supseteq e_1, e_2, \dots e_n$$

$$(64) \tau(e_{DIV}) = \tau(e_1 \oplus e_2 \oplus \dots \oplus e_n)$$

$$(65) \llbracket \textit{Habitual} \rrbracket = \lambda i, \exists e_{DIV} [i \subseteq \tau(e_{DIV})]$$

If the event is interpreted as atomic, on the other hand, the projection of the Asp head *WITHIN* triggers a progressive interpretation. As commented, in Basque, there is a very specific context in which a progressive reading is obtained: the *ari + tzen* configuration. Nevertheless, the *-tzen* analytic form can also give rise to a progressive like reading in a narrative context (Alcazar 2002, Garzia 2005), or, in an out of the blue context with certain predicates. In chapter 6, I analyzed a group of predicates which seem to have both stative and eventive-like properties. Following Maienborn (2005 2007), Rothmayr (2009) and Fábregas & Marín (to appear), I have called these type of predicates D-states. One of the eventive tests that these predicates pass is the compatibility with the progressive. Recall that statives are usually assumed to be ungrammatical when combined with the progressive, a property not found in activities and accomplishments (Dowty 1979: 55-56)

- (66) a. \*John is knowing the answer *State*  
 b. John is running *Activity*  
 c. John is building a house *Accomplishment*

D-states, in contrast, are perfectly grammatical in the progressive:

- (67) a. The socks are lying under the bed  
 b. Your glass is sitting near the edge of the table

D-states are different from activities in that they can naturally obtain a non-habitual interpretation in the simple present.

- (68) a. The sun shines *D-state[non-habitual]*  
 b. John runs *Activity[habitual]*

As Fábregas & Marín (to appear) note, the reading that D-states trigger in the simple present is very similar to that obtained in the progressive. Consider, indeed, these Basque examples.

- (69) a. Eguzkiak distira-tze-n du  
 sun-ERG shine-TZE-INE have.3sgERG  
 ‘The sun shines’  
 b. Eguzkia distira-tze-n ari da  
 sun.ABS shine-TZE-INE PROG be.3sgABS  
 ‘The sun is shining’
- (70) a. Jon-ek bere estatusa manten-tze-n du enpresa-n  
 John-ERG his status.ABS maintain-TZE-INE have.3sgERG company-INE  
 ‘John maintains his status in the company’  
 b. Jon bere estatusa manten-tze-n ari da enpresa-n  
 John.ABS his status.ABS maintain-TZE-INE PROG be.3sgABS company-INE  
 ‘John is maintaining his status in the company’

I suggest that D-states headed by *-tzen* must actually be analyzed as progressives. I claim that the difference between habitual and on-going *-tzen* predicates is that, in on-going ones, the event is interpreted as atomic under the influence of ClassP. This interpretation seems to be more marked, restricted to narrative contexts and to non-dynamic D-states.<sup>128</sup>

<sup>128</sup> The lack of dynamicity may be related directly to the atomic interpretation. As argued in chapter 2 and chapter 4, non-dynamic Rhemes (like the Root *distira* ‘shine’) are associated to [–incremental] and [–transitional] measures, where all the points of the measure are exactly the same [+ + + +]. Perhaps, the atomic interpretation of these events under *-tze* is related to the fact that all the points of the measure are the same, and if the event is put in a non-atomic sequence of events, the whole sequence tends to be interpreted as atomic since the beginning and final points of single events are not differentiated.

Finally, I will present the third kind of aspectual interpretation that can be found in the *-tzen* analytic configuration: a nonprogressive/continuous interpretation. This reading is obtained with stative predicates.

- (71) a. Mikel-ek Jon ezagu-tze-n du  
 Michael-ERG John.ABS know-TZE-INE have.3sgERG.3sgABS  
 ‘Michael knows John’  
 b. Jon-ek Jainkoa-rengan sines-te-n du  
 John-ERG God-INE believe-TZE-INE have.3sgERG.3sgABS  
 ‘John believes in God’  
 c. Amets-ek 12 kg pisa-tze-n du  
 Amets-ERG 12 kg weigh-TZE-INE have.3sgERG  
 ‘Amets weighs 12 kg’

Recall the considerations of the stativizing function of Asp made in section 8.2.2.3. According to Katz (2003), events denote properties of events, whereas states denote properties of times. Aspectual operators perform the task of turning properties of events into properties of times, so that they can combine with tense. The predicates in (65) are stative, and according to Katz (2003) denote properties of times. If they are properties of times, they do not need to be combined with Asp in order to be compatible with tense. Within this view, then, it seems that Asp is not performing its usual task in the sentences above. Furthermore, if the Asp head WITHIN were locating the Ast-T within the Ev-t, as it does in eventive sentences, then, it would yield a habitual or a progressive interpretation, and this is not actually the case. I suggest that in this specific case, the head WITHIN, which is a central coincidence head, represents the state subevent. It does not order two time intervals: it orders the internal subject *within* the property denoted by the Rheme (the Root). Returning to Katz’s (2003) terms, WITHIN in this case would not have the function of turning a property of events into a property of times. In other words, it would no longer be an aspectual operator. As a matter of fact, the predicate is already a property of times, so that it can straightaway combine with tense.

- (72) a. Mikel-ek Jon ezagu-tze-n du  
 Michael-ERG John.ABS know-TZE-INE have.3sgERG.3sgABS  
 ‘Michael knows John’

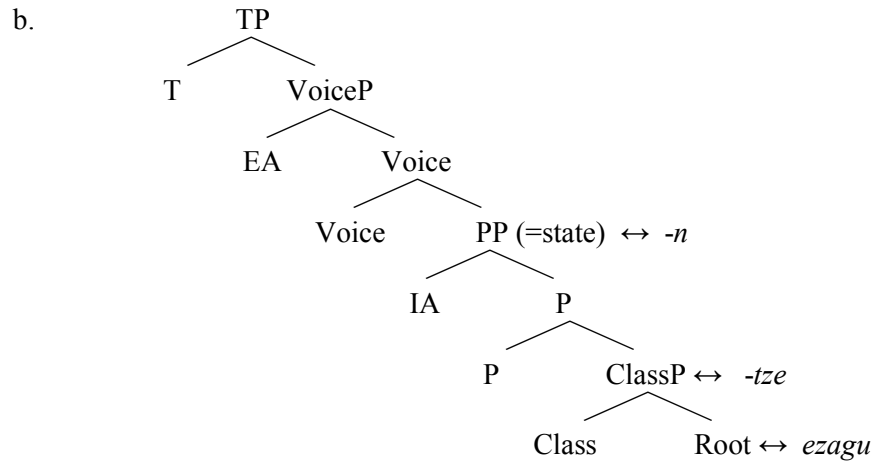

The time introduced by the stative predicate, that we can call state-T, as mentioned in section 8.2.2.2, is directly related to the Ut-T, by T, which in this case, corresponds to the spatiotemporal predicate WITHIN (triggering present tense).

If the Rheme is selected directly by the ClassP (as indicated in (72b)), the Rheme must also be able to have a non-atomic interpretation, and thus, we expect to have a reading where the central coincidence relation is multiple, and the stative predicate is interpreted habitually. For instance, imagine a situation where Jone is a person who knows a lot of people. Every time we go to visit the festivals of other towns, there is always someone who Jone knows.

- (73) [Ondoko herrietako jaietara goazen bakoitzean], Jon-ek beti  
 [every time we go to the festivals of surrounding villages], John-ERG always  
 ezagu-tze-n du norbait  
 know-TZE-INE have.3sgERG.3sgABS someone  
 ‘Everytime we go to the festivals of surrounding villages, John always knows  
 someone’

The same interpretation is observed in the *-tzen* form of copular verbs:

- (74) a. Mutil hori beti ego-te-n da ate aurre-an [ateratzen garenean]  
 boy that.ABS always be-TZE-INE be.3sgABS door front-INE [when I go out]  
 ‘That boy is always in front of the door when we go out’  
 b. [Boligrafo bat behar duzu? Eskatu Joni]. Beti euki-tze-n  
 [do you need a pen? Ask John]. always have-TZE-INE  
 du bat poltsa-n.  
 have.3sgERG.3sgABS one bag-ine  
 ‘Do you need a pen? Ask John. He always has one in his bag’

It seems, then, that the atomic/non-atomic ambiguity triggered by the projection of ClassP has also an effect for stative predicates.

### 8.4.3. Eventive/stative alternation with AFTER and WITHIN

In this section, I will analyze a group of polysemic predicates which have two meanings, a stative one and an eventive inchoative one, depending on whether they are headed by a spatiotemporal predicate AFTER or WITHIN. These predicates are *pentsatu* ‘to think’, *ulertu* ‘to understand’, *ezagutu* ‘to know’, *sinistu* ‘to believe’, *estimatu* ‘to esteem’, *gustatu* ‘to like’, *gogoratu* ‘to remember’ and the perception predicates *ikusi* ‘to see’ and *entzun* ‘to hear’. To my knowledge, the polysemy found in these kind of predicates was first noticed by Vendler (1957/1967), who argued that they can be either states or achievements depending on the context (see also Comrie 1976 and Travis 2010: 139). Interestingly, the eventive/stative variation of these predicates seems to be determined by the spatiotemporal ordering predicate selecting for them: if they are headed by the Asp head AFTER, they are interpreted as eventive, and if they are headed by the head WITHIN,<sup>129</sup> they are interpreted as stative.<sup>130</sup> (cf. Euskaltzaindia 1997[1987]: 157).

When headed by *-tu*, in the perfect configuration with the interpretation of perfect of result, perfect of recent past or experiential perfect, the transitive variants of these predicates become ingressive achievements.

- (75) a. [Lapurreta bat zela] pentsa-tu dut hasieran  
 [that it was a robbery] think-TU have.1sgERG beginning-INE  
 ‘At the beginning, I thought it was a robbery’  
 ‘At the beginning, it occurred to me that it was a robbery’  
 b. Galdera berehala ulertu dut  
 question.ABS immediately understand-TU have.1sgERG  
 ‘I understood the question immediately’  
 c. Jende asko ezagu-tu dut  
 people many.ABS know-TU have.1sgERG.3sgABS  
 ‘I have met many people’  
 d. Jon-en istorioa sinis-tu dut  
 John-GEN story.ABS believe-TU have.1sgERG.3sgABS  
 ‘I believed John’s story’  
 e. Keinu hura estima-tu zuen Robert-ek  
 gesture that.ABS esteem-TU have.1sgERG.3sgABS.PST Robert-ERG  
 ‘Robert thanked that gesture’

<sup>129</sup> Recall the consideration made in the previous section about the head WITHIN in stative predicates. I have suggested that in the case of stative predicates, it cannot be considered an Asp head.

<sup>130</sup> Comrie (1976: 19-20) comments this polysemy is the context of the perfective and imperfective distinction which actually also applies for the opposition analyzed in this section. He notes that in some languages which make this differentiation, the perfective form of some stative predicates gets an ingressive meaning. He cites examples of Ancient Greek, Spanish, Russian and Mandarin Chinese. Smith (1997/1991: 70) also mentions it for Navajo, and Iatridou et al. (2001/2003) for Bulgarian (see next section).

- f. Amets-i bazkaria gustatu zaio  
 Amets-DAT lunch.ABS like-TU be.3sgABS.3sgDAT  
 ‘Amets liked the lunch’
- g. Bapatean zure istorioa gogoratu dut  
 suddenly your story.ABS remember-TU have.1sgERG.3sgABS  
 ‘Suddenly, I remembered your story’

They generally denote an instantaneous event which triggers the beginning of a state: the predicate *pentsatu* ‘to think’ gets the meaning of ‘to come to mind’ or ‘to occur to somebody’, *estimatu* ‘to esteem’ means ‘to give value to something’; the predicate *ulertu* ‘to understand’ has a transitional meaning of ‘to come to understand’; *ezagutu* ‘to know’ means ‘to meet’; *sinistu* ‘to believe’ conveys a transitional meaning of ‘to come to believe’; *gustatu* gets a transitional meaning where the object has undergone a transition to the set of things including ‘liked things’ for the subject; and finally, the predicate *gogoratu* ‘to remember’ conveys a meaning where the object has become a remembered thing. This meaning of *gogoratu* can be straightaway extracted from the etymology of the word (*gogo* ‘mind’ + *ra*<sub>ALL</sub>, see section 5.2). In the case of the perception verbs *ikusi* ‘to see’ and *entzun* ‘to hear’, we find the same situation. In the *-tu* headed variant of these predicates, they get an eventive inchoative meaning (see Smith 1997/1991 and Rothmayr 2009: 101-102).

- (76) a. Lehen Mikel kale-an ikusi dut  
 Before, Michael.ABS street-INE see-TU have.1sgERG.3sgABS  
 ‘Before, I saw Michel in the street’
- b. Zure deia entzu-n dut  
 your call.ABS hear-TU have.1sgERG.3sgABS  
 ‘I have heard your call’

In contrast, when all these predicates are put in an imperfective configuration with the *-tzen* suffix, they get a stative meaning, where no process or transition is involved.

- (77) a. Ondo joka-tu duzu-la pentsa-tze-n dut  
 well act-TU have.2sgERG-CMP think-TZE-INE have.1sgERG.3sgABS  
 ‘I think that you have acted properly’
- b. Arazoa ulertzen dut  
 problem.ABS understand-TZE-INE have.1sgERG.3sgABS  
 ‘I understand the problem’
- c. Jende asko ezagu-tze-n dut  
 people many.ABS know-TZE-INE have.1sgERG.3sgABS  
 ‘I know many people’
- d. Jonen istorioa sines-te-n dut  
 John-GEN story.ABS believe-TZE-INE have.1sgERG.3sgABS  
 ‘I believe John’s story’

- e. Jon-ek Ane asko estima-tze-n du  
 John-ERG Ane.ABS a.lot esteem-TZE-INE have.1sgERG.3sgABS  
 ‘John has Ane in a high esteem’
- f. Amets-i makarroiak gusta-tze-n zaizkio  
 Amets-DAT macaronis.ABS like-TZE-INE be.3plABS3sgDAT  
 ‘Amets likes macaroni’
- g. Zure istorioa gogora-tze-n dut  
 your story.ABS remember-TZE-INE have.1sgERG.3sgABS  
 ‘I remember your story’

This is also true for perception predicates:

- (78) a. Leiho-tik ikus-te-n zaitut  
 window-ABL see-TZE-INE have.1sgERG.2sgABS  
 ‘I see you from the window’
- b. Txarto entzu-te-n zaitut  
 wrong hear-TZE-INE have.1sgERG.2sgABS  
 ‘I am having problems to hear you’ lit. ‘I hear you wrong’

When headed by *-tzen*, these predicates have a different meaning from that of (75) and (76). With *-tzen*, the direct object does not undergo a change. In the case of *pentsatu* ‘to think’, it has the meaning of ‘to have an opinion about’. *Ulertu* ‘to understand’ conveys a metaphoric meaning of the direct object being in the understanding of the subject. *Ezagutu* ‘to know’ is used to convey a property of the subject, such that the subject knows many people. In *estimatu* ‘to esteem’, as stated clearly in the English translation, the subject has the object in esteem. In *gustatu* ‘to like’, the predicate describes a psychological state, where the direct object is within the set of ‘liked things’ for the subject. *Gogoratu* ‘to remember’ has a similar meaning, but with the object being within the set of ‘things in mind’ for the subject. As for perception predicates, their meaning in such examples can also be paraphrased as ‘the subject has the direct object is his/her sight or in his/her hearing’.

Basically, in all these cases, the direct object does not undergo a transition. The head WITHIN locates the object in an abstract landmark –the property expressed by Rheme–, and the subject is the holder or experiencer of the predication –predicated over the direct object.

The contrast between eventive and stative variants is due to the different ordering relations defined by AFTER and WITHIN. The Asp head AFTER orders the Ast-T *after* the Ev-T introduced by the predicate. This implicates that the right bound of the Ev-T is specified (and the Ev-T thus becomes [+bounded]), and that the result state denoted

by the predicates holds in the assertion time. WITHIN, in contrast, locates the internal argument within the set of things having the property expressed by the predicate.

- (79) a. Jon ezagu-tu dut *Present perfect*  
 John.ABS know-TU have.1sgERG.3sgABS  
 ‘I have met John’

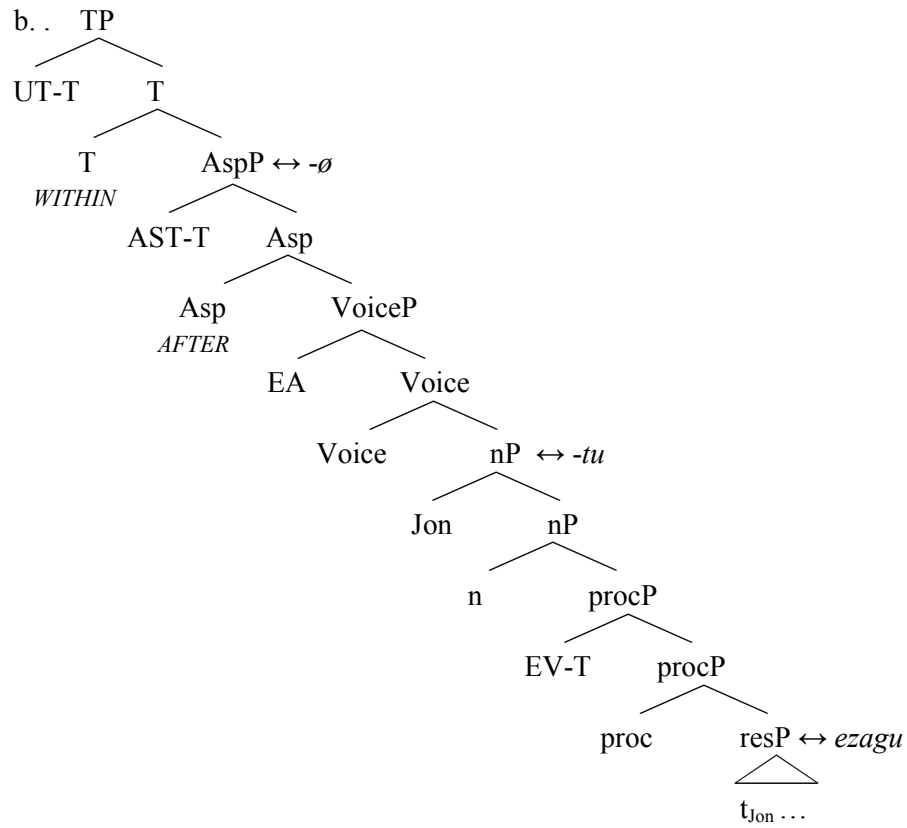



- (80) a. Jon ezagu-tze-n dut *Present imperfective with states*  
 John.ABS know-TZE-INE have.1sgERG.3sgABS  
 ‘I know John’

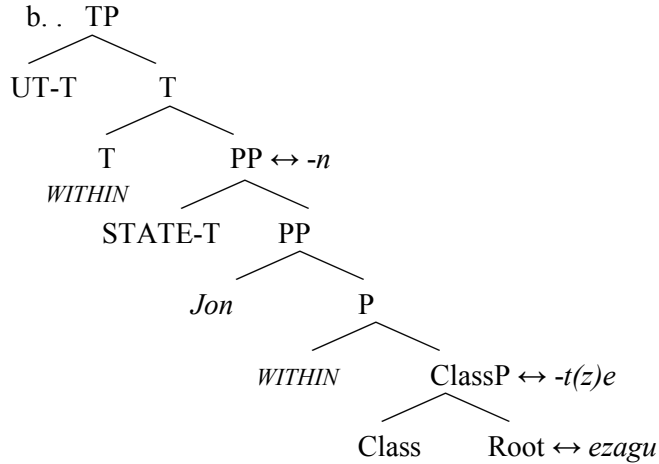

The tense of the clause does not change the aspectual interpretation of the predicates: perfective and imperfective forms –consisting of *-tu/-tzen* plus the auxiliary in the past tense– are also interpreted as eventive (transitional) or as stative, depending on the suffix.

- (81) a. [Lapurreta bat zela] pentsa-tu nuen hasiera-n *Past (transitional)*  
 [that it was a robbery] think-TU have.1sgERG.PST beginning-INE  
 ‘At the beginning, I thought it was a robbery’  
 ‘At the beginning, it occurred to me that it was a robbery’
- b. Jende asko ezagu-tu nuen  
 people many.ABS know-TU have.1sgERG.3sgABS.PST  
 ‘I met many people’
- (82) a. Ondo joka-tu zenuela pentsa-tze-n nuen *Past (stative)*  
 well act-TU have.2sgERG.PST-CMP think-TZE-INE have.1sgERG.3sgABS  
 ‘I thought / I used to think that you have acted properly’
- b. Jende asko ezagu-tze-n nuen  
 people many.ABS know-TZE-INE have.1sgERG.3sgABS  
 ‘I knew many people’

In the case of the perfective, T would be defined as AFTER instead of Asp. However, this brings exactly the same consequences, since the T AFTER head orders the Ut-T after the Ev-T, and thus, needs to specify the right bound of the Ev-T. T has access directly to the Ev-T, because Asp is not projected in the perfective (see section 8.5.3).

#### 8.4.4. On the universal perfect and the [ $\pm$ bound] distinction

The universal perfect interpretation is one of the types of perfect identified in Comrie (1976), together with the perfect of result, the experiential perfect and the perfect of recent past. In section 8.4.1, I have discussed the three latter perfects, which, as showed, involve the spelling out of *-tu-ø* or *-tu-a/-tu-ta/-tu-rik*. In all of them, I claimed that the Asp head can be defined as the spatiotemporal predicate AFTER (D&UE e.g. 2005), and that it gives rise, as a consequence, to a [+bound] predicate.

In this sense, the universal perfect can be considered to depart from the other types of perfect. The universal perfect (or persistent perfect in Comrie 1976) denotes a situation that started sometime in the past and still holds in the present, and, in this respect, the predicate embedded within it can be considered to be unbounded.

- (83) a. Ane has always lived in Bilbao  
b. Ane has always known the answer

There are two issues related to the universal perfect that I want to discuss in this section: firstly, the type of Asp head involved in this type of perfect, and, secondly, the types of predicates which combine with it.

Comrie (1976) points out that the universal perfect seems to be characteristic of English. Iatridou et al. (2001/2003) show that, in Bulgarian, the interpretation associated to the universal perfect can be obtained, but with a particular feature: the predicate must be built with the imperfective or the neutral stems.

Iatridou et al. (2001/2003) show that, both in Greek and Bulgarian, the combination of stative predicates with perfective morphology yields inchoative predicates. This is actually the same phenomena as that observed in section 8.4.3 for Basque. In Greek and in Bulgarian, a stative predicate like ‘to love’ in the perfect form can only have an inchoative reading (‘to start loving’ or ‘to fall in love’) and trigger an experiential interpretation (p.171-172):

- (84) O Γιάννη έχει αγαπήσει την Μαρία *Greek*  
The Jannis has-3sg loved the Mary  
‘John has started loving/fallen in love with Mary’  
(85) Marija (\*vinagi) e obiknala Ivan (\*ot 1980 nasam) *Bulgarian*  
Maria (\*always) is love-perf.part Ivan (\*from 1980 towards-now)  
‘Maria has fallen in love with Ivan’

Since the predicate has necessarily an inchoative interpretation, it is incompatible with durative adverbials like *always* or *since* adverbs (85). Nevertheless, unlike Greek,

Bulgarian does have a configuration where the perfect combines grammatically with these modifiers. Bulgarian has a perfect participle based on an imperfective stem. The imperfective stem, unlike the perfective, is unbounded. When it is combined with telic predicates, it does not assert the achievement of the goal. This way, Iatridou et al. (2001/2003) show that a perfect consisting of the imperfective stem is compatible with durative adverbials, and that it gives rise to the universal perfect interpretation.

- (86) Marija vinagi e običala Ivan *Bulgarian*  
 Maria always is love-imperf-part Ivan  
 ‘Maria has always loved Ivan’

Bulgarian has additionally another type of participle, which Iatridou et al. (2001/2003) call neutral. Like the imperfective, the neutral participle is also considered unbounded, and it is, therefore, compatible with durative adverbials.

- (87) Az šum pila vinoto ot sutrinta nasam *Bulgarian*  
 I am drink-neut.part the-wine from this-morning towards-now  
 ‘I have been drinking the wine since this morning’

The imperfective participle can be built on all classes of predicates, but the neutral participle can only be formed with accomplishments and activities. Both participles give rise to the universal perfect.

Let us consider Basque. The following examples show that Basque copulas can be put in the perfect and trigger a universal interpretation:

- (88) a. [Hamasei urte nituenetik] euki dut piercing-a sudurr-ean  
 [since I was sixteen] have.tu have.1sgERG.3sgABS piercing.ABS nose-INE  
 ‘I have had the piercing in my nose since I was sixteen’  
 b. Beti-danik iza-n gara lagunak  
 always-since be-TU be.1plABS friends  
 ‘We have always been friends’

Regarding non-copular stative predicates, there seems to be more variation, but generally, an universal reading is permitted.

- (89) a. ?[Zortzi urte nituenetik] ezagu-tu (iza-n) dut denda hau  
 [Since I was eight] know-TU (be-TU) have.1sgERG.3sgABS shop this.ABS  
 hemen  
 here  
 ‘I have known this shop here since I was eight’  
 b. Jonek [zortzi urte zituenetik] sinis-tu (iza-n) du Jainkoa-rengan  
 John-ERG [since he was eight] believe-TU (be-TU) have.3sgABS God-INE  
 ‘John has believed in God since he was eight’

- c. [Txiki-txikitatik] gustatu (izan) zait futbolean joka-tze-a  
 [since I was a kid] like-TU (be-TU) be.3sgABS.1sgDAT football-INE play-TZE-DET  
 ‘I have liked playing football since I was a kid’
- d. [Betidanik] bizi iza-n naiz Bilbon  
 [since always] live be-TU be.3sgABS Bilbo-INE  
 ‘I have always lived in Bilbao’

The same pattern is observed with eventive predicates like activities. Note that in all of them, the use of the copula *izan* ‘be’ is optional.

- (90) a. [Betidanik] hitz egi-n (iza-n) dugu euskara-z  
 [since always] word do-TU (be-tu) have.1plERG Basque-INSTR  
 ‘We always have spoken in Basque’
- b. [Txiki-txikitatik] joka-tu (iza-n) dut futbole-an  
 [since I was a kid] play-TU (be-TU) have.1sgERG football-INE  
 ‘I have played football since I was a kid’

With achievements, in contrast, the use of the copula *izan* ‘be’ is obligatory in order to obtain a universal reading.

- (91) a. Beti etorr-i \*(izan) naiz 23:00-etan etxe-ra  
 always come-TU (be-TU) be.1sgABS 23:00-INE etxe-ALL  
 ‘I have always come home at 23:00’
- b. Beti apurtu \*(izan) ditut eskutitzak [irakurri ondoren]  
 always break-TU (be-TU) have.1sgERG.3plABS letters.ABS [after reading]  
 ‘I have always broken the letters after reading them’

Note that the universal reading is only obtained when the perfect is modified by durative adverbials like *since...*, *always* etc. This is an aspect that has been noted by Iatridou et al (2001/2003). If these adverbs are not used, the interpretation is experiential, of result or of recent past.

As mentioned in section 8.2.2.3, Iatridou et al. (2003: 175) (see also Pancheva 2003) consider that “the perfect contributes a time span in/throughout which there is a (un)bounded eventuality”. The universal perfect, specifically, requires that the predicate holds throughout the perfect time span. Thus, it needs that the predicate is unbounded. Unbounded predicates are those where the end-point is not reached. In English the universal perfect can be obtained with statives or progressives, and in Bulgarian, with the imperfective and neutral stems. In Basque, it can be obtained with the *-tu* morpheme in most of the cases, and with both the *-tu* and the copula *izan* in the case of achievements. Note that in the universal interpretation of eventive verbs (90)-(91), the predicates are interpreted as habitual (frequentative). I think that this is necessary to be unbounded and to trigger an universal reading.



(94) a. universal *-tu* + present tense (89a)

b. *-tzen* + present tense (89b)

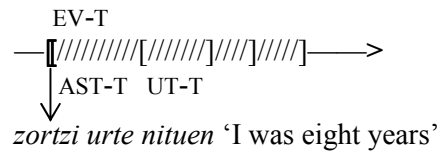
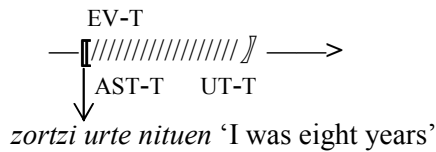

Nevertheless, both sentences share one property: in both of them, the left boundary of the Ast-T coincide with the left boundary of the Ev-T, and this point is specified by the argument of the durative adverbial. How all these aspectual features are constructed in syntax is an issue that needs to be studied further. In any case, what is clear is that *-tu* in the universal perfect is not spelling out an AFTER predicate.

#### 8.4.5. Excursus on the nature of *-tu*

In chapter 3, 4 and 5, I have explored the eventive decomposition of predicates where *-tu* lexicalizes *proc* (e.g. *handi-tu* (big-TU) ‘to increase’) or occurs with another LI lexicalizing *proc* (e.g. *etxe-ra-tu* (home-ALL-TU) ‘to go/take sb home’). Thus, in all those contexts, *-tu* was related to the projection of the process subevent and its lexicalization. However, in section 8.4.1 and 8.4.4 of this chapter, I have shown that *-tu* can also be lexically inserted in configurations where *proc* is not present, e.g. in the perfect or perfective forms of copular predicates.

In non-finite contexts, the lexicalization of *-tu* does not correlate either with the presence of *proc*. For instance, in complement position of the modal predicate *behar* ‘must’, some eventive/stative polysemic predicates –those analyzed in section 8.4.3– headed by *-tu* (e.g. *ezagutu* ‘to know’, *pentsatu* ‘to think’, *estimatu* ‘to esteem’) can retain their stative meaning when the modal has epistemic interpretation (Haddican & Tsoulas 2012: 440).

- (95) a. Nere kardiologoa-k oso ongi ezagu-tu behar du bihotza-ren  
 my cardiologist-ERG very well know-TU must have.3sgERG heart-GEN  
 anatomia  
 anatomy.ABS  
 ‘My cardiologist has to know the anatomy of the heart very well’
- b. [Hau egin eta gero], tontoa naiz-ela pentsa-tu behar duzu  
 [after doing this] stupid be.1sgABS-CMP think-TU must have.2sgERG  
 ‘After doing this, you must think I am stupid’
- c. Miren-ek asko estimatu behar zaitu  
 Mary-ERG a.lot esteem-TU must have.3sgERG.2sgABS

[horrelako opari bat egin badizu]  
 [if she has given you this gift]  
 ‘Miren must esteem you a lot if she has given you this present’

The predicates *ezagutu* ‘to know’ (95a), *pentsatu* ‘to think’ (95b) and *estimatu* ‘to esteem’ (95c) are stative in these examples. As a matter of fact, the epistemic interpretation of the modal *must* is used as a test for stativity (Katz 1995): the epistemic interpretation arises when the complement of *must* is a stative predicate (see section 8.2.2.3). Copular predicates headed by *-n* (a non-productive variant of *-tu*) can also occur in the complement position of the epistemic modal:

- (96) Aingeru-k etxe-an egon behar du dagoeneko  
 Aingeru-ERG home-INE be-TU must have.3sgERG by.now  
 ‘Aingeru must be at home by now’

These pieces of evidence suggest that *-tu* cannot always be related to the projection of *proc*. In the cases just shown, *-tu* is not spelling a *procP* node, and *proc* is not even present in the structure. Thus, we must conclude that although a *procP* node may be specified in the lexical entry of *-tu*, this feature is not always “used” when *-tu* is inserted in the lexicalization, and that those cases are not subject to the Constraints on Underassociation (Ramchand 2008b) discussed in section 3.2.2. Perhaps, we must posit that there are two lexical entries: *-tu*<sub>1</sub> and *-tu*<sub>2</sub>, where the stored tree of *-tu*<sub>2</sub> does not contain the *procP* node.

Since neither *proc* nor the AFTER Asp head seem to be the core projections lexicalized by *-tu* (see section 8.4.4), and since *-tu* headed predicates seem to fit a nominal category, we are led to the conclusion that *-tu* may be lexically specified to spell out a nominalizer nP node. However, the view on categorization adopted in this dissertation would not be compatible with positing a nominalizer like *n* to be present in syntax. In a speculative way, I will suggest that *-tu* may be lexicalizing a head which introduces a left boundary (*/P*).<sup>132</sup> The projection of */P* would indicate that the element it selects for has an initial point specified. For instance, the states which can be headed by *-tu* in the complement of the modal *must* (e.g. *ezagutu* ‘to know’, *estimatu* ‘to esteem’, *gustatu* ‘to like’) denote states which must have started sometime, i.e. after the transition to that state (interestingly, the transitional variant is lexicalized by the same LI, see section 8.4.3).

<sup>132</sup> I am grateful to Antonio Fábregas for coming up with the idea of positing this node.

Going back to the universal perfect analyzed in section 8.4.4, recall that in the universal perfect, which is obtained in Basque with *-tu* headed predicates, I claimed that the left bound of the event/state is specified by temporal adverbials like *since*, and that the right bound is provided by tense. Perhaps in this context, the projection of *l* is providing the right context for the adverbial to specify the left bound.

Regarding how this projection can contribute to nominals, imagine that before dividing stuff and make it countable (a function attributed to the Classifier projection in Borer 2005a, and also adopted in this dissertation as the projection lexicalized by *-tze*), it is necessary to establish the boundaries of the stuff, so that it can be, then, interpreted as atomic or as non-atomic. Perhaps, the first function that must be applied is a function of individuation of a left boundary, i.e. to state where the stuff starts. Then, another function providing the right boundary will be necessary, so that the stuff can turn into countable units of stuff.

Within this hypothetical analysis, *-tu* would be lexicalizing a node which is lower in the hierarchy than ClassP:

(97) Speculative hierarchy related to nominals

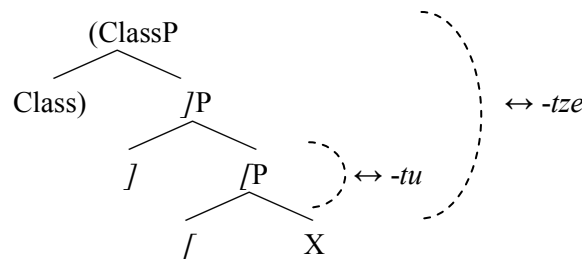

The fact that *-tze* spells out more nodes than *-tu* would also explain why some LIs can lexicalize the whole *JP+procP+resP* but need to be combined with *-tze* in the imperfective context. For instance, *-tu*-less eventive predicates (e.g. *bete* ‘to fill’, *hil* ‘to die or to kill’, *gorde* ‘to hide’ etc.) do not need *-tu* in complement position of the modal *behar* ‘must’ or in the perfect configuration (see section 3.2.3), but need *-tze* when they are in the imperfective analytic configuration.

- (98) a. Edalontzia bete dut  
 glass.ABS fill.TU have.1sgERG.3sgABS  
 ‘I have filled the glass’
- b. Edalontzia bete nahi dut  
 glass.ABS fill.TU wish have.1sgERG.3sgABS  
 ‘I want to fill the glass’



- (99) Edalontzia bete-tze-n dut  
glass.ABS fill-TZE-INE have.1sgERG.3sgABS  
'I fill the glass'

These data can be accounted for by considering that *bete* lexicalizes up to  $/P$ , and that when there is more structure projected –until ClassP–, *-tze* has to be inserted. If both *-tu* and *-tze* were considered LIs lexicalizing similar syntactic heads (e.g. nP), we would not be able to explain why *bete* does not need *-tu* but needs *-tze*.

## 8.5. NON-ACTIVE Asp

In this section, I will deal with configurations where Asp is non-active. Following Laka (1993b), Arregi (2000) and Arregi & Nevins (2012), I propose that in the synthetic configuration, Asp is not projected and as a consequence, the predicates which are lexically specified to be inserted in the high functional domain, get lexicalized in the local environment of T. In the following lines, I will explain how the aspectual interpretation is obtained in those contexts, assuming the proposal made in Demirdache & Uribe-Etxebarria (2014). Additionally, I will show that the lack of Asp does not always result in a synthetic configuration. As a matter of fact, several predicates in Basque occur in an aspect-less structure, but surface in the analytic way. I will suggest that this scenario takes place because the LIs lexicalizing those predicates lack the lexical specification to be inserted high. Finally, I will consider briefly the perfective category in Basque, which, does not consists of the Asp head AFTER (D&UE 2005 2014) but which gets lexicalized in a *-tu* analytic configuration.

### 8.5.1. The synthetic configuration

The synthetic configuration is nowadays restricted to very few verbs (Euskaltzaindia 1997 [1987]), but some of them are of a high frequency in the language, such as the following: *egon* (the stage level) ‘to be’, *joan* ‘to go’, *etorri* ‘to come’, *ibili* ‘to walk, be engaged in’, *jakin* ‘to know’, *eduki* ‘to have’, *ekarri* ‘to bring (here)’, *eraman* ‘to take, carry, wear, as well as a kind of stage level be’, *jardun* ‘to be engaged in’ or ‘to talk’ etc. The list bellow shows the predicates which have nowadays an available synthetic form (taken *Sareko Euskal Gramatika*, Salaburu et al. 2008-2010).

#### (100) PREDICATES WITH AN AVAILABLE SYNTHETIC FORM

|                                    |                                         |
|------------------------------------|-----------------------------------------|
| atxeki ‘to hold’                   | egin ‘to do’                            |
| eduki ‘to have’                    | ekarri ‘to bring’                       |
| egon (the stage-level) ‘to be’     | ekin ‘to undertake, to set’             |
| entzun ‘to hear’                   | erabili ‘to use’                        |
| erion ‘to flow’                    | eraman ‘to take, carry’                 |
| etzan ‘to lie’                     | eroan ‘to take, to carry’               |
| etsi ‘to hold’                     | erran ‘to say’                          |
| ezagutu ‘to know’                  | etorri ‘to come’                        |
| ikusi ‘to see’                     | ibili ‘to walk, to be engaged in’       |
| iraun ‘to last’                    | iharduki ‘to quarrel, to be engaged in’ |
| iritzi ‘to think of, to be called’ | io ‘to say’                             |

|                 |                                    |
|-----------------|------------------------------------|
| irudi 'to seem' | jardun 'to talk, to be engaged in' |
| jakin 'to know' | jarraiki 'to continue'             |
| joan 'to go'    |                                    |

Some of these predicates are hardly found in the synthetic configuration in contemporary Basque (e.g. *entzun* 'to hear', *ezagutu* 'to know', *erran* 'to say') and others are only used in certain person combinations and with certain meanings (e.g. *etzan* 'to lie', *atxeki* 'to hold').

Note that this list represents the citation form of the predicates, headed by *-tu*, and it is, therefore, homophonous with the infinitive and the participle. The roots appearing in the synthetic form corresponding to the predicates mentioned in the text are broadly: *go* (the stage level) 'be', *oa* 'go', *tor/to* 'come', *bil* 'walk, be engaged in', *ki* 'know', *uka* 'have', *kar* 'bring', *rama* 'take, carry, wear', and *ihardu* 'be engaged in, talk'.

- (101) a. da-ki-gu  
 PRT-know-3plERG  
 'we know'  
 b. na-rama-zu  
 1sgABS-wear-2sgERG  
 'you carry/wear me' or 'you are carrying/wearing me'

The perfect participle (as well as the infinitive and the citation form) involves the roots listed, plus the prefix *\*e-* and the suffix *-i* or *-n* (non-productive variants of the *-tu* suffix). The imperfect participle of these predicates, on the other hand, consist of the prefix *\*e*, the root and the *-tzen* suffix.

- (102) a. jaki-n dugu  
 know-TU have.1plERG  
 'we have known' (like 'get aware of something')  
 b. erama-n nauzu  
 carry-TU have.2sgERG.1sgABS  
 'you have carried/taken me (somewhere)'
- (103) a. jaki-te-n dugu  
 know-TZE-INE have.1plERG  
 'we usually know' (habitual)  
 b. erama-te-n nauzu  
 carry-TZE-INE have.2sgERG.1sgABS  
 'you bring me' (habitual)

It is interesting to note that only a small set of predicates, as the ones above, can be used in the synthetic form, but, in contrast, all the predicates which can be used in the synthetic form can also appear in the analytic (102)-(103). In section 8.6, I will show

that the occurrence of these predicates in the analytic and in the synthetic configuration influences the viewpoint and, sometimes, the situational aspectual interpretation.

Following the analysis put forward in the preceding sections, I consider that the predicates appearing in the synthetic form are actually the only verbal elements in the language. When these predicates are realized in the synthetic configuration, the LIs have been lexically inserted in T's local environment. The predicates occurring in the analytic configuration on the contrary –which involve those never appearing in the synthetic form, as well as the \**e-root-i/-n/-tzen* combination of predicates having a synthetic form– surface as nominals, as suggested in the previous section.

#### 8.5.1.1. VIEWPOINT ASPECT IN THE SYNTHETIC CONFIGURATION

The viewpoint aspectual interpretation of the synthetic configuration seems to be quite restricted. Euskaltzaindia (1997[1987]) and Laka (1993b) consider that the synthetic configuration has a *punctual* value, in the sense that it denotes that the event time holds at the assertion time.<sup>133</sup> Depending on the predicate and on the context, it can get a progressive like meaning, such as in some uses of the predicate *etorri* ‘come’ (104a) and *eraman* ‘to bring’ (104b), or a nonprogressive/continuous interpretation, like with the stative predicate *jakin* ‘to know’ (105) or the predicates *etorri* ‘to have origin’ and *eraman* (stage level) ‘to be’ in other contexts (106) (see Albizu 2001, Alcazar 2002). These aspectual interpretations have been termed respectively *jarraikorra* ‘continuous’ and *mugagabea* ‘unbounded’ in Euskaltzaindia (1987).

- (104) a. Jone      autobus-ean dator  
           Jone.ABS bus-INE      comes  
           ‘Jone is coming in the bus’  
           b. Gaur jertse gorria daramat      *Progressive*  
           Today jumper red.ABS wear  
           ‘Today, I am wearing the red jumper’
- (105) Jonek      erantzuna daki      *Nonprogressive/continuous*  
           John-ERG answer      knows  
           ‘John knows the answer’
- (106) a. Hitz hori      latin-etik dator      *Nonprogressive/continuous*  
           word that.ABS latin-ABL comes  
           ‘That word comes from Latin’ (it has Latin origin).

<sup>133</sup> This punctual value must not be mistaken with the semelfactive punctual value.

- b. Bi urte daramatza Londres-en  
 two year wears London-INE  
 ‘I have been in London for two years’

Regarding the habitual interpretation, there is more controversy about whether the synthetic configuration can give rise to such a reading. Some speakers do not accept sentences like (107a), where the inflected verb *noa* ‘I go’ is used in a habitual context (see, for instance, Arregi 2000). Instead, those speakers prefer to use an analytic form of the predicate, like in (107b).

- (107) a. (#) Astelehen-etan noa Gasteiz-era  
 Monday-INE go Gasteiz-ALL  
 ‘I go to Gasteiz on Monday’  
 b. Astelehen-etan joa-te-n naiz Gasteiz-era  
 Monday-INE go-TZE-INE be.1sgABS Gasteiz-ALL  
 ‘I go to Gasteiz on Monday’

Nevertheless, apart from these examples, the synthetic form seems to be actually used widely in order to express habitual events, as pointed out by Albizu (2001), Alcazar (2002) and Garzia (2005) and, thus, that use must not be underestimated:

- (108) Egunero **dakarte** zerbait  
 Every.day bring something  
 ‘They bring something everyday’  
 (109) Ruperrek, goizeko 7-etan tabernara **doanean**, [kafesnea eskatzen du]  
 Ruper-ERG, morning-GEN 7-INE bar-ALL goes-INE, [he asks for coffee]  
 ‘When Ruper goes to the bar at 7 in the morning, he asks for coffee’  
 (110) Askotan esplotazio horrek, ondoren, gazte marjinazioa **zekarren**...  
 many.times exploitation that-ERG, later, youth margination.ABS brought  
 ‘Many times, that exploitation brought youth margination...’

Although in all these cases, *-tzen* analytic forms can also be used (and sometimes preferred by some speakers), the synthetic counterparts are also accepted, and its use is actually found in written corpora.

In all these cases, the sentence denotes that the event or situation conveyed by the predicate holds at the time of the assertion, as an atomic dynamic event, as a non-atomic sequence of events or as a state. Leaving apart the cases where the LIs associated to the predicates lexicalize the Asp head itself (as in *ibili* ‘be engaged in’, *jardun* ‘be engaged in’, etc.), I claim that the imperfective aspectual interpretation is obtained as a default,<sup>134</sup> precisely because Asp is not projected. Following D&UE (2014), I suggest that in this case, specifically in the case of eventive predicates, the

<sup>134</sup> I am grateful to Myriam Uribe-Etxebarria for suggesting this option to me.

interpretation of Asp is resolved resorting to binding, which gives rise to an imperfective reading.

As explained in section 8.2.2.2, D&UE (2014) consider that when Asp is empty, the relation between the Ast-T and the Ev-T can be resolved in two anaphoric ways. Just like individual denoting nouns phrases, D&UE (2014) suggest that the reference of time denoting DPs (namely, Ast-T and Ev-T) can be obtained by either (i) coreference or (ii) variable binding (Reinhart 1997, Heim & Kratzer 1998 a.o.). If it is resolved by coreference, the resulting interpretation is perfective. If, in contrast, it is resolved by means of binding, the interpretation obtained is imperfective.

Binding is a relation between operators and variables implemented by  $\lambda$ -abstraction.

(111) Ane dator  
 Ane.ABS comes  
 ‘Ane is coming’

(112) Ast-T  $\lambda_{Ev-T}$ [Ane dator (Ev-T)]

The Ev-T is a free variable, which in this case, is bound by a  $\lambda$ -operator adjoined between Ev-T and Ast-T. The Ev-T variable has to satisfy the property of being a time where ‘Ane comes’ is true. Temporal binding ensures that the time span denoted by Ast-T has to be also a time where the property ‘Ane comes’ holds (p.12). Therefore, according to D&UE, binding merely requires that the Ast-T and the Ev-T temporally overlap at some point. Obeying this requirement, several temporal configurations can emerge.

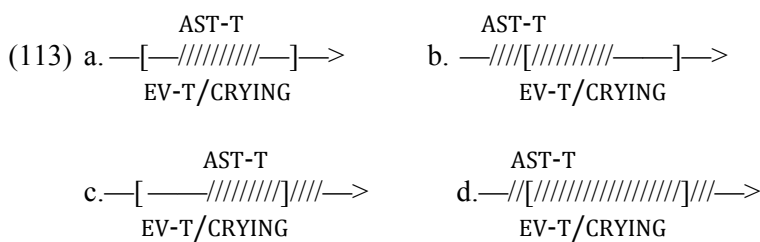

[D&UE to appear: 12]

The binding mechanism by which the value of the viewpoint aspect is obtained can account for the on-going and habitual interpretation of the synthetic configuration, since in both of them, there is an overlap between the Ev-T and the Ast-T. Thus, the aspectual interpretation obtained in the synthetic form is triggered by the default strategy of interpreting an empty Asp head, which, according to D&UE (2014) is

binding. Regarding the non-habitual and non-progressive interpretation of stative predicates, see section 8.5.2.

#### 8.5.1.2. LEXICALIZATION AND MORPHOLOGICAL CONSEQUENCES

The fact that Asp is not projected has two consequences: (i) that Asp does not make an explicit syntactic/semantic contribution, but instead, its value is resolved by means of binding; and (ii) it does not block the insertion of the LI lexicalizing the predicate in the high functional domain. It seems that when Asp is contentful and projected, it needs to be lexicalized together with the predicate. This may be just a stipulation, or it may follow from the fact that Asp manipulates the Ev-T introduced by the process subevent.

I suggest that the LIs used in synthetic forms are able to lexicalize a head which is above the first phase, e.g. Asp, Mood, Perception or Andative (Cardinaletti & Shlonsky 2004, Cinque 2006). In this way, it provides the necessary support for other tense and inflectional morphemes. This may be, for example, the lexical entry of the root *oa* of the predicate *joan* ‘to go’, where X corresponds to a head belonging to the high functional domain.

(114) *oa* ↔ </oa/, X, conceptual content>

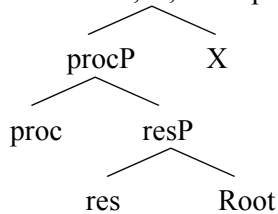

When the LI *oa* is inserted in X, the whole predicate is lexicalized with it.

#### 8.5.2. Bare analytic predicates

Now I will present another kind of configuration where the Asp head is not projected but the predicate is aligned in an analytic way. Throughout the dissertation, I have called these predicates bare analytic predicates. These predicates consist of elements which are independently used in the language as nouns, adjectives or inessive PPs. As already commented several times, these predicates are not headed by morphemes *-tu* or *-tzen*. This is a small sample (see section 3.3 for a more exhaustive list).

(115) *Axola izan* ‘to matter’, *atsegin izan* ‘to like’, *maite izan* ‘to love’, *gorroto izan* ‘to hate’, *ezagun izan* ‘to be evident, to know’, *gustoko izan* ‘to like’, *falta-n izan* ‘to lack’, *gogoan izan* ‘to remember’ etc.

- (116) a. *Justizia eta zuzenbidea maite ditu*  
 justice and law.ABS love have.3sgERG.3plABS  
 ‘He/she loves justice and law’  
 [Elizen arteko biblia 2004: Sal 33,5]
- b. *Gorroto dut gerra* [B.Atxaga 2003: 81]  
 hatred have.3sgERG.3sgABS war.ABS  
 ‘I hate the war’

Even though they have an analytic configuration and they lack *-tzen*, they trigger an imperfect aspectual interpretation, similar to the English simple present. I argue that the imperfect aspectual interpretation is due to the fact that Asp is not projected in these configurations.

#### 8.5.2.1. VIEWPOINT AND SITUATIONAL ASPECT IN BARE ANALYTIC PREDICATES

As I have already mentioned, these predicates do not take the *-tu* or the *-tzen* suffix. Nevertheless, their viewpoint aspectual value is clearly imperfective. As a matter of fact, their interpretation is very similar to that of the synthetic configuration: in these sentences, the situation denoted by the predicate holds at the Ast-T.

- (117) *Hemen-go beste lagun batzuk ditu gogo-an*  
 here-GEN other friend some.ABS have.3sgERG.3plABS mind-INE  
 ‘He/she has other friends from here in mind’  
 [E. Jimenez, 2003: 42]
- (118) *Nik nahi-ago dut horrela ibili* [M.Oxandabaratx 2006: 76]  
 I-ERG wish-COMP have.1sgERG this.way be-TU  
 ‘I prefer to be this way’
- (119) *idea Maritxu-ri zor diot* [K. Izagirre 1999: 107]  
 idea.ABS Maritxu-DAT debt have.1sgERG.3sgDAT  
 ‘I owe this idea to Maritxu’

The syntactic structure underlying bare analytic predicates and the synthetic configuration is similar. The Asp head is empty and it is not projected. However, note that the inner aspectual interpretation of bare analytic predicates is different from the predicates appearing in the synthetic form: generally all predicates appearing as bare



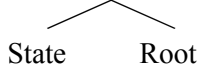

not lexically specified to do so. The LI *maite* ‘love’, associated to the predicate *maite izan* ‘to love’ lexicalizes just a stateP, as illustrated:

- (122) *maite* ↔ </maite/, stateP, conceptual content>  

As a consequence, *maite* will only spell out the first phase domain, and will not be inserted in the high functional domain. Since it is lexicalized downstairs, it will surface with nominal category. In relation to this, recall that there are some bare predicates consisting on inessive phrases, e.g. *gogoan izan* ‘to remember’. In this case, the state subevent and its Rheme complement are lexicalized separately, the inessive being the exponent of the state<sup>136</sup> and *gogo* ‘mind’ the exponent of the Rheme. Since these two elements are lexicalized separately, instead of surfacing with nominal category, they are realized as an adposition and a noun respectively (see section 5.4.2).

All in all, it seems that the difference between a synthetic configuration and the analytic configuration of a predicate like *maite izan* ‘to love’ lies on the lexical specification of the LIs associated with the predicates. The LI of a predicate appearing in the synthetic configuration, such as *oa* in *joan* ‘to go’, is specified with a X node, where X is understood as a functional head located above the first phase, whereas *maite* ‘love’ is specified only with a stateP node.

### 8.5.3. Some considerations of the perfective

The perfective represents another context where Asp is claimed to be empty (D&UE 2004 2005 2014). Basing on this consideration, I claim that the perfective in Basque proves again that the LI *-tu* is not the exponent of an aspectual AFTER head.

The perfective category in Basque is analytic, also in the case of predicates which can have a synthetic form, like *joan* ‘to go’ (123a). It consists of the *-tu* predicate and of the auxiliary in the past tense.

- (123) a. Ane        etxera        joa-n    zen  
           Ane.ABS home-ALL go-TU be.3sgABS.PST  
           ‘Ane went home’

<sup>136</sup> Recall that Path/Place adpositions are topologically and structurally parallel to the subeventive structure (see section 5.2), so that an inessive or an allative adposition can also lexicalize a subevent. This is the case of the inessive phrase in *gogoan izan*, which lexicalizes a stateP.

- b. Irati-k fandangoa dantza-tu zuen  
 Irati-ERG fandango.ABS dance-TU have.3sgERG.3sgABS.PST  
 ‘Irati danced the fandango’

D&UE (2014) argue that in the perfective, Asp is empty and that the relation between the Ast-T and the Ev-T is resolved by means of covaluation/correferrence. This operation implies that the initial and final bounds of both the Ast-T and the Ev-T are assigned the same reference value from the discourse storage, the same point in time. In this way, in the perfective, the predicate is seen as a whole, with its initial and final bounds.

- (124) Amets came

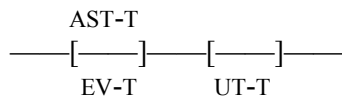

On the other hand, T is defined as AFTER, and orders the Ut-T to the right of the right boundary of the Ast-T/Ev-T. This yields past tense.

Let us consider the Basque perfective. If the *-tu* morpheme were the exponent of an aspectual head AFTER (+bound), it would locate the Ast-T to the right of the Ev-T. Similarly, since the tense is past, T would locate the Ut-T *after* the Ast-T. According to D&UE (e.g. 2005), this would be exactly the configuration of the past perfect (pluperfect).

- (125) EV-T AST-T UT-T  
 — [ — ] — [ — ] — [ — ] —

Since the sentences in (123) do not have a pluperfect interpretation but a perfective one, (125) cannot correspond to their aspectual/temporal configuration, and *-tu* must not be the exponent of the AFTER Asp head.

We can think, then, that *-tu* in the perfective is just spelling out the left boundary of the predicate, as suggested in section 8.4.5, and that when it is selected by the AFTER T head, the Ut-T gets ordered after the whole Ev-T. This hypothesis, however, would raise another question: if Asp is not projected in the perfective, why does the predicate surface in the analytic form? Asp is not projected in this context, and thus, it cannot force the lexicalization of the predicate in its complement position.

At this moment, I cannot find an answer for this question. The answer may be related to the fact that, apart from the predicates which can appear in the synthetic form, the LIs associated to the rest of the predicates in Basque are only specified to lexicalize the first phase, and need to be combined with *-tu/-tze* in order to be

externalized. *-Tu* and *-tze* have nominal category, and as such, cannot be lexicalized in high functional domain.

This explanation, however, runs immediately into problems. Before I have claimed that because of being lexicalized in Asp's area, the predicate surfaces with nominal category (as *-tu* or *-tze*). If, now, I argue that the predicate is not lexicalized in T because it is nominal, then, the argument becomes circular. Furthermore, the predicates which have a X specification in their LI –*oa* of *joan* 'to go' etc.– can be lexicalized high, and under this premise, they would need to be able to trigger a perfective interpretation, which is contrary to fact. In this sense, it is interesting to note that the synthetic configuration used to have a perfective interpretation at earlier stages of the language, as it is observed in texts of the 15<sup>th</sup> and 16<sup>th</sup> century (Lafon 1943, Mounole 2011) but, nowadays it has lost that ability.

## 8.6. SOME HISTORICAL NOTES AND THE FUNCTION OF Asp

Before reaching the end of this chapter, let me present some very interesting historical notes. In a diachronic study of the Basque verbal complex, Mounole (2011: 342) claims that, in the period covering the 15<sup>th</sup>, 16<sup>th</sup> and 18<sup>th</sup> centuries, the number of predicates inflected in the synthetic form is reduced to a half, in favor of the analytic configuration. According to her, those which maintain the synthetic form are the most frequent ones and, interestingly, she points out that most of them are stative.

En deux siècles, le nombre de verbes synthétiques a considérablement diminué. [...] En même temps, les paradigmes synthétiques restants (présent, passé inaccompli, impératif), voient le nombre de verbes s'amoinrir. Seuls les verbes les plus fréquemment usités dans la langue conservent leur forme synthétique, la majorité d'entre eux étant des verbes statifs (Mounole 2011 : 342).

In addition, she also claims (p.300-303, 342) that the *-tzen* analytic form (*-tzen + izan/\*edun*) was initially incompatible with stative predicates.

Nous l'avons vu, la périphrase [participe présent + *izan* «être» / *\*edun* «avoir» de présent] s'est étendue aux verbes dynamiques ou non-statifs, tandis que les verbes statifs résistent à cette évolution, en conservant leur forme synthétique de présent. On peut tout à fait imaginer que la première fonction de cette périphrase, elle-même issue d'une expression locative, était celle de progressif, et que par conséquent, elle n'était combinable qu'avec les verbes dynamiques (Mounole 2011: 302-303)

These two aspects of the evolution of Basque verbal forms are remarkable. On the one hand, they suggest that stative predicates retain better their synthetic form, in contrast to eventive predicates. On the other hand, they suggest that when Basque predicates started to abandon their synthetic form and started to surface in the analytic aspectually inflected imperfective form, eventive predicates were the first ones undergoing that transition. It seems that the analytic aspectually inflected form was, at least in those earlier stages, closely related to eventivity.

That stative predicates retained better their synthetic form can be explained within the approach taken in this chapter. States denote properties of times, and as such, they can be directly combined with tense, which also denotes a property of times. It is natural, then, that states occur more easily in configurations without Asp. As mentioned before, Katz (2003) suggests that aspectual operators have the function of

turning a property of events into a property of times. Thus, since states already denote a property of times, they do not need to be combined with Asp in order to be compatible with tense.

In this sense, it is remarkable that, if a stative predicate can be aligned in the synthetic form, the stative meaning will be generally restricted to the synthetic alignment of the predicate, and will not be obtained in the analytic *-tzen*. Therefore, the stative predicates which have a robust synthetic use are aligned in the synthetic way in order to convey that meaning, and if they are put in the analytic, the continuous interpretation is lost (see also Alcazar 2002).

- (126) a. Jon-ek erantzuna daki *non-progressive, non-habitual*  
 John-ERG answer.ABS knows  
 ‘John knows the answer’  
 b. Jon-ek erantzuna jaki-te-n du *Habitual*  
 John-ERG answer.ABS know-TZE-INE have.3sgERG.3sgABS  
 [galdetzen dioten bakoitzean]  
 [every time they ask him]  
 ‘John knows the answer every time they ask him’
- (127) a. Jakitea oroimen-ean datza *non-prog., non-habitual*  
 knowledge.ABS memory-INE lies  
 ‘Knowledge lies in memory’  
 b. \*Jakitea oroimen-ean etza-te-n da  
 knowledge.ABS memory-INE lie-TZE-INE be.3sgABS  
 Intended: ‘Knowledge lies in memory’  
 c. Jon sofa-n etzaten da [nekatuta datorrenean] *Habitual*  
 John.ABS sofa-INE lie-TZE-INE be.3sgABS [when he comes tired]  
 ‘John lies in the sofa when he comes tired’
- (128) a. Ane-k bost arkatz dauzka *non-progressive, non-habitual*  
 Ane-ERG five pencil.ABS has  
 ‘Ane has five pencils’  
 b. Anek bost arkatz eduki-tze-n ditu *Habitual*  
 Ane-ERG five pencil.ABS have-TZE-INE have.3sgERG.3plABS  
 ‘Ane usually has five pencils’

The predicate *etzan* ‘lie’, which is a predicate of position in the synthetic form (127a), becomes a predicate to assuming a position when aligned in the analytic configuration (127c). This may be connected with the diachronic tendency mentioned above (Mounole 2011) that stative predicates retain better its synthetic form. As a matter of fact, many predicates appearing in the synthetic form which have

stative/eventive meaning alternations generally maintain their stative meaning only in the synthetic configuration.<sup>137</sup>

- (129) a. Basamortu-an zehar doa bidea [Askoren artean, 2004: Eg 8,26]  
 desert-INE through goes way.ABS  
 ‘The way goes through the desert’  
 b. Bidexka bat doa etxe aurre-ko atariraino  
 path one.ABS goes house front-GEN entry-TERM  
 ‘A path goes up to the entry of the house’ [O. Arana (J.M. Coetzee), 2004: 215]
- (130) a. # Basamortu-an zehar joa-te-n da bidea  
 desert-INE through go-TZE-INE be.3sgABS way.ABS  
 Intended: ‘a way goes through the desert’  
 b. # Bidexka bat joaten da etxe aurre-ko atariraino  
 path one.ABS go-TZE-INE be.3sgABS house front-GEN entry-TERM  
 Intended: ‘A path goes up to the entry of the house’

A similar eventive/stative variation is found in the synthetic form of the predicates *etorri* ‘come, have origin’ and *eraman* ‘bring, wear, (stage level) be’, as illustrated in Albizu (2001). A common property that all these varying predicates share is that their stative possible interpretation is lost in their analytic configuration.

- (131) a. Hitz hau latin-etik dator  
 word this.ABS latin-ABL comes  
 ‘This word comes from Latin’ (it has Latin origin).  
 b. #Hitz hau latin-etik etortzen da  
 word this.ABS latin-ABL come-TZE-INE be.3sgABS  
 Intended: ‘This word comes from Latin’
- (132) a. Botila honek bi ordu daramatza mahai gain-ean  
 bottle this.ERG two year wears table top-INE  
 ‘This bottle is now two hours on the table’, ‘it has been two hours on the table’  
 b. #Botila honek bi ordu erama-te-n du/ditu  
 bottle this.ERG two year wear-TZE-INE have.3sgERG/ have.3sgERG.3plABS  
 mahai gainean  
 table top-INE  
 Intended: ‘This bottle is now two hours on the table’

As can be concluded from these facts, the *-tzen* analytic configurations seems to push a non-atomic interpretation of the event/state, giving rise to the habitual interpretation, as can be seen in (129b), (130c), (131b), (133), (134b) and (135b).<sup>138</sup> The synthetic form, in contrast, remains neutral in this respect.

<sup>137</sup> The interpretation obtained in the analytic configuration seems to vary depending on the speaker. Some speakers also accept the stative reading of *joan* ‘to go’ in the analytic form (p.c. Etxepare).

<sup>138</sup> Note that *-tzen* is also used with non-habitual and non-progressive meaning. The necessary triggering of the plural quantification of stative predicates only occurs in those stative predicates which have an available synthetic form.

## 8.7. CONCLUSIONS AND FURTHER CONSIDERATIONS

### 8.7.1. Conclusions on Asp and the lexicalization of predicates

In this chapter, I have analyzed the factors implicated in the synthetic and analytic distribution of predicates and I have discussed the consequences that these two alignment patterns have for the categorization of the predicate.

Building on Embick (2000), I have argued that when the predicate is lexicalized low –in the first phase domain– it surfaces with nominal category, and that, when it is lexicalized high –in the high functional domain– it surfaces as a verb.

Taking as reference the model developed by D&UE (2000 2004 2005 2014), I have showed that when Asp is defined as AFTER or WITHIN, the predicate is spelled out in complement position of Asp. It is, therefore, lexicalized separately from both Asp and T.

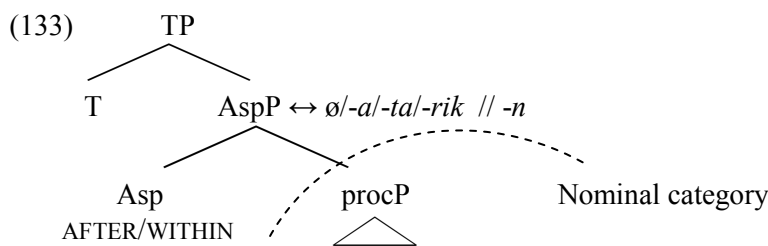

The whole string of elements  $X-tze-n_{\text{WITHIN}}$  and  $X-tu-ta/rik_{\text{AFTER}}$  surface as adpositional phrases or as adverbs. In the case of  $X-tu-a$ , it can be considered an adjective, since it has the ability to agree with its argument.

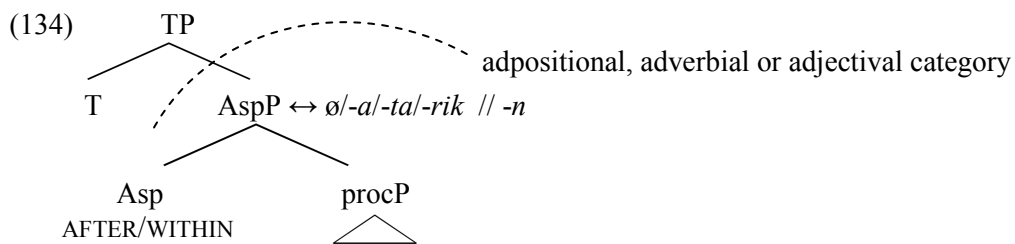

Finally, if Asp is not present and the LI corresponding to the predicate is specified to spell out a head above the first phase domain (e.g. Asp, Mood, etc.), the predicate will be lexicalized high, in the local environment of T, and will surface as a verb.



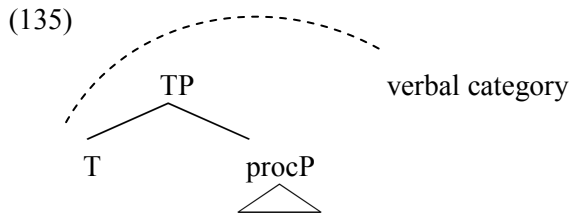

An implication of this analysis is that the verbal category is not syntactically defined, neither as *v* nor as *V*. It rather points out that the verbal category is derived from the lexicalization configuration of the predicate. If it is lexicalized high, in combination with tense and other inflection morphology, it will look as a verb in the surface. Therefore, this proposal is in line with Svenonius (2007), who argues that the uniqueness of verbs reduces to the fact that they combine with tense.

The suffixes *-tu* and *-tze* appearing in the analytic configuration have been claimed in this dissertation to have nominal category. Regarding the latter, I have argued that *-tze* is the exponent of a Classifier/Divisor head (Borer 2005a), responsible for the atomic/non-atomic interpretation of the event and its Ev-T. *-Tu* also fits the nominal category, but its syntactic/semantic contribution is not as clear as that of *-tze*. In a speculative way, I have suggested that *-tu* may be lexicalizing a projection introducing a left boundary (/P).

The ability of a predicate to be spelled out in the local environment of T, as illustrated in (138) has been claimed to be the result of an additional specification in the LIs associated to the predicates. With no Asp, the predicates are free to be lexicalized in the high functional domain. However, in order for that to be possible, the LIs associated with the predicates have to be specified to lexicalize a head belonging to the high functional domain. Some predicates appear in configurations without Asp but are not lexicalized high because their associated LI can only spell out the first phase domain. This is the case of bare analytic predicates (e.g. *maite izan* ‘to love’, lit. have love). In connection to the categorization pattern illustrated above, these predicates consist of elements which are independently used in the language as nouns, adjectives or inessive PPs. The fact that very few predicates can surface in the synthetic configuration in contemporary Basque supports the analysis of this predicates as “quasi-functional”, in the sense that they are lexically related to heads belonging to the high functional domain, out of the first phase.

As the reader may have noticed, the categorization pattern proposed in this chapter is reminiscent of the Generalization on Roots, made in chapter 4, repeated here:

## (136) Generalization on Roots

Roots surface as nominals and need to be case-licensed if they are lexicalized separately from their respective subevent.

In chapter 4 and 5, I have claimed that Roots surface with nominal category if they are lexicalized separately from their respective subeventive node. This relation between being lexicalized separately and surfacing as a nominal seems to be similar to what I have suggested about predicates. If they are lexicalized separately from Asp, they surface with nominal category. Then, in combination with Asp, the predicates can have adjectival or adpositional category, and finally, in combination with tense, they surface as verbs. This analysis on the categorization of predicates is also in line with the decomposition of adjectives and adverbs made in Mateu (2002) and Mateu & Rigau (2002), already commented on in chapter 4, section 5.2. In that analysis, it is claimed that adpositions, adjectives and adverbs share the same argument structure where a relational element (x) takes a non-relational element (y) as complement.

(137) [<sub>xP</sub> z [ x [ y ] ] ]

Applying this to the contexts that I have analyzed in this chapter, we can consider that the relational element is instantiated by the AFTER and WITHIN Asp heads, and the non-relational element is represented by the predicate. The adjectival or adverbial status of participials may be related to this basic relational structure. They are considered to have adjectival or adverbial category because they lexicalize the whole xP (in 137). In the Basque analytic configuration, in contrast, Asp and the predicate are lexicalized separately, so that the nominal category of the predicate becomes apparent in the surface.

Of course, the application of the Generalization in (136) to predicates would yield the following question: do nominal predicates (those headed by *-tu* and *-tze* or bare predicates like *maite*) be case-licensed? If the answer is yes, then, some case-licensor has to be posited to be present. In the case of the configurations where Asp is active, the spatiotemporal predicates WITHIN and AFTER can be taken to be suitable licensors. As I did with result verbs which had an overt adposition lexicalizing the result subevent (*-ra-* in *etxe-ra-tu* ‘to go / take sb home’ and *ka* in *sail-ka-tu* ‘to classify’) (see section 5.4.2), we can think of the aspectual operators WITHIN and AFTER as adpositions licensing the nominal predicate. The case of the configurations where Asp is not active is more problematic, though. Consider a bare predicate like *maite izan* ‘to love’ and a *-tu* headed predicate in the perfective configuration:

- (138) a. Ni-k zu maite zaitut  
 I-ERG you.ABS love have.1sgERG.2sgABS  
 ‘I love you’  
 b. Amets etorr-i zen  
 Amets.ABS come-TU be.3sgABS  
 ‘Amets came’

In these configurations, I have claimed that Asp is not projected. We can think, then, that the next spatiotemporal predicate, namely T, defined as WITHIN in (141a) and as AFTER in (141b), licenses these nominal predicates.

Before finishing this chapter, I want to make some comments on the way in which future tense is constructed in Basque, since it is relevant for some aspects discussed so far.

### 8.7.2. Future tense

Future tense in Basque consists of a predicate headed by *-tu* and an additional morpheme *-ko* or *-(r)en*, plus the auxiliary in present tense.

- (139) Irati-k fandangoa dantza-tu-ko du  
 Irati-ERG fandango.ABS dance-TU-GEN have.3sgERG.3sgABS  
 ‘Irati will dance the fandango’

As mentioned in section 5.3, both *-ko* and *-en* are homophonous with the the genitive. The distribution of *-ko/-en* suffixes is mainly dialectal, although *-en* only attaches to predicates whose infinitive/participial form (the *-tu* suffix and its variants) ends in a *-n* or *-l*. In this way, predicates ending in *-n* (e.g. *egin* ‘to do’, *joan* ‘to go’) are combined with *-go* (allomorph of *-ko*) in Bizkaian and Guipuzkoan (western and central varieties in Zuazo’s terms 2008) *-egingo* and *joango-* and *-en* in the rest of the dialects (north-eastern varieties) (*eginen* and *joanen*) (Hualde 2003a: 206). According to Euskaltzaindia (1997[1987]:116), as we move to the East, the distribution of *-en* over predicates is broader, attaching to predicates also ending in *-tu* and *-i*. In those cases, an intervocalic *-r-* is introduced between the *-tu* and *-en*: *sartu-r-en* ‘enter-EN’, *etorri-r-en* ‘come-EN’. Mounole (2011) points out that, in earlier stages of the language, *-(r)en* used to be broadly used instead of *-ko* in north-eastern varieties. In this section, I will use *-ko* to make reference to both morphemes.

The positioning of this suffix represents another piece of evidence to prove that the *-tu* morpheme does not lexicalize the Asp head (Haddican 2007 and Haddican &

Tsoulas 2012), but just the predicate having nominal category, to which the future denoting *-ko* is attached.

In the following lines, I will discuss the status of *-ko*: some points that can be considered to support an aspectual view of these suffixes, and some points against it, and supporting in contrast, a modal approach. In the development of the discussion, some interesting issues will emerge.

8.7.2.1. THE ASPECTUAL STATUS

According to Lafon (1972/1999), Oyharçabal (1987) and Mounole (2011), the *-ko* suffix used to convey destination at an earlier stage of the language and it obtained subsequently a future temporal meaning. Thus, it is similar to the Spanish *estar para venir* ‘be to come’, which uses the destinative adposition *para* and which has a future value, a pattern attested cross-linguistically. For instance, in contemporary Basque, destinative clauses are headed by the *-tze-ko* sequence of LIs, and intended future events can also be conveyed by *-tze-ko-a*:

- (140) a. *Liburua har-tze-ko etorri naiz*  
 book.ABS take-TZE-GEN come-TU be.1sgABS  
 ‘I have come in order to take the book’
- b. *Etor-tze-ko-a naiz*  
 come-TZE-GEN-DET be.1sgABS  
 ‘I intend to come’ lit. ‘I am to come’

In this chapter, I have suggested that *-tu* and *-tze* have nominal category. It could be thought that, both destinative and future tense configuration consist of the same underlying spatiotemporal ordering predicate. As a matter of fact, this analysis of *-ko* is in accordance with the model defended by D&UE (2000 2004 2005), where future or prospective tense/aspectual meaning is defined in terms of a [-central, +centripetal coincidence] head; BEFORE. Within this approach, in future tense, T head orders the Ut-T *before* the Ast-T, and in the prospective aspect, Asp orders the Ast-T *before* the Ev-T.

- (141) a. Future tense  
 UT-T *before* AST-T  
 — [ ] — [ ] —>  
 UT-T      AST-T
- b. Prospective aspect  
 AST-T *before* EV-T  
 — [ ] — [ ] —>  
 AST-T      EV-T

Basing on this model, then, we could posit that *-ko* spells out a head of [-central, +centripetal coincidence]. For instance, Euskaltzaindia (1997[1987]) considers that it is an aspectual head realizing [+future, -bound] feature. In the same line, other works (e.g. Hualde 2003a: 206, de Rijk 2008: 142) have taken *-ko* headed predicates to be future or prospective participles.

But, is it really an instance of an aspectual head or of a tense head? As I have shown, simple future forms consist of an auxiliary in present tense and a *-ko* headed predicate. According to D&UE (e.g. 2000: 195), simple future tense involves a T head BEFORE and a morphologically empty Asp head. Since Asp is empty, the relation between the Ast-T and the Ev-T is resolved in an anaphoric way and the Ev-T gets indirectly ordered in the future.

(142) Simple future tense

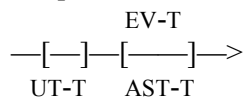

Within this analysis, we would need to posit that *-ko* is the exponent of T. This would be problematic, though, since, in Basque both *-ko* and tense are morphologically realized: *-ko* heading the predicate and tense on the auxiliary. Furthermore, *-ko* is also used in past prospective environments, where, in any case, it would lexicalize the Asp head:

(143) Iratik fandangoa dantza-tu-ko zuen  
 Irati-ERG fandango.ABS dance-TU-GEN have.3sgERG.3sgABS.PST  
 ‘Irati was going to dance the fandango’

(144) Past prospective

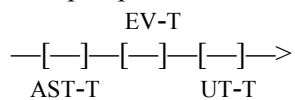

In this case, the tense is past, so that T must have ordered the Ut-T *after* the Ast-T. *-Ko*, then, must be the exponent of the Asp BEFORE head.

#### 8.7.2.2. THE MODAL STATUS

The modal status of *-ko* has been defended in Laka (1995 2006a) who argues that it has an irrealis value. This consideration is mainly supported by the fact that *-ko* predicates occur in a variety of contexts, apart from future or prospective categories.

They also occur in the first part of conditionals (145a) and in the consequence of conditionals (145ab). Additionally, it is also used to denote probability (146), (Hualde 2003a, Laka 1995 2006a, Jendraschek 2014).

- (145) a. London-era joa-n-go banintz, British museoa bisita-tu-ko nuke  
 London-ALL go-TU-GEN were, British museum.ABS visit-TU-GEN would  
 ‘If I went to London, I would visit the British museum’  
 b. Zu banintz, ur gehiago edan-go nuke  
 you.ABS were, water more.ABS drink-TU-GEN would  
 ‘If I were you, I would drink more water’
- (146) [Ez ditut giltzak topatzen]. Etxe-an ahaz-tu-ko nituen  
 [I don’t find my keys]. home-INE forget-TU-GEN have.1sgERG.3plABS.PST  
 ‘I don’t find my keys. I must have forgotten them at home’

The sentence expressing probability is identical to the past prospective form addressed in the previous section. In this respect, it is remarkable that all past prospective sentences can be followed by the negation of the event itself, as in the following sentence:

- (147) Irati-k fandangoa dantza-tu-ko zuen, [baina azkenean  
 Irati-ERG fandango.ABS dance-TU-GEN have.3sgERG.3sgABS.PST [but at the end  
 ez zuen dantzatu]  
 she didn’t]  
 ‘Irati was going to dance the fandango, but at the end, she didn’t]’

This follows from the fact that what is really asserted in that sentence is that Irati was in a situation preceding the event of she dancing the fandango, but not that she actually danced it. Similarly, past prospective sentences can also function as consequences of a conditional, if it would be preceded by a sentence such as ‘If I had brought her her dress’:

- (148) [Bere soinekoa ekarri izan banio], Irati-k fandangoa dantzatu-ko  
 [If I had brought her her dress] Irati-ERG fandango.ABS dance-TU-GEN  
 zuen  
 have.3sgERG.3sgABS.PST  
 ‘If I had brought her her dress, Irati would have danced the fandango’

Both the first and the second part of this conditional have a counterfactual meaning: they denote a hypothetical condition in the past and a hypothetical consequence of that condition. Neither of them has actually taken place.

The clauses in (145ab) are also conditional, but not counterfactual. They denote hypothetical events anchored in the present. As can be seen, the suffix *-ko* appears

both in the first part of the conditional<sup>139</sup> and in the consequence of the conditional. In these cases, the clauses constituting the consequence of the conditional involve the spelling out of the morpheme *-ke-* on the auxiliary, usually glossed as a mood morpheme.

It seems, then, that the meaning of *-ko* is closely related to modality, especially in the presence of *-ke-* on the auxiliary. The multifunction feature of the *-ko* suffix is not a rare characteristic of Basque.<sup>140</sup> As a matter of fact, it has been cross-linguistically observed that future forms in many languages have evolved from modal expressions or constructions with original meanings related to obligation, desire (e.g. English ‘will’), probability etc. and that some markings are used in a single language to convey more than one of these meanings. According to Comrie (1985: 43), future tense is necessarily more speculative than the past and the present, since any prediction made about the future can be changed by intervening events. Thus, Comrie suggests that the difference between future and past and present tenses might be regarded as a difference of mood, rather than of tense (see also Lyons 1977). According to Jendraschek (2014: 23), future time reference constitutes an area of overlap between tense and reality marking. It locates an event at a point in time ahead of the speech situation, but by doing so it anticipates a world that is not yet real.<sup>141</sup>

<sup>139</sup> In (145b), *-ko* does not appear in the first part of the conditional since the verbal form is synthetic. If we would use an analytic form, as in *zu izango banintz* ‘if I were you’, the *-ko* suffix would head the predicate *izan* ‘be’.

<sup>140</sup> In this respect, Basque used to make use of the *-ke* morpheme in texts dating from the 15<sup>th</sup> and 16<sup>th</sup> centuries in order to express future tense. According to Mounole (2011: 71), future could be conveyed in analytic configurations, among others, either with (xlviii.a) a non-*-ko* form in the verb (the verb stem, *-tu* or *-tzen*) and an auxiliary with *-te/-ke* morpheme (*izan/\*edun* or *\*edin/\*ezan*) or with (xlviii.b) a *-ko* form of the verb and an auxiliary without *-te/-ke*. Additionally, in two north-eastern authors (Leizarraga and Etxepare) there are also future forms consisting of both the *-ko* headed predicate and the auxiliary with *-te/-ke* (xlviii.c).

(xlviii) a. Gutietsak handikerai, sor dezakek bekaizkeria (Oih. Proc. 618) «Méprise la vanité, tu apprivoiseras Pénurie» (Mounole 2011: 72)

b. Egun tempestate eginen du (Leiz. Mat. XVI, 3) (Mounole 2011: 74)

c. Orduan haren etchea pillaturen duque (Leiz. Mat. XII, 29) «il pillera son bien» (Mounole 2011: 75)

As pointed out by Mounole, the analytic configurations consisting of *\*edin/\*ezan* auxiliaries with *-te/-ke* morphemes (xlviii.a) have also the function of potential modals (it is actually their only function in modern Basque). Regarding later texts, Mounole (2011: 189) notes that the analytic configuration consisting of the *-ko/-en* form of the predicate plus *izan/\*edun* auxiliary without *-te/-ke* (xlviii.b) becomes the most usual form. Nowadays, this latter configuration is actually the only analytic configuration used for that end in contemporary Basque.

<sup>141</sup> In this respect, it is also interesting to point out the similarities that *-ko* future forms have with the Spanish ‘haber<sub>AUX</sub> de<sub>PREP</sub> + infinitive’. This configuration is used in Spanish to convey epistemic probability (xlix) or obligation (l) (see Bosque 2009-2011: 2140-2150).

The hybrid aspectual/modal nature of *-ko* is also evidenced by another piece of data. In chapter 7 and in the present chapter (sec. 8.5.2), I have shown that bare analytic predicates cannot be directly modified by aspectual heads. On the one hand, if they are headed by *-tu*, the predicate becomes eventive, and if they are left bare, they do not trigger a perfect interpretation. On the other hand, they cannot be either directly combined with *-tzen*. Now, some of these predicates are surprisingly compatible with *-ko* (Euskaltzaindia 1997[1987]: 159-164). Those consisting of nouns and adjectives are able to be headed by *-ko* (e.g. *balio-ko*, *behar-ko*, *nahiago-ko*) but not the bare predicates consisting on an inessive PP (e.g. *\*gogoan-ko*, *\*begitan-go*):

- (149) a. Sarrerak hiru euro balioko du [Berria, 2004-06-03]  
 ticket-ERG three euro value-GEN have.3sgERG  
 ‘The ticket will cost three euros’  
 c. EHU-ko sentsibilitateak bildu behar-ko ditu errektoreak  
 EHU-GEN sensitivities.ABS gather-TU need-GEN have.3sgERG dean-ERG  
 ‘The dean will have to gather the different sensitivities of EHU’  
 [Berria, 2004-04-01]

There are two ways to handle this fact. Firstly, we can consider that it is not the Asp head itself what is incompatible with bare analytic predicates, but just the aspectual head AFTER and WITHIN. In this way, we can still consider that *-ko* is an aspectual head (although this would yield problems with its additional modal nature). Secondly, we can just suggest that *-ko* is not an aspectual head at all, and that it represents a higher functional head, such as Mood.

- 
- (xlix) Un trabajador de esta empresa ha de ganar [unos mil dólares por mes] *Probability*  
 A worker of this company has of win [about two thousand dollars per month]  
 ‘A worker of this company must win two thousand dollars per month’  
 (l) Has de repetir el ejercicio *Obligation*  
 Have of repeat the exercise  
 ‘You have to repeat the exercise’

Interestingly, it is also used in classic European Spanish and in contemporary American Spanish to convey future events. Bosque points out (2009-2011: 2146) that the use of this configuration with prospective value is particularly strong in Mexico, Central America and Antilles. Additionally, he points out that it is also spreading in north-eastern Spain, due to the influence of the Catalan language.

The similarity between the Basque future tense configuration and other ‘have<sub>AUX</sub> of<sub>PREP</sub> + infinitive’ European (western) languages was also commented by Mitxelena (1981[2011]:533):

El paralelo pasa por las formas analíticas, llamadas entre nosotros perifrásticas, del verbo, tanto en *perfectum* como en futuro: *etorri da, egin du, est venu, ist gekommen* (ant. *es venido*) / *ha hecho, a fait, hat gemacht; joanen, joango da*, lit. ‘es de ir’, *eginen, egingo du* ‘ha de hacer’.





## **9. Conclusions**



## **9.1. SUMMARY OF THE MAIN CONTRIBUTIONS OF THE DISSERTATION**

In this dissertation, I have analyzed the event decomposition, lexicalization and categorization of Basque predicates. I have argued that predicates can be decomposed into more basic components, namely, processes, states and Rhemes, and that these three elements are not related to syntactically defined categories. Instead, I have shown that these elements may surface with different categories, depending on how they are lexicalized. Thus, in this dissertation, I have argued that syntax does not determine entirely the categorial status of syntactic objects, but, instead, I have suggested that categories are defined in terms of both syntactic structure and post-syntactic lexicalization-configuration. This way, this dissertation has offered a novel approach to the study of event decomposition, relating it to lexicalization, categorization and to viewpoint aspect.

### **9.1.1. Subevents and temporal interpretation**

There are two types of subevents: processes and states. Processes introduce an event argument, a spatiotemporal variable, whereas states are mere central coincidence relations which introduce arguments –participants– and relate it to a property.

In the analysis that I have presented in this thesis, I have argued that all subevents need to take a complement, so that when a subevent  $e_1$  merges with another subevent  $e_2$ ,  $e_2$  will necessarily be combined with something else. In other words,  $e_2$  cannot be in the tail of the syntactic structure. I have proposed that that position is actually occupied by Rhemes. Rheme objects do not constitute subevents by themselves, but instead, fulfill the function of describing and measuring the subevent they complement. In this way, I have argued that the Merge operation carried out between two subevents and between a subevent and a Rheme is interpreted in two different ways. When two subevents are merged, the relation between them is interpreted as identification, so that the externally merge subevent is interpreted as implicating or leading to the subevent in complement position. In contrast, when a subevent merges with a Rheme, their relation is stated as identification. I have defined identification as a homomorphic relation, where the structure associated to the Rheme is mapped to the structure of the subevent. Thus, for each point in the measure denoted by the Rheme, it is assigned a point or a sub-subevent of the subevent. This mapping has different outcomes, depending on the type of subevent involved in the identification. When the

homomorphism holds between a process subevent and a Rheme, the mapping that takes place assigns to each point of the measure an interval of the temporal structure of the process and vice versa.

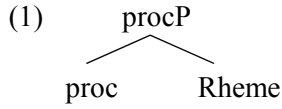

(2)  $\text{RHEME}(p, e) =_{def} \forall e \forall t' \forall p [R(e, p) \cap t' \subseteq \tau(e) \rightarrow \exists i [i \subseteq p \cap R(t', i) (\text{mapping to measures}) \cap \forall e \forall p \forall i [R(e, p) \cap i \subseteq p \rightarrow \exists t' [t' \subseteq \tau(e) \cap R t', i (\text{mapping to events})]]]$

On the other hand, when a Rheme is mapped to a state, each point of the measure will be put within a central coincidence relation.

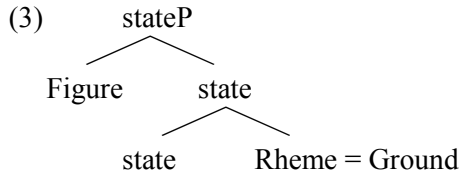

The Rheme of the state is interpreted as the Ground of the central coincidence relation, and if the measure associated to the Rheme denotes a scale where each point is different from the others, the mapping from this measure to the state will yield multiple central coincidence relations. Crucially, when such a state is merged with a process subevent, the transition to the state will be interpreted as gradual.

In this way, the type of measure denoted by the Rheme will invariably have consequences for the temporal structure of the entire predicate. In this dissertation, I have defined the different types of measures according to three properties: [ $\pm$ incremental], [ $\pm$ lower bound] and [ $\pm$ upper bound]. From these binary properties, I derived four different types of measures:

Table 9.1. Types of measures

| — + + + + +                                                                    | — — — — — +                                                                  | — — + + — —                                                         | + + + + +                                                             |
|--------------------------------------------------------------------------------|------------------------------------------------------------------------------|---------------------------------------------------------------------|-----------------------------------------------------------------------|
| + incremental<br>+ lower bound<br>– upper bound<br>(mono-transitional)         | + incremental<br>– lower bound<br>+upper bound<br>(mono-transitional)        | – incremental<br>+ lower bound<br>+upper bound<br>(bi-transitional) | – incremental<br>– lower bound<br>– upper bound<br>(non-transitional) |
| <i>etxerantz</i> ‘towards<br>home’, <i>handi</i> ‘big’,<br><i>kanta</i> ‘song’ | <i>etxeraino</i> ‘up to<br>home’, <i>lehor</i> ‘big’,<br><i>txiza</i> ‘piss’ | <i>bozka</i> ‘vote’, <i>salto</i><br>‘jump’                         | <i>distira</i> ‘shine’,<br><i>elurra</i> ‘snow’                       |

Incrementality and transitionality (having lower and/or upper bounds) has been considered properties of multivalued Rhemes, i.e. Rhemes that, when they are merged with a process subevent give rise to a dynamic event. When monovalued measures (i.e. non-incremental and non-transitional measures, e.g. *distira* ‘shine’) are mapped to the process, the resulting predicate is non-dynamic.

As commented above, Rhemes do not correspond straightaway to a certain category. For instance, the function fulfilled by Rhemes can be carried out by DPs, PPs and even Roots. Roots have been classified in different groups depending on whether they name an Event, a Property or a Thing, and depending on the type of measure associated to them.

**Table 9.2.** Ontology of Roots

| <b>Event naming Roots</b>    |                          |                        |
|------------------------------|--------------------------|------------------------|
| + incremental                | – incremental            | – incremental          |
| + lower bound                | + lower bound            | – lower bound          |
| – upper bound                | + upper bound            | – upper bound          |
| mono-transitional            | bi-transitional          | non-transitional       |
| <i>kanta</i> ‘song’          | <i>bozka</i> ‘vote’      | <i>distira</i> ‘shine’ |
| <b>Property naming Roots</b> |                          |                        |
| + incremental                | + incremental            | – incremental          |
| + lower bound                | – lower bound            | – lower bound          |
| – upper bound                | + upper bound            | – upper bound          |
| mono-transitional            | mono-transitional        | non-transitional       |
| <i>handi</i> ‘big’           | <i>lehor</i> ‘dry’       | <i>ama</i> ‘mother’    |
| <b>Thing naming Roots</b>    |                          |                        |
| + incremental                |                          | – incremental          |
| – lower bound                |                          | – lower bound          |
| + upper bound                |                          | – upper bound          |
| mono-transitional            |                          | non-transitional       |
| <i>bazkal</i> ‘lunch’        | <i>txiza/pixa</i> ‘piss’ | <i>izerdi</i> ‘sweat’  |

Property naming Roots are combined in syntax with state subevents, whereas Event and Thing naming Roots are combined with process subevents. In this way, the dynamicity, gradability and telicity of a predicate is derived in this system from (i) the type of Root (whether if it names an Event, a Property or a Thing–, and from (ii) the properties of the measure associated to the Root. For example, this system expects that two Property naming Roots like *handi* ‘big’ and *lehor* ‘dry’ behave differently in telicity test:

- (4) a. Zuloa bi minutu-tan handi-tu da  
hole.ABS two minutes-INE big-TU be.3sgABS  
‘The hole has got big in two minutes’  
b. Zuloa bi minutu-z handitu da  
hole.ABS two minutes-INTR big-TU be.3sgABS  
‘The hole has got bigger for two minutes’
- (5) a. Arropa bi mintutu-tan lehor-tu da  
clothes.ABS two minutes-INE dry-TU be.3sgABS  
‘The clothes have dried in two minutes’  
b. \*Arropa bi minutu-z lehor-tu da  
clothes.ABS two minutes-INTR dry-TU be.3sgABS  
‘\*The clothes have dried for two minutes’

This contrast emerges because the measure associated to *handi* ‘big’ has not an upper bound, whereas that related to *lehor* ‘dry’ does (see e.g. Hay et al. 1999). On the other hand, even if *handi* does not have an upper bound, it can give rise to a telic interpretation (4a), because *handi* is a Property naming Root, and, thus, it combines with state subevents. When a process subevent selects for a state subevent, the implication relation established between them yields a change of state meaning. Thus, even if *handi* does not have an upper bound, it is involved in an event configuration where the subject undergoes a transition, and thus, can behave in a telic way in some contexts.

With Thing and Event naming Roots the situation is different. Thing and Event naming Roots are combined with process subevents, so that they do not syntactically entail a transition. Thus, whether the measure associated to the Root has or not an upper bound is determinant for the telicity of the predicate. For instance, a morphological complex predicate like *bizarra egin* ‘to shave the beard’ has a telic interpretation, because the measure associated to *bizarra* ‘beard’ has an upper bound. In contrast, another complex predicate like *izerdi egin* ‘to sweat’ is atelic, because *izerdi* ‘sweat’ does not have an upper bound.

- (6) a. Aingeru    bizarra egi-te-n    ari    da     $\Rightarrow$  Aingeru-k    bizarra egin  
       Aingeru.ABS beard    do-TZE-INE PROG be.1sgABS    Aingeru-ERG beard    do-TU  
       du  
       have.3sgERG  
       ‘Aingeru is shaving his beard’  $\Rightarrow$  ‘Aingeru has shaved his beard’  
   b. Aingeru    izerdi egi-te-n    ari    da     $\Rightarrow$  Aingeruk    izerdi  
       Aingeru.ABS sweat do-TZE-INE PROG be.1sgABS    Aingeru-ERG sweat  
       egi-n    du  
       do-TU have.3sgERG  
       ‘Aingeru is pissing’  $\Rightarrow$  ‘Aingeru has pissed’

In this way, this analysis has been able to explain the different temporal properties of both change of state predicates (their gradability and telicity) and transitive/unergative predicates (their dynamicity and telicity).

### 9.1.2. The verbal category and the categorization of Roots

The decomposition of predicates into more basic components has been then combined with the analysis of how these components are externalized. To explain the lexicalization of syntactic heads, I have assumed Phrasal Spell Out, a principle



assumed within the Nanosyntax project (e.g. Fábregas 2007, Starke 2009 2014, Caha 2010, Pantcheva 2011).

(7) Phrasal Spell Out (Pantcheva 2011: 106)

Lexical insertion can target phrasal nodes.

According to this principle, a given LI  $\alpha$  can lexicalize a phrase like AP, if the whole phrase AP is stored in the lexical entry of  $\alpha$ :

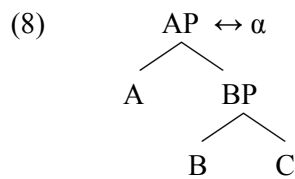

Basing on this principle of lexicalization, I made a Generalization about the categorization of Roots. In a situation where a Root is occupying the Rheme position of a subevent, if both the subevent and the Root are spelled out at once inserting an LI in the phrasal node of the subevent, the Root will not surface as a noun. But, if the Root and the subevent are lexicalized separately the Root will surface as a noun.

(9) Generalization on Roots

Roots surface as nominals and need to be case-licensed if they are lexicalized separately from their respective subevent.

This Generalization has been made in the context of morphologically complex unergative predicates. By means of this Generalization, I have accounted for the inability of these predicates to take other internal arguments apart from the Root itself. The Root surfaces as a noun, and, thus, it has to be case-licensed. Therefore, complex unergative predicates are incompatible with other overt PATH objects or target-like objects.

(10) Irati-k (\*fandango) dantza egin du  
 Irati-ERG (\*fandango.ABS) dance do-TU have.3sgERG.3sgABS  
 Intended: 'Irati has danced the fandango'

(11) Irati-k (\*Jone) bultza egi-n du  
 Irati-ERG (\*Joneo.ABS) push do-TU have.3sgERG.3sgABS  
 Intended: 'Irati has pushed Jone'

That the separately realized Root is occupying the Rheme position of the process is further supported by the fact that complex unergatives, in contrast to simple ones, cannot be combined with telicizing allative phrases (Etxepare 2003).

- (12) Jon-ek mahaia-ri (\*bazzerr-era) bultza egi-n zion  
 John-ERG table-DAT (\*corner-ALL) push do-TU have.3sgERG.3sgDAT.PST  
 Intended: ‘John has pushed the table to the corner’
- (13) Jonek mahaia bazterr-era bultza-tu zuen  
 John-ERG table.ABS corner-ALL push-TU have.3sgERG.3sgABS.PST  
 ‘John has pushed the table to the corner’

In simple predicates, like *bultzatu* in (13), the LI *bultza* has been inserted in the phrasal node [<sub>procP</sub> proc], and this way, the Rheme element –in this case, the allative phrase– can be independently lexicalized.

The principle of phrasal spell out has been also very useful when analyzing the change of location predicates built on allative adpositions, e.g. *etxe-ra-tu* ‘to go/take sb home’, *auzi-pe-ra-tu* ‘to prosecute’ etc. In an analysis of these predicates à la Hale & Keyser (1993), where a silent V would be posited to select for the allative PP (e.g. Oyharçabal 2003), it cannot be explained why change of location predicates are only built on allative adpositions and not, for example, on other type of path adpositions like the Source (ablative) *-tik* or the approximative *-rantz*. Basing on this restriction, I have claimed that the allative *ra* is inserted directly in the position of the process subevent, precisely because procP and GoalP (Pantcheva 2011) are topologically and structurally isomorphic. Thus, the allative *ra*, which usually lexicalizes [<sub>GoalP</sub> Goal [<sub>PlaceP</sub> Place]], in change of location predicates spells out the whole phrase [<sub>procP</sub> proc [<sub>resP</sub> res]].

This analysis implies that there is not a silent V in this kind of derived predicates, and furthermore, it also points out that the process subevent is not syntactically defined as verbal, since it can be spelled out by an LI which usually lexicalizes an adposition. Besides, in this dissertation I have shown that *proc* is in many derived change of state predicates lexicalized by the *-tu* suffix (e.g. “denominal” predicates like *ama-tu* (mother-TU) ‘to become a mother’, “deadjectival” predicates like *lehor-tu* (dry-TU) ‘to dry’ and *etxe-gabe-tu* (house-without-TU) ‘to evict’, or deadpositional predicates like *ur-ez-ta-tu* (water-INSTR-TA-TU) ‘to water’. Since the *-tu* suffix is apparently turning its complements into predicates of change of state, someone can consider that *-tu* is actually a verbalizer with a GO or BECOME flavor. However, *-tu* headed predicates can occur in nominal contexts, such as within DPs (14) and within

PPs (15), and this fact suggests that *-tu* fits better the nominal category, rather than the verbal one.

- (14) a. *begira-tu bat*  
 look.at-TU DET  
 ‘a look’  
 b. *uki-tu bat*  
 touch-TU DET  
 ‘a touch’  
 c. *har-tu- ema-n-a-k*  
 take-TU-give-TU-DET-pl  
 ‘interchange, relation, lit. to take-to give’  
 d. *joa-n- etorr-i-a-k*  
 go-TU-come-TU-DET-pl  
 ‘round trip, lit. to go-to come’
- (15) a. *Erabili-z ikas-te-n da*  
 use-TU-INSTR learn-TZE-INE is  
 ‘you learn by using’  
 b. *Miren etorr-i oste-an,...*  
 Mary.ABS come-TU back-INE  
 ‘After Mary comes’, lit. ‘in the back of Mary coming’  
 c. *Miren etorr-i gabe*  
 Mary.ABS come-TU without  
 ‘Without Mary coming’

Thus, a verbal category or a verbalizer function cannot be posited to *-tu*. *-Tu* is used in the citation form of the predicates, in some non-finite contexts and in the perfect/perfective analytic configuration. Another LI that could perhaps be considered to be an instance of little *v* is *-tze*, the suffix heading predicates in other non-finite contexts and in the analytic imperfective configuration. Nevertheless, *-tze* is standardly assumed to be a nominalizer, so that once again, the suffix heading the predicate does not fit within the verbal category, but rather, seems to have nominal category.

All in all, this data points out that the verbal category, either as *V* or as *v*, is not easily identified in Basque, since all the LIs lexicalizing the predicate or parts of it have other category rather than the verbal one. What this analysis implies is that the verbal category must be divorced from the first phase syntax or from a particular syntactic head. Instead, I claim that the verbal category is a post-syntactic configurational notion which emerges if the predicate is lexicalized out of the first phase syntax and in combination with tense.

### 9.1.3. The boundary between stativity and eventivity

In this dissertation, I have also been concerned with the stative or eventive nature of the predicates. To be more precise, I have analyzed the syntactic projections involved in making a predicate be eventive/stative-like and how these configurations interplay with the introduction of arguments.

The discussion on eventivity and stativity has been hold in relation to certain predicates which in previous literature had been identified as problematic, i.e. being stative but behaving like eventive in the tests used to differentiate eventive from stative predicates (Dowty 1979, Maienborn 2005 2007, Rothmayr 2009, Fábregas & Marín 2012), e.g. *lie, sit, stand, shine* etc. These predicates contrast with canonical stative predicates like *know, weigh, resemble, own* etc. Following the terminology used in some of the works cited, I have called the former type of predicates D-states, and the latter type K-states.

As proposed in Fábregas & Marín, I have claimed that, in D-states, a process subevent is projected, and that in K-states is not. The stative-like interpretation obtained in several linguistic tests of D-states is due to the fact that, in D-states, the process subevent selects for a Rheme –not for a state subevent–, and crucially, this Rheme is associated to a [–incremental] and [–transitional] measure. This yields an eventive but non-dynamic predicate.

Recall that in my analysis, the process subevent introduces an event argument, whereas the state subevent is a central coincidence relation which introduces a subject participant in its specifier. Following Ramchand (2008a), I have claimed that depending on how the state subevents are combined with a process subevent, they can be interpreted as initiation or as result subevents.

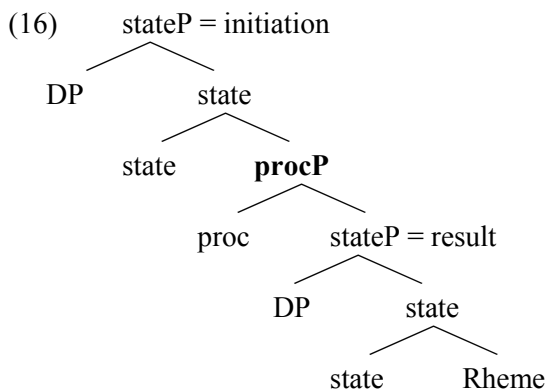

The analysis of the introduction of subjects in combination with the analysis of D- and K-states has been able to explain the cross-linguistic contrast found between intransitive D- and K-states regarding their unaccusative or unergative alignment (e.g. Sorace 2000 2004). Intransitive D-states are generally unergative across languages, whereas intransitive K-states can be either unergative or unaccusative. In my analysis, unaccusative and unergative predicates are clearly distinguished by the fact that, in unaccusative predicates, the subject is projected in the lower stateP, while in unergative predicates, it is introduced by the higher stateP. If in a given intransitive predicate the process subevent is projected and the subject is introduced in the lower stateP, the predicate would be automatically interpreted as a dynamic change of state. Thus, in intransitive D-states, where process is projected, the subject must necessarily be projected in the higher stateP, giving rise to the unergative configuration.

#### 9.1.4. Viewpoint aspect and categorization

Another area that has been analyzed in this dissertation involves viewpoint aspect. In the last chapter, viewpoint aspect has been explored in relation to the analytic and synthetic configuration of predicates and to the categorization of the predicate. Building on Embick (2000), I have claimed that when a predicate is lexicalized out the first phase syntax, in combination with tense and other inflectional morphology, the resulting configuration is synthetic and the predicate surfaces as a verb. In contrast, when the predicate is lexicalized low, within the first phase, it is realized with nominal category. The former scenario takes place when the head responsible for viewpoint aspect –a spatiotemporal predicate defined as in Demirdache & Uribe-Etxebarria e.g. 2005– is not projected, and additionally, when the LI corresponding to the predicate is specified to lexicalize a head out of the first phase (like an evidential, epistemic or an aspectual head). In contrast, the latter scenario occurs when the viewpoint Asp head is projected (Laka 1993b, Arregi 2000, Arregi & Nevins 2012) or when the LI lexicalizing the predicate is not endowed additionally with a head belonging to the high functional domain, i.e. bare analytic predicates like *maite izan* ‘love’ or *uste izan* ‘have an opinion about’.

The head Asp, defined as a spatiotemporal relational element like WITHIN or AFTER, orders the assertion (Ast-T) time with respect to the event time (Ev-T). When it is projected the predicate has to be lexicalized in its complement position. This has an important consequence for the predicate, namely that it surfaces with nominal

category. In this case, the predicates are headed by *-tu* or by *-tze* (*-n* is the exponent of the Asp head). I have claimed that *-tze* is the exponent of a Classifier/Divisor phase (Borer 2005) responsible for the atomic or non-atomic interpretation of the event, and which result respectively in the progressive or habitual interpretation of the predicate. The head that *-tu* is lexicalizing is not as clear. Speculatively, I have suggested that *-tu* may be spelling out a head projecting a left boundary (*/P*) which would be located lower in the hierarchy projected in nominals.

In another scenario, where Asp is not projected, the predicate can be lexicalized higher –if that information is stored in its lexical entry–. In this case, the predicate will surface with verbal category.

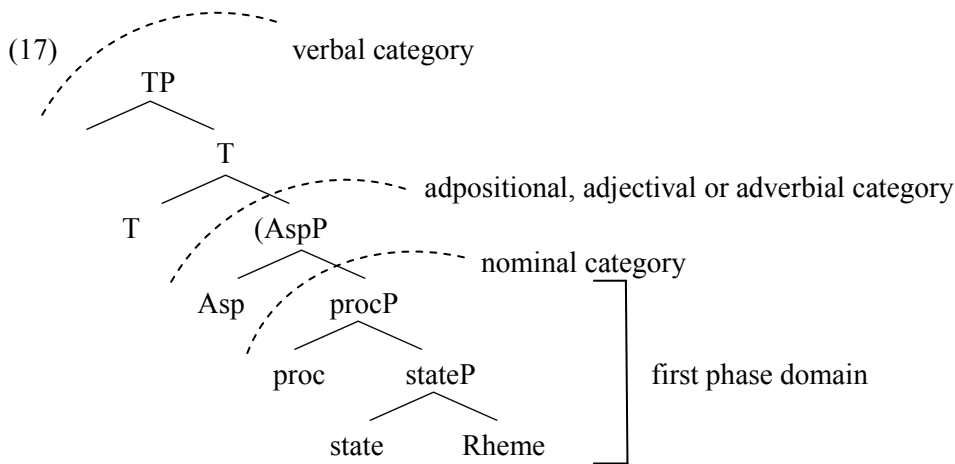

This pattern of categorization is reminiscent of the categorization pattern proposed in the Generalization on Roots (9). Imagine that T is similar to process and that Asp is similar to state. If the Rheme of the state (in this case, the first phase domain) is lexicalized separately from its subevent (the Asp head), then it will surface with nominal category.

On the other hand, in bare analytic predicates like *maite izan* ‘to love’, Asp is not projected, and the predicate (*maite* ‘love’) is directly merged as the “Rheme” of T. Since the Rheme is lexicalized separately from T, the Rheme surfaces with nominal category.

In this story, the only difference between a predicate which surfaces with adjectival or nominal category and a predicate which surfaces with verbal category, is that the latter is lexicalized high in the functional structure and that it is combined with tense morphology. Thus, the verbal category is not syntactically defined or identified in a

single functional head (e.g. little *v*), but it is derived from the configuration in which a predicate is lexicalized.

All in all, it seems that the categorization process is being applied in a recursive manner (see actually Boeckx 2015) and interestingly, it seems that what matters for categorization is not exclusively syntactic structure, but the chunks in which the syntactic nodes are lexicalized. The pattern can be formulated in the following way. If a non-relational element is lexicalized separately from its corresponding relational element, it surfaces as a noun. In contrast, if it is lexicalized together with its relational element, then it surfaces as a non-noun. Regarding the recursive application of the pattern, a relational element and a non-relational element that have been lexicalized together (e.g. the state and the Rheme in *maite* 'love') become a non-relational element when they are in complement position of a further relational element (e.g. T), and can surface with nominal category if the corresponding lexicalization pattern applies.

## 9.2. CONSIDERATIONS FOR THE FUTURE

This dissertation has put some light on many aspects of the “verbal” configuration of Basque, but nevertheless, it has raised many questions that will need to be studied further in future research. Some of these aspects are: (i) the cross-dialectal variation in the use of *-tu* suffix, (ii) the study of languages other than Basque to explore how the decomposition and categorization pattern proposed in this dissertation can account for the cross-linguistic variation, and (iii) the possible implications of the proposal presented for the ergativity and auxiliary selection system of Basque. Some of these questions are commented in this section.

### 9.2.1 Aspects concerning dialectal variation

There are several issues that would need to be studied further from the point of view of dialectal variation. For example, in non-western Basque dialects, in the subjunctive and the potential configurations, the predicate is generally not headed by *-tu*.<sup>142</sup>

- (18) a. Ane etorr-i dadin nahi dut *Simplified western pattern*  
 Ane.ABS come-TU be.3sgABS wish have.3sgERG  
 ‘I want Ane come’  
 b. Ane etorri daiteke  
 Ane.ABS come-TU be.3sgABS(can)  
 ‘Ane can come’
- (19) a. Ane etor dadin nahi dut *Simplified non-western pattern*  
 Ane.ABS come be.3sgABS wish have.3sgERG  
 ‘I want Ane come’  
 b. Ane etor daiteke  
 Ane.ABS come be.3sgABS(can)  
 ‘Ane can come’

In the non-western dialects (and in the standard variety), predicates do not need to be headed by *-tu* either in the subjunctive (19a) or in the potential (19b). There seems to be, however, some contrast among derived and non-derived predicates, at least in standard Basque. According to *Hiztegi Batua* (Euskaltzaindia 2014), derived predicates may take the *-tu* suffix in the above mentioned contexts.<sup>143</sup>

<sup>142</sup> In the subjunctive and in the potential other auxiliary roots are used: *\*edin* and *\*ezan*. *\*edin* is generally used with unaccusative predicates and *\*ezan* with unergatives and transiives. I gloss them as *be* an *have*, since the difference between *izan/\*edun* and *\*edin/\*ezan* is not relevant for the discussion here.

<sup>143</sup> This is indicated in the dictionary in the entry of each predicate. The non-derived predicates which cannot take *-tu* in these contexts (e.g. *etorri* ‘to come’) are listed as *etor*, *etorri*, *etortzen*. In contrast, derived predicates (e.g. *amatu* ‘to become a mother’) are listed as *ama/amatu*, *amatzen*.



- (20) a. Ane ama/ama-tu dadin nahi dut *Standard Basque*  
 Ane.ABS mother/mother-TU be.3sgABS wish have.3sgERG  
 ‘I want Ane become a mother’  
 b. Ane ama/ama-tu daiteke  
 Ane.ABS mother/mother-TU be.3sgABS(can)  
 ‘Ane can become a mother’

The optionality between the *-tu* and the *-tu*-less form covers all type of derived predicates: change of state predicates and just process predicates like *dantzatu* ‘dance’.

- (21) a. Ane-k dantza/dantza-tu dezan nahi dut *Standard Basque*  
 Ane-ERG dance/dance-TU have.3sgERG wish have.3sgERG  
 ‘I want Ane dance’  
 b. Anek dantza/dantza-tu dezake  
 Ane-ERG dance/dance-TU have.3sgERG(can)  
 ‘Ane can dance’

Regarding this contrast between non-derived and derived predicates, Etxepare (p.c.) points out that, in his variety, a predicate like *aberetu* always needs to be headed by *-tu* in the above contexts, whereas another predicate like *lehortu* ‘to dry’ does not need to.

- (22) a. Ez nuke nahi Mikel \*abere/abere-tu dadin Etxepare (p.c.)  
 no would want Michael.ABS \*animal/animal-TU be.3sgABS  
 ‘I wouldn’t want Michael become an animal’  
 b. Arropa lehor dadin nahi dut  
 clothes.ABS dry be.3sgABS wish have.3sgERG  
 ‘I want the clothes dry’

In future research, it would be interesting to study these contrasts in the use of *-tu*. For instance, these contrasting data suggests that *-tu* is playing a different role in derived and non-derived predicates, and that it may have different status cross-dialectally. In chapter 3, I have claimed that *-tu* spells out the process head in derived change of state predicates. Within this analysis, it could then be explained why *aberetu* needs to be headed by *-tu* (22a) in all contexts: *-tu* has to be inserted in order for the *proc* head to be lexicalized. Nevertheless, this system cannot explain, at the moment, why *lehor* ‘dry’ does not need it. It may be related to the fact that the measure associated to the Rheme in *lehor* is an incremental scale (of dryness), whereas the measure of *abere* ‘animal’, in contrast, is non-incremental ([+ + + +]), i.e. non-scalar. The contrast is clearly not due to the “denominal” vs. “deadjectival” nature of the predicates, since some deadjectival predicates like *etxe-gabe-tu* ‘to evict’ need also be combined with *-tu*.

- (23) Ez nuke nahi epailea-k familia hori \*etxe-gabe/etxe-gabe-tu  
 no would want judge-erg family that.ABS \*home-without/home-without-TU  
 dezan  
 have.3sgERG.3sgABS

Once again, it seems that the contrast may be related to the scalar vs. non-scalar nature of the measure associated to the Rheme. All these issues will have to be studied in future research.

### 9.2.2. Cross-linguistic comparison

Another important aspect that needs to be studied in future research is the cross-linguistic variation found in predicate formation. For instance, Basque seems to be different from languages like English and Spanish in its ability to build denominal change of state predicates.<sup>144</sup>

With respect to process predicates –predicates which do not involve a result subevent– denominal predicates are similar in these three languages:

- |      |              |                    |                |
|------|--------------|--------------------|----------------|
| (24) | a. to jump   | from <i>jump</i>   |                |
|      | b. to vote   | from <i>vote</i>   | <i>English</i> |
|      | c. to dance  | from <i>dance</i>  |                |
| (25) | a. salt-a-r  | from <i>salto</i>  |                |
|      | b. vot-a-r   | from <i>voto</i>   | <i>Spanish</i> |
|      | c. bail-a-r  | from <i>baile</i>  |                |
| (26) | a. salta-tu  | from <i>salto</i>  |                |
|      | b. bozka-tu  | from <i>bozka</i>  | <i>Basque</i>  |
|      | c. dantza-tu | from <i>dantza</i> |                |

In contrast, denominal change of state predicates can only be formed in Basque.

- |      |                                             |                            |
|------|---------------------------------------------|----------------------------|
| (27) | a. ama-tu ‘to become/turn sb into a mother’ | from <i>ama</i> ‘mother’   |
|      | b. abere-tu ‘to become brutish’             | from <i>abere</i> ‘animal’ |
|      | c. apaiz-tu ‘to become a priest’            | from <i>apaiz</i> ‘priest’ |

In English and in Spanish, these predicates cannot be transparently built in this fashion. In English, the predicate *to mother* has a rather different meaning from that of *amatu*, i.e. to care or protect like a mother. In Spanish too, *amadrar* or any predicate which take the Root *madr* as its base does not have the change of state meaning conveyed by *amatu*.

<sup>144</sup> I am grateful to Itziar Laka for bringing to my attention this cross-linguistic difference.

At this moment, it is not clear to me what might be the source of this cross-linguistic variation.

### 9.2.3. Relation with ergativity

The analysis made in this dissertation can have some implications for the theories dealing with case-assignment in Basque. In the following lines, I present some interesting aspects.

#### 9.2.3.1. ERGATIVITY AND THE EXTERNAL ARGUMENT

In all the predicates that have been explored in this dissertation, the ergative argument has been considered the subject argument introduced in the specifier of the higher stateP. I have showed that it appears in both eventive and stative predicates alike, and that, consequently, the ergative argument can be either a causer, an actor or a holder.

- (28) a. Amets-ek aldizkaria apur-tu du  $DP_{ERG} = \text{Causer}$   
 Amets-ERG magazine.ABS break-TU have.3sgERG.3sgABS  
 ‘Amets has broken the magazine’
- b. Amets-ek dantza egi-n du  $DP_{ERG} = \text{Actor}$   
 Amets-ERG dance do-TU have.3sgERG  
 ‘Amets has danced’
- c. Amets-ek amama maite du  $DP_{ERG} = \text{Holder (experiencer)}$   
 Amets-ERG grandmother.ABS love have.3sgERG.3sgABS  
 ‘Amets loves granma’

Thus, the ergative argument is not always an agentive argument, as it has been sometimes assumed. I have claimed that this argument is introduced by a state head which I have termed Voice, as in Kratzer (1996) and all the works following her. Crucially, I have suggested that the Voice head in Basque must be understood as a stative head. Building on the characterization of the initiation subevent made in *First Phase Syntax* (Ramchand 2008a), I have argued that depending on the complement of Voice, the interpretation of Voice can vary: when Voice selects for a process subevent, it is interpreted as an initiation and the argument in its specifier as an initiator. In this way, I have accounted for the different interpretations associated with ergative arguments.

Since the ergative argument in Basque is characterized in terms of its generating position the ergative case has been considered a lexical (Oyharçabal 1992) or an inherent case (Holmer 1999, Laka 2006b). For instance, several works, such as Nash (1996), Woolford (2006), Legate (2002 2008), Aldridge (2004) and Torrego (2012), have suggested for other ergative languages that ergative case is really an inherent case related to theta-marking. Particularly, Massam (2002), Woolford (2006), Legate (2002 2008) and Aldridge (2004) have claimed that it is assigned by the head introducing the external argument (Voice or little *v*), which may be also responsible for Case-marking the internal argument.

Nevertheless, this position does not go without problems in Basque. There are some contexts where ergative case does not behave as an inherent case assigned by Voice (see e.g. Rezac et al. 2014). Inherent case is assigned to an argument in its merge position by the head selecting it, so that the argument is “licensed” in the same position where it has entered the syntactic derivation. It is not expected that, for example, this argument needs to maintain a spec-head or an agree relation with another head in order to be licensed. Similarly, a DP which gets inherent case in its generating position cannot change and be assigned a structural case in the course of the syntactic derivation, since inherent case, assigned in merge position, is assumed to be preserved and not altered in subsequent syntactic operations. Thus, an external argument which is marked inherent ergative case is not expected to surface with absolutive case. There are actually some contexts in Basque which suggest that ergative case is not inherent, such as the absolutive marking of subjects in perception predicates (Arteatx 2007) and the restrictions observed in both ergative and absolutive subjects in non-finite contexts.

In another type of approach, several works have suggested that ergative case assignment is second to absolutive in Basque, among others, Ortiz de Urbina 1989, Bobaljik 1993, Laka 1993a, Bittner & Hale 1996, Fernández 1997 and Rezac et al. 2014. Within that approach, in order for an argument be case-marked ergative, another nominal must have been marked absolutive (zero) case before. For instance, in several ergative languages, the subjects of all intransitive predicates, unaccusatives and unergatives alike, are assigned absolutive Case, e.g. Samoan (Bittner & Hale 1996: 31)

- (29) a. sa sasa e le teine le maile *Samoan (transitive)*  
 PST hit [ERG the girl] [the dog]  
 ‘The girl hit the dog.’

- b. sa sola le teine *Samoan (unergative)*  
 PST run.away [the girl]  
 ‘The girl ran away.’

Some of the works cited (Bobaljik 1993, Laka 1993a, Fernández 1997) suggested that the different nominative and ergative case systems were the result of a parametric variation involving the structural Case that must be obligatorily assigned. This is formulated as the *Obligatory Case Parameter* (OCP) in Bobaljik (1993: 6), where X stands for the structural case that must be minimally assigned:

- (30) Obligatory Case Parameter (OCP)  
 a. In N/A languages, CASE X is NOMINATIVE (=ERG)  
 b. In E/A languages, CASE X is ABSOLUTIVE (=ACC)

According to this proposal, nominative and ergative languages are not expected to vary in transitive clauses where two structural case assignments take place. Instead, the variation emerges in intransitive predicates: in nominative languages, nominative Case is obligatorily assigned, whereas in ergative languages, absolutive case must be necessarily discharged.

Thus, in these works, the surface manifestation of ergative case is considered to be the result of a prior absolutive assignment. The view that the ergative Case assignment is dependent on the presence/assignment of another nominal element has also been proposed in other works, not necessarily stated in terms of OCP or a structural case-assignment: Marantz 1991, Bittner & Hale (1996),<sup>145</sup> Rezac et al. (2014), Coon (2010), Etxepare (2013), Baker (in press).

Recall that, in Basque, there is a distinction between intransitive predicates: the subjects of unergative predicates are assigned ergative Case, and the subjects of unaccusative predicates are assigned absolutive Case. Consider the morphologically complex and morphologically simple unergative predicates discussed in chapter 4:

- (31) a. Ane-k dantza egin du  
 Ane-ERG dance do-TU have.3sgERG  
 ‘Ane has danced’  
 b. Ane-k dantza-tu du  
 Ane-ERG dance-TU have.3sgERG  
 ‘Ane has danced’

<sup>145</sup> Bittner & Hale (1996) do not suggest that ergative case is assigned after the assignment of absolutive case, but, nevertheless, claim that the ergative Case assignment takes place in a configuration with a competing nominal argument.

The works that consider that ergative is dependent on a previous absolutive assignment have suggested that unergative predicates are really transitive, in accordance with the original proposal made in Hale & Keyser (1993). For instance, some works (Uribe-Etxebarria 1989, Bobaljik 1993, Laka 1993a and Fernández 1997) have suggested that, in morphologically complex unergative predicates, the complement of the light predicate *egin* represents actually a non-incorporated object (or that it may incorporate after spell out in Fernández 1997) which is assigned absolutive case. The analysis made in this dissertation is also in agreement with that view. According to the Generalization on Roots, repeated here, a Root which is lexicalized separately from its subeventive node surfaces as a nominal and must be case-licensed.

(32) Generalization on Roots

Roots need to be case-licensed if they are lexicalized separately from their respective subeventive node.

Since in morphologically complex unergative predicates, the Root (e.g. *dantza*) is not lexicalized together with *procP* (lexicalized by *egin*), it must be case-licensed. Thus, the assignment of ergative Case to the subject can be considered to be second-to-absolutive.

On the other hand, morphologically simple Basque unergatives behave slightly different. As I showed in chapter 4, Roots like *dantza* ‘dance’ can be part of morphologically simple unergative predicates.

- (33) Irati-k oso ondo dantza-tu du  
 Irati-ERG very well dance-TU have.3sgERG  
 ‘Irati has danced very well’

The approaches maintaining the existence of an OCP, claimed that predicates like (33) also consist of an internal argument. Bobaljik (1993) and Laka (1993a) suggested that the internal argument bearing absolutive case is a non-overt object, while Fernández (1997) argued that it is incorporated after I-syntax but before spell-out. My position is rather different. The Root of a predicate like *dantzatu* ‘to dance’ has been lexicalized together with *procP*, and, in accordance with the Generalization on Roots, it does not need to be case-licensed. Thus, within this approach, morphologically simple unergative predicates do not apparently conform to the second-to-absolutive view of ergative assignment.

## 9.2.3.2. ERGATIVITY AND THE NOMINAL CATEGORY OF THE PREDICATE

In chapter 8, I have claimed that, in the analytic configuration—which is predominant in Basque—, predicates surface with nominal category. Someone can argue that this is actually related to the ergative case system, as it has been done in several works, such as in Johns (1992), Alexiadou (2001) and Salanova (2007).<sup>146</sup> For instance, Johns (1992) argues for Inuktitut that the ergative argument is really the specifier of a passive nominal, formally equivalent to a possessor of a Possessive Phrase. In the same line, Alexiadou (2001), building on Bok-Bennema (1991), suggests that the introduction of arguments in an ergative clause is similar to that of a nominalization. In nominalizations, both the object and the internal subject are introduced similarly, and they contrast with the external argument, which is introduced in a different way. In English, for instance, leaving aside the pre-nominal genitive and focusing on the post-nominal, both the direct object *the manuscript* (34a) and the internal subject *John* (34b) are introduced by a *of* phrase. On the other hand, the external subject *John* is introduced in a *by* phrase (34a). This pattern is attested in several languages, for example in Spanish (35).

- |      |                                                           |                |
|------|-----------------------------------------------------------|----------------|
| (34) | a. The destruction of the manuscript by John              | <i>English</i> |
|      | b. The arrival of John                                    |                |
| (35) | a. La destrucción de la ciudad de Pompeya por el Vesubio  | <i>Spanish</i> |
|      | b. La llegada de los colonos ingleses a América del norte |                |

Thus, in nominalizations, the external argument is introduced in a different fashion, contrasting with internal arguments, i.e. objects and internal subjects. This pattern is parallel to that found in ergative languages (Dixon 1994).

Salanova (2007) has also proposed for the ergativity in in Mëbengokre an analysis based on the nominal category of the predicate. Mëbengokre is a language belonging to the Jê family, spoken in central Brazil. The ergative case system in this language is restricted to certain configurations. For instance, it arises in matrix clauses with perfect interpretation and in subordinate clauses (where negative sentences, complements of perception verbs and sentences involving a manner modifier are included). All of them are considered to involve nominalizations. They contrast with other environments, such as in the perfective or the progressive, where the nominative

<sup>146</sup> In Coon (2010), predicates are also considered to be nominalized in the imperfective, but the ergative marking is not directly derived from it. In that study, the ergative marking is subsumed under the set A marking. Set A marks all external arguments –transitive subjects, unergative subjects and possessors. She shows that genitive and ergative are morphologically identical, but she claims that they are, nevertheless, structurally different.

case system emerges. Salanova (2007) proposes that, while the nominative-accusative system is found in the verbal context, ergativity holds in the nominal domain. Nominalized verbs, however, are not considered to be passives (cf. Johns 1992) but action nominals. In his terms, Mëbengokre is similar to nominative languages like English, with the difference that, in Mëbengokre, nominalizations are used in more linguistic contexts.

There is an interesting relation between what I have proposed for Basque analytic configurations and the analysis of ergativity presented in this section. In chapter 8, I have suggested that, in analytic configurations, the predicate surfaces with nominal category, precisely because the predicate is lexicalized low, in the first phase domain.

However, ergativity in Basque does not correlate with the nominal category of predicates, as it does in other languages such as Inuktitut (Johns 1992) and Mëbengokre (Salanova 2007). In Basque, a subject can be marked ergative both in nominal (analytic) and verbal (synthetic) environments.

- (36) a. Amets-ek amantala ekarri du  
 Amets-ERG apron.ABS bring-TU have.3sgERG.3sgABS  
 ‘Amets has brought the apron’  
 b. Amets-ek amantala dakar  
 Amets-ERG apron.ABS brings  
 ‘Amets brings the apron’

Thus, the ergativity of Basque cannot be accounted exclusively in terms of the nominal category of the predicate.





## References

- Acedo-Matellán, V. 2010. *Argument Structure and the Syntax-Morphology interface. A Case Study in Latin and Other Languages*. Doctoral dissertation. Universitat de Barcelona.
- Alberdi, X. 2003. Euskal aditz mailegatuaren erregimena: hurbilketa', In J.M.Makazaga & B.Oyharçabal (eds.), *P. Lafitteren sortzearen mendemugako biltzarra. Gramatika gaiak*. Iker 14 (I). Bilbao: Euskaltzaindia. 37-60.
- Albizu, P. 2001. Sobre la distribución sintáctica de las formas finitas del verbo vasco: condicionamiento léxico y sintáctico. *ASJU* 35-1: 65-106.
- Alcazar, A. 2002. Aspectual Interpretation in Basque. Ms., University of Southern California, Los Angeles.
- Aldai, G. 2006. Is Basque morphologically ergative? The semantic split-intransitive case marking system of Western Basque. In B. Fernandez & I. Laka (eds.), *Andolin Gogoan. Essays in honour of Professor Eguzkitza*. Leioa: UPV/EHUko Argitalpen Zerbitzua. 117-138.
- Aldai, G. 2009. Euskararen kasu markaketaren aldakortasun dialektala. In B. Fernández, P. Albizu & R. Etxepare (eds.), *Euskara eta euskarak: aldakortasun sintaktikoa aztergai*, supplements of ASJU 52. Donostia: UPV/EHU and Gipuzkoako Foru Aldundia. 5-19.
- Aldridge, E. 2004. *Ergativity and Word Order in Austronesian Languages*. Doctoral dissertation, Cornell University.
- Alexiadou, A. 2001. *Functional Structure in Nominals. Nominalization and Ergativity*. Amsterdam/Philadelphia: John Benjamins.
- Alexiadou, A. & E. Anagnostopoulou. 2008. Structuring Participles. In C.Chang & H.Haynie (eds.), *Proceedings of the WCCFL 26*. Somerville, MA: Cascadilla Press. 33-41.
- Alexiadou, A., Iordachioaia, G., & F. Schäfer. 2011. Scaling the Variation in Romance and Germanic Nominalizations. In P.Sleeman & H.Perridon (eds.), *The Noun Phrase in Romance and Germanic: Structure, variation, and change*. Philadelphia/Amsterdam: John Benjamins. 25-40.
- Anagnostopoulou, E. 2003. Participles and Voice. In A.Alexiadou, M.Rathert & A.von Stechow (eds.), *Perfect Explorations*. Berlin/New York: Mouton de Gruyter.1-36.

- Andrews, A. 1990. Unification and Morphological Blocking. *Natural Language and Linguistic Theory* 8: 507-557.
- Arregi, K. 2000. Tense in Basque. Ms., MIT.
- Arregi, K. 2004. The Have/Be Alternation in Basque. Ms., University of Illinois at Urbana-Champaign.
- Arregi, K. & A. Nevins. 2012. Morphotactics: Basque Auxiliaries and the Structure of Spell-Out. Dordrecht: Springer.
- Arteatx, X. 2007. Euskarazko oharren-aditzen osagarrietako perpaus jokatugabeak. *Uztaro* 63: 21-63.
- Artiagoitia, X. 2003. Complementation. In J. I. Hualde & J. Ortiz de Urbina (eds), *A Grammar of Basque*. Berlin: Mouton de Gruyter. 640-718.
- Artiagoitia, X. 2004. The Case of an Enlightening, Provoking and Admirable Basque Derivational Suffix with Implications for the Theory of Argument Structure. *Supplements of ASJU* 46. University of the Basque Country (UPV/EHU). 147-183.
- Baker, M.C. 1988. *Incorporation. A Theory of Grammatical Function Changing*. Chicago/London: The University of Chicago Press.
- Baker, M.C. 2003. *Lexical Categories. Verbs, Nouns and Adjectives*. Cambridge: Cambridge University Press.
- Baker, M.C. 2014. On Dependent Ergative Case (in Shipibo) and Its Derivation by Phase. *Linguistic Inquiry* 45-3: 341-379.
- Basilico, D. 2010. The *se* Clitic and its Relationship to Paths. *Probus* 22: 271-302.
- Beavers, J. 2008. Scalar Complexity and the Structure of Events. In J. Dolling & T. Heyde-Zybatow (eds.), *Event Structures in Linguistic Form and Interpretation*. Berlin: Mouton de Gruyter. 245-265.
- Bennett, M. & B. Partee. 1972. *Toward the Logic of Tense and Aspect in English*. Bloomington: Indiana University Linguistics Club. Reprinted in Bennet & Partee 2004.
- Bennett, M. & B. Partee. 2004. Toward the Logic of Tense and Aspect in English. In B. Partee, *Compositionality in Formal Semantics. Selected Papers by Barbara H. Partee*. Malden/Oxford: Blackwell.
- Berro, A. 2010. Unergative Predicates in Basque Varieties: Consequences for the Ergative Case Assignment. DEA research work. University of the Basque Country (UPV/EHU).

- Berro, A. 2012. Three Levels of Root Insertion in Basque Intransitive Verbs. In E.Carrilho & B.Fernández (eds.) *Journal of Portuguese Linguistics*. Special Issue, 11-1. Edições Colibri-Universidade de Lisboa. 7-22.
- Berro, A. & R. Etxepare. To appear. Ergativity in Basque. In J.Coon, L.M.Travis & D.Massam (eds.), *The Oxford Handbook of Ergativity*. Oxford University Press.
- Bittner, M. & K. Hale. 1996. The structural determination of case and agreement. *Linguistic Inquiry* 27: 1-68.
- Bjorkman, B.A.M. 2011. *BE-ing Default: The Morphosyntax of Auxiliaries*. Doctoral dissertation, MIT.
- Bobaljik, J.D. 1993. On Ergativity and Ergative Unergatives. In C.Phillips (ed.), *MIT Working Papers in Linguistics 19: Papers on Case and Agreement II*. Cambridge: MIT. 45-88.
- Boeckx, C. 2015. *Elementary Syntactic Structures. Prospects of a Feature-Free Syntax*. Cambridge: Cambridge University Press.
- Bok-Bennema, R. 1991. *Case and Agreement in Inuit*. Dordrecht: Foris.
- Borer, H. 2005a. *Structuring Sense, vol. I: In Name Only*. Oxford: Oxford University Press.
- Borer, H. 2005b. *Structuring Sense, vol. II: The Normal Course of Events*. Oxford: Oxford University Press.
- Bosque, I. 2009-2011. *Nueva Gramática de la Lengua Española*. Madrid: Espasa.
- Burzio, L. 1986. *Italian Syntax*. Dordrecht: Reidel.
- Caha, P. 2009. *The Nanosyntax of Case*. Doctoral dissertation. University of Tromsø.
- Caha, P. 2010. The Parameters of Case Marking and Spell Out Driven Movement. In J. Van Craenenbroeck (ed.), *Linguistic Variation Yearbook*. 32-77.
- Cardinaletti, A. & U. Shlonsky. 2004. Clitic Positions and Restructuring in Italian. *Linguistic Inquiry* 35-4: 519-557.
- Chomsky, N. 1970. Remarks on Nominalization. In R. Jacobs & P. Rosenbaum (eds.), *Readings in English Transformational Grammar*. Washington D.C.: Georgetown University Press.
- Chomsky, N. 1995. *The Minimalist Program*. Cambridge, Massachusetts: the MIT Press.
- Cinque, G. 1999. *Adverbs and Functional Heads. A Cross-linguistic Perspective*. New York: Oxford University Press.
- Cinque, G. 2004. Restructuring and Functional Heads. In A.Belletti (ed.), *Structures and Beyond. The Cartography of Syntactic Structures*, vol. 3. New York: Oxford University Press.

- Cinque, G. 2006. *Restructuring and Functional Heads. The Cartography of Syntactic Structures*, vol. 4. New York: Oxford University Press.
- Collins, C. 2005. A Smuggling Approach to the Passive in English. *Syntax* 8-2: 81-120.
- Comrie, B. 1976. *Aspect. An Introduction to the Study of Verbal Aspect and Related Problems*. Cambridge: Cambridge University Press.
- Comrie, B. 1985. *Tense*. Cambridge: Cambridge University Press.
- Coon, J. 2010. *Complementation in Chol (Mayan): a theory of split ergativity*. Doctoral dissertation. MIT.
- Coon, J., Mateo Pedro, P. & O. Preminger. 2015. The Role of Case in A-bar Extraction Asymmetries: Evidence from Mayan. *Linguistic Variation* 14-2: 179-242.
- Creissels, D. & C. Mounole, 2012. Non-canonical Valency Patterns in Basque, Variation and Evolution. *45th annual meeting of the Societas Linguistica Europaea*. Stockholm, 29-08/01-09-2012.
- Cuervo, M.C. *Datives at Large*. Doctoral dissertation. MIT.
- Davidson, D. 1967. The Logical Form of Action Sentences. In N.Rescher (ed.), *The Logic of Decision and Action*. Pittsburgh: University of Pittsburgh Press. Reprinted in Davidson 2006.
- Davidson, D. 2006. *The Essential Davidson*. Oxford: Oxford University Press.
- Déchaine, R-M. 1993. *Predicates Across-Categories: Towards a Category-Neutral Syntax*. Doctoral dissertation. University of Massachusetts, Amherst.
- Déchaine, R-M. 2005. Grammar at the Borderline: a Case Study of P as a Lexical Category. In J.Alderete et al. (eds.), *Proceedings of the 24<sup>th</sup> West Coast Conference on Formal Linguistics*. Somerville, MA: Cascadilla Proceeding Project.
- Déchaine, R-M. & M. Tremblay. In prep. Categories as Syntactic Objects. Ms., University of British Columbia & Queen's University.
- Demirdache, H. & M. Uribe-Etxebarria. 2000. The Primitives of Temporal Relations. In R.Martin, D.Michaels & J.Uriagereka (eds.), *Step by step. Essays on Minimalist syntax in honor of Howard Lasnik*. Cambridge, MA: the MIT Press. 157-186.
- Demirdache, H. & M. Uribe-Etxebarria. 2004. The Syntax of Time Adverbs. In J.Guéron & J.Lecarme (eds.), *The syntax of time*. Cambridge, MA: the MIT Press.

- Demirdache, H. & M. Uribe-Etxebarria. 2005. Aspect and Temporal Modification. In P.Kempchinsky & R.Slabakova (eds.), *Aspectual Inquiries*. 191-221. Dordrecht: Springer.
- Demirdache, H. & M. Uribe-Etxebarria. 2014. Aspect and Temporal Anaphora. *Natural Language and Linguistic Theory* 32: 855-895.
- Dixon, R.M.W. 1994. *Ergativity*. Cambridge: Cambridge University Press.
- Dowty, D.R. 1979. *Word Meaning and Montague Grammar. The Semantics of Verbs and Times in Generative Semantics and in Montague's PTQ*. Dordrecht: D. Reidel Publishing Company.
- Dowty, D.R. 1986. The Effect of Aspectual Classes on the Temporal Structure of Discourse: Semantics or Pragmatics. *Linguistics and Philosophy* 9: 37-61.
- Dowty, D.R. 1991. Thematic Proto-Roles and Argument Selection. *Language* 67: 547-619.
- Duguine, M. 2013. *Null Arguments and Linguistic Variation: a Minimalist Analysis of Pro-Drop*. Doctoral dissertation, University of the Basque Country (UPV/EHU) and Université de Nantes.
- Eguren, L. 2012. Predication Markers in Basque. In U.Etxebarria, R.Etxepare & M.Uribe-Etxebarria (eds.), *Noun Phrases and Nominalization in Basque: Syntax and Semantics*. John Benjamins Publishing Company. 243-266.
- Eguzkitza, A. 1997. Postposizioak euskal gramatikan. In I.Túrrer, A.Arejita, & C.Isasi (eds.), *Studia Philologica in Honorem Alfonso Irigoien*. Bilbao: University of Deusto. 83-88.
- Embick, D. 2000. Features, Syntax, and Categories in the Latin Perfect. *Linguistic Inquiry*, vol. 31-2: 185-230.
- Embick, D. 2004. On the Structure of Resultative Participles in English. *Linguistic Inquiry* 35-3: 355-392.
- Embick, D. & R. Noyer. 2007. Distributed Morphology and the Syntax/Morphology interface. In G.Ramchand & C.Reiss (eds.), *The Oxford Handbook of Linguistic Interfaces*. Oxford: Oxford University Press. 289-324.
- Etxebarria, U. 2014. Basque Nominals: from a System with Bare Nouns to a System without. In A.Aguilar-Guevara, B.Le Bruyn & J.Zwarts (eds.), *Weak Referentiality*. Amsterdam: John Benjamins. 335-364.
- Etxepare, R. 2003. Valency and Argument Structure in the Verb. In J. I. Hualde & J. Ortiz de Urbina (eds), *A grammar of Basque*. Berlin: Mouton de Gruyter. 369-465.

- Etxepare, R. 2013. Basque Primary Adpositions from a Clausal Perspective. *Catalan Journal of Linguistics* 12: 1-42.
- Etxepare, R. & B. Oyharçabal. 2012. Datives and Adpositions in North-Eastern Basque. In B.Fernández & R. Etxepare (eds.), *Datives in Variation: a Micro-Comparative Perspective*. Oxford: Oxford University Press.
- Etxepare, R. & Uribe-Etxebarria, M. 2012. Denominal Necessity Modals in Basque. In U. Etxebarria, R. Etxepare & M. Uribe-Etxebarria (eds), *Noun Phrases and Nominalizations in Basque: Syntax and Semantics*. Amsterdam/Philadelphia: John Benjamins. 283-330.
- Euskaltzaindia. 1991[1985]. *Euskal Gramatika. Lehen Urratsak I*. Nafarroa: Nafarroako Foru Elkargoa eta Euskaltzaindia.
- Euskaltzaindia. 1997[1987]. *Euskal Gramatikaren Lehen Urratsak II*. Nafarroa: Nafarroako Foru Elkargoa eta Euskaltzaindia.
- Euskaltzaindia. 2000. *Hiztegi Batua*. Bilbao: Euskaltzaindia.
- Fábregas, A. 2007. An Exhaustive Lexicalization Account of Directional Complements. In M.Bašić, M.Pantcheva, M.Son & P.Svenonius (eds.), *Tromsø Working Papers on Language & Linguistics: Nordlyd* 34.2, special issue on Space, Motion, and Result. CASTL, Tromsø.
- Fábregas, A. & R. Marin. 2012. Differentiating Eventivity from Dynamicity: the Aktionsart of Davidsonian State Verbs. *LSRL* 42, Southern Utah University. Cedar City, UT.
- Fernández, B. 1997. *Egiturazko kasuaren erkaketa euskaraz*. Doctoral dissertation. University of the Basque Country (UPV/EHU).
- Fernández, B. 2008. Quirky Dative Objects in Basque. Talk presented in the 3<sup>rd</sup> *European Dialect Syntax Meeting*. September 18-21, Venice.
- Fernández, B. & Ortiz de Urbina, J. 2010. *Datiboa hiztegian*. Bilbao: UPV/EHU.
- Fernández, B. & Ortiz de Urbina, J. 2012. Dative (First) Complements in Basque. In E.Carrilho & B.Fernández (eds.), *Syntactic microvariation in Westmost European Languages. Journal of Portuguese Linguistics* (Special Issue), 11-1. Edições Colibri - Unviersidade de Lisboa. 83-98.
- Fernández, B. & M. Rezac. 2010. Datibo osagarri bitxiak eta Datiboaren Lekualdatzea: ari nai diyot eta kanta egin nazu bidegurutzean. In B.Fernandez, P.Albizu & R.Etxepare (eds.), *Euskara eta euskarak: aldakortasun sintaktikoa aztergai*. Supplements of ASJU 52. University of the Basque Country (UPV/EHU). 113-149.

- Fernández, B. & M. Rezac. To appear. Differential Object Marking in Basque varieties. In B.Fernández & J.Ortiz de Urbina (eds.), *Microparameters in the Grammar of Basque*. Amsterdam: John Benjamins.
- Ferreira, M. 2005. *Event Quantification and Plurality*. Doctoral dissertation, MIT.
- Folli, R. & H. Harley. 2005. Flavors of v. In P.Kempchinsky & R.Slabakova (eds.), *Aspectual Inquiries*. Dordrecht: Springer. 95-120.
- Freeze, R. 1992. Existentials and Other Locatives. *Language* 68: 553-595.
- Galton, A. 1984. *The Logic of Aspect*. Oxford: Clarendon Press.
- Garzia, J. 2005. *Kalko Okerrak*. Ikasmaterialaren Aholku Batzordea, Estilo-liburuaren bigarren atala. Vitoria-Gasteiz: Eusko Jaurlaritzaren Argitalpen Zerbitzua.
- Gehrke, B. 2008. *Ps in Motion: On the Semantics and Syntax of P Elements and Motion Events*. Doctoral dissertation, Utrecht University, Utrecht.
- Giorgi, A. & F. Pianesi. 1997. *Tense and Aspect. From Semantics to Morphosyntax*. New York: Oxford University Press.
- Goenaga, P. 1985. Complementización y nominalización en euskara. *ASJU* 9-2: 495-570.
- Guimarães, M. 2000. In Defense of Vacuous Projections in Bare Phrase Structure. In M.Guimarães, L.Meroni, C.Rodrigues & I.San Martin (eds.), *University of Maryland Working Papers in Linguistics* 9: 90-115.
- Haddican, B. 2007. On *egin*: *do*-support and VP focus in Central and Western Basque. *Natural Language and Linguistic Theory* 25: 735-764.
- Haddican, B. & Tsoulas. 2012. A Continuum of Deficiency for Basque Infinitives. In U.Etxebarria, R.Etxepare & M.Uribe-Etxebarria (eds.), *Noun Phrases and Nominalization in Basque: Syntax and Semantics*. John Benjamins Publishing Company. 437-460.
- Hale, K. 1984. Notes on World View and Semantic Categories: Some Warlpiri Examples. In P.Muysken & H.van Riemsdijk (eds.), *Features and projections*. Dordrecht: Foris. 233-254.
- Hale, K. & S.J. Keyser.1993. On Argument Structure and the Lexical Expression of Syntactic Relations. In K. Hale and S.J. Keyser (eds.), *The View from Building 20*. Cambridge, Massachusetts: The MIT press. 53-109.
- Hale, K. & S.J. Keyser. 2002. *Prolegomenon to a Theory of Argument Structure*. Cambridge, Massachusetts: The MIT Press.
- Hale, K. & S.J. Keyser. 2005. *Aspect and the Syntax of Argument Structure*. In N. Erteschik-Shir & T. Rapoport (eds.), *The Syntax of Aspect: Deriving Thematic and Aspectual Interpretation*. New York: Oxford University Press.



- Halle, M. 1997. Distributed Morphology: Impoverishment and Fission. *MIT Working Papers in Linguistics* 30. 425-449.
- Halle, M. & A. Marantz. 1993. Distributed Morphology and the Pieces of Inflection. In K.Hale & S.J.Keyser (eds.), *The View From Building 20*. Cambridge: The MIT Press. 111-176.
- Halle, M. & A. Marantz. 1994. Some Key Features of Distributed Morphology. In A.Carnie & H.Harley (eds.), *MITWPL 21: Papers on phonology and morphology*. Cambridge: MITWPL. 275-288.
- Harley, H. 1995. *Subjects, Events and Licensing*. Doctoral dissertation. MIT.
- Harley, H. 2002. Possession and the Double Object Construction. In *Linguistic Variation Yearbook 2*: 29-68. Amsterdam: John Benjamins.
- Harley, H. 2005. How Do Verbs Get Their Names? Denominal Verbs, Manner Incorporation and the Ontology of Roots in English. In N.Erteschik-Shir & T.Rapoport (eds.), *The Syntax of Aspect*. New York: Oxford University Press. 42-64.
- Harley, H. 2013. External Argument and the Mirror Principle: On the Distinctness of Voice and v. *Lingua* 125: 34-57.
- Harley, H. & R. Noyer. 1999. State-of-the-art-article: Distributed Morphology. *GLOT International* 4 (4): 3-9.
- Hay, J., Kennedy, C. & B. Levin. 1999. Scalar Structure Underlies Telicity in "Degree Achievements". In T.Mathews & D.Strolovitch (eds.), *Proceedings of SALT 9, 1999*. Ithaca, NY: CLC Publications. 127-144.
- Heim, I. & A. Kratzer. 1998. *Semantics in Generative Grammar*. Malden: Blackwell.
- Herweg, M. 1991. Perfective and Imperfective Aspect in the Theory of Events and States. *Linguistics* 29: 969-1010.
- Holmer, A. 1999. An Active Analysis of Basque Ergativity. *Fontes Linguae Vasconum* 31: 189-225.
- Hualde, J.I. 2002. Regarding Basque Postpositions and Related Matters. In X.Arriagoitia, P.Goenaga & J.A.Lakarra (eds.), *Erramu Boneta. Festschrift for Rudolf P.G. De Rijk*. ASJU Supplements 44. Bilbao: University of the Basque Country (UPV/EHU). 325-340.
- Hualde, J.I. 2003a. Non-finite Forms. In J. I. Hualde & J. Ortiz de Urbina (eds), *A Grammar of Basque*. Berlin: Mouton de Gruyter. 202-210.
- Hualde, J.I. 2003b. Finite Forms. In J. I. Hualde & J. Ortiz de Urbina (eds), *A Grammar of Basque*. Berlin: Mouton de Gruyter. 211-252.

- Iatridou, S., Anagnostopoulou, E. & R. Izvorski. 2001. Observations About the Form and Meaning of the Perfect. In M.Kenstowicz (ed.), *Ken Hale: A Life in Language*. Cambridge, MA: the MIT Press. 189-238. Reprinted in Iatridou et al. 2003.
- Iatridou, Anagnostopoulou & Izvorski. 2003. Observations About the Form and Meaning of the Perfect. In A.Alexiadou, M.Rathert & A.von Stechow (eds.), *Perfect explorations*. Berlin/New York: Mouton de Gruyter. 153-204.
- Jackendoff, R. 1990. *Semantic Structures*. Cambridge, MA: the MIT Press.
- Jackendoff, R. 1991. Parts and Boundaries. In B. Levin and S. Pinker (eds.), *Lexical and Conceptual Semantics, Cognition Special Issue*. Cambridge, MA: Blackwell.
- Jackendoff, R. 1996. The Proper Treatment of Measuring Out, Telicity, and Perhaps Even Quantification in English. *Natural Language and Linguistic Theory* 14: 305-354.
- Jendraschek, G. 2014. Future Tense, Prospective Aspect, and Irrealis Mood as Part of the Situation Perspective: Insights from Basque, Turkish, and Papuan. In P.De Brabanter, M.Kissine & S.Sharifzadeh (eds.), *Future Times, Future Tenses*. Oxford: Oxford University Press.
- Jespersen, O. 1931. *A Modern English Grammar on Historical Principles, Book IV, Syntax*. London: George Allen and Unwin.
- Johns, A. 1992. Deriving Ergativity. *Linguistic Inquiry* 27: 57-87.
- Katz, G. 1995. *Stativity, Genericity, and Temporal Reference*. Doctoral dissertation, University of Rochester, New York.
- Katz, G. 2003. On the Stativity of the English Perfect. In A.Alexiadou, M.Rathert & A.von Stechow (eds.), *Perfect Explorations*. Berlin/New York: Mouton de Gruyter. 205-234.
- Katz, G. 2010. Habituals, Stativity and Detecting Habituality. Talk presented in the Workshop *Disposition, Abilities and States*. Paris, June 24-25.
- Kayne, R.S. 1993. Towards a Modular Theory of Auxiliary Selection. *Studia Linguistica* 47-1: 3-31.
- Kayne, R.S. 1994. *The Antisymmetry of Syntax*. Cambridge, MA: the MIT Press.
- Kayne, R.S. 2000. *Parameters and Universals*. New York: Oxford University Press.
- Kayne, R.S. 2004. Prepositions as Probes. In A.Belletti (ed.), *Structures and Beyond. The Cartography of Syntactic Structures*, vol. 3. New York: Oxford University Press.

- Kayne, R.S. 2008. Antisymmetry and the Lexicon. *Linguistic Variation Yearbook* 8: 1-31.
- Kennedy, C. & B. Levin. 2001. Telicity Corresponds to Degree of Change. Seminar presentation, Stanford University.
- Kennedy, C. & L. McNally. 1999. From Event Structure to Scale Structure: Degree Modification in Deverbal Adjectives. In T.Mathews & D.Strolovitch (eds.), *The Proceedings of SALT IX, 1999*. Ithaka, NY: CLC Publications. 163-180.
- Kennedy, C. & L. McNally. 2005. Scale Structure, Degree Modification, and the Semantics of Gradable Predicates. *Language* 81: 345-381.
- Kim, J. 1969. Events and their Descriptions: Some Considerations. In N.Rescher (ed.), *Essays in Honor of Carl G. Hempel*. Dordrecht: Reidel. 198-215.
- Kim, J. 1976. Events as Property Exemplifications. In M.Brand & D.Walton (eds.), *Action Theory. Proceedings of the Winnipeg Conference on Human Action*. Dordrecht: Reidel. 159-177.
- Klein, W. 1995. A Time-Relational Analysis of Russian Aspect. *Language* 71: 669-695.
- Kiparsky, P. 2005. Blocking and Periphrasis in Inflectional Paradigms. In G.E.Booij & J.van Marie (eds.), *Yearbook of Morphology 2004*. Dordrecht: Springer. 113-135.
- Koopman, H. & D. Sportiche. 1991. The Position of Subjects. *Lingua* 85: 211-258.
- Kratzer, A. 1994. The Event Argument and the Semantics of Voice. Ms., University of Massachusetts at Amherst.
- Kratzer, A. 1996. Severing the External Argument from its Verb. In J.Roorych & L.Zaring (eds.), *Phrase Structure and the Lexicon*. Studies in natural language and linguistic theory, vol.33. Dordrecht: Kluwer Academic Publishers. 109-137.
- Kratzer, A. 1998. More Structural Analogies Between Pronouns and Tenses. *Proceedings of SALT VIII*. Ithaka, NY: CLC. 92-110.
- Kratzer, A. 2000. Building Statives. *Berkeley Linguistic Society* 26. 385-399.
- Krifka, M. 1989. Nominal Reference, Temporal Constitution and Quantification in Event Semantics. In R.Bartsch, J.van Benthem & P.van Emde Boas (eds.), *Semantics and Contextual Expression*. Standford, CA: CSLI Publications. 75-115.
- Krifka, M. 1998. The Origins of Telicity. In S.Rothstein (ed.), *Events and grammar*. Dordrecht: Kluwer. 197-235.
- Kuroda, Y. 1988. Whether We Agree or Not. A Comparative Syntax of English and Japanese. *Linguisticae Investigationes* 12:1-47.

- Lafon, R. 1972. Le suffixe *-ke*, *-te* dans la conjugaison basque (suite et fin). *BSL* LXVII-1, 239-265. Reprinted in Lafon 1999.
- Lafon, R. 1999. Le suffixe *-ke*, *-te* dans la conjugaison basque (suite et fin). In J.Haritschelhar & P.Charritton (eds.), *Vasconiana*. Iker 11. Bilbao: Euskaltzaindia. 505-528.
- Laka, I. 1993a. Unergatives that Assign Ergative, Unaccusatives that Assign Accusative. In J.D.Bobaljik & C.Phillips (eds.), *Papers on Case and Agreement I*, MITWPL 18. Cambridge, MA: MITWPL. 149-172.
- Laka, I. 1993b. The Structure of Inflection: a Case Study in X<sup>o</sup> Syntax. In J.I. Hualde & J. Ortiz de Urbina (eds.), *Generative Studies in Basque Linguistics*. Current Issues in Linguistic Theory. John Benjamins Publishing Company. 21-70.
- Laka, I. 2004. Ari progresiboaz: euskararen kasu markak. In P.Albizu & B.Fernández, (eds.), *Euskal Gramatika XXI. mendearen atarian: arazo zaharrak, azterbide berriak*. Bilbao: UPV/EHUko argitalpen zerbitzua.
- Laka, I. 2006a. Deriving Split Ergativity in the Progressive: the Case of Basque. In A. Johns, D.Massam & J.Ndayiragije (eds.), *Ergativity: Emerging Issues*. Dordrecht/Berlin: Springer, pp.173-195.
- Laka, I. 2006b. On the Nature of Case in Basque: Structural or Inherent?. In H.Broekhuis, N. Corver, J.Koster, R.Huybregts & U.Kleinhenz (eds.), *Organizing Grammar*. Berling: Mouton de Gruyter. 374-382.
- Lakoff, G. 1965. *On the Nature of Syntactic Irregularity*. Doctoral dissertation, Indiana University.
- Lakusta, L. 2005. *Source and Goal Asymmetry in Non-linguistic Motion Event Representations*. Doctoral dissertation. Johns Hopkins University, Maryland.
- Lakusta, L. & B. Landau. 2005. Starting at the End: The Importance of Goals in Spatial Language. *Cognition* 96: 1-33.
- Landman, F. & S. Rothstein. 2012a. The Felicity of Aspectual *for*-phrases, part 1: Homogeneity. *Language and Linguistic Compass* 6-2: 85-96.
- Landman, F. & S. Rothstein. 2012b. The Felicity of Aspectual *for*-phrases, part 2: Incremental Homogeneity. *Language and Linguistic Compass* 6-2: 97-112.
- Larson, R. 1988. On the Double-Object Construction. *Linguistic Inquiry* 19: 335-391.
- Legate, J.A. 2002. *Walpiri: Theoretical Implications*. Doctoral dissertation, MIT.
- Legate, J.A. 2008. Morphological and Abstract Case. *Linguistic Inquiry* 39-1: 55-101.
- Legate, J.A. 2014. *Voice and v. Lessons from Acehnese*. *Linguistic Inquiry Monograph*, vol. 69. The MIT Press.
- Levin, B. 1983. *On the Nature of Ergativity*. Doctoral Dissertation, MIT.

- Levin, B. 1993. *English Verb Classes and Alternations: A Preliminary Investigation*. Chicago, Ill.: University of Chicago Press.
- Levin, B. 1999. Objecthood: An Event Structure Perspective. *Proceedings of the CLS 35, vol. 1: The Main Session*. Chicago Linguistic Society, University of Chicago. Chicago, IL. 223-247.
- Levin, B. & M. Rappaport Hovav. 1995. *Unaccusativity. At the Syntax-Lexical Semantic Interface*. Cambridge, MA: the MIT Press.
- Levinson, L. 2011. Possessive WITH in Germanic: HAVE and the Role of P. *Syntax* 14-4: 355-393.
- Löbner, S. 1988. Ansätze zu einer integralen semantischen Theorie von Tempus, Aspekt, und Aktionsarten. In V.Ehrich & H.Vater (eds.), *Temporalsemantik. Beiträge zur Linguistik der Zeitreferenz*. Tübingen: Niemeyer.
- Lyons, J. 1977. *Semantics*. Cambridge: Cambridge University Press.
- Mahajan, A. 1994. The Ergativity Parameter: Have-be Alternation, Word Order and Split Ergativity. *Proceedings of NELS 24*. Amherst: GLSA. 317-331.
- Maienborn, C. 2005. On the Limits of the Davidsonian Approach: The Case of Copula Sentences. *Theoretical Linguistics* 31 (3), 275-316.
- Maienborn, C. 2007. On Davidsonian and Kimian states. In I.Comorovski & K.von Heusinger (eds.), *Existence: syntax and semantics*. Springer. 107-130.
- Massam, D. 2002. Fully Internal Case: Surface Ergativity can be profound. In A.Rackowski & N.Richards (eds.), *Proceedings of AFLA 8: The Eight Meeting of the Austronesian Formal Linguistic Association. MITWPL 44*. 185-196.
- Mateu, J. & L. Amadas. 1999. Extended Argument Structure: Progressive as Unaccusative. *Catalan Working Papers in Linguistics 7*: 159-174.
- Mateu, J. 2002. *Argument structure: relational construal at the syntax-semantic interface*. Doctoral dissertation. Universitat Auntonoma de Barcelona.
- Mateu, J. 2012. Conflation and Incorporation Processes in Resultative Constructions. In V.Demonte & L.McNally (eds.), *Telicity, Change and State: a Cross-Categorial View of Event Structure*. New York: Oxford University Press.
- Mateu, J. & G. Rigau. 2002. A Minimalist Account of Conflation Processes. Parametric Variation at the Lexicon-Syntax Interface. In A.Alexiadou (ed.), *Theoretical Approaches to Universals*. Amsterdam/Philadelphia: John Benjamins.
- Marantz, A. 1991. Case and Licensing. In G.Westphal, B.Ao & H.-R.Chae (eds.), *Proceedings of ESCOL 91*, Cornell University. Ithaka, NY: Cornell University Linguistics Club. 234-253.

- Marantz, A. 1997. No Escape from Syntax: Don't Try Morphological Analysis in the Privacy of Your Own Lexicon. *University of Pennsylvania Working Papers in Linguistics*, vol. 4-2.
- Marantz, A. 2001. Words. WCCFL XX Handout, USC, February 2001.
- Marantz, A. 2007. Phases and Words. In S.-H. Choe (ed.), *Phases in the Theory of Grammar*. Seoul: Dong In. 191-222.
- McCawley, J.D. 1968. Lexical Insertion in a Transformational Grammar without Deep Structure, *CLS* 4: 71-80.
- McFadden, T. 2004. *The Position of Morphological Case in the Derivation: a Study on the Syntax-Morphology Interface*. Doctoral dissertation, University of Pennsylvania.
- McIntyre, A. 2004. Event Paths, Conflation, Argument Structure, and VP Shells. *Linguistics* 42-3: 523-571.
- Mitxelena, K. 1981[2011]. Lengua común y dialectos vascos. In J.A.Lakarra & I.Ruiz Arzallus (eds.), *Luis Michelena. Obras Completas VII. Fonética y Fonología, Morfosintaxis y Dialectología*. University of the Basque Country (UPV/EHU) and Gipuzkoako Foru Aldundia. 517-543.
- Mitxelena, K. 1989. *Euskal Idazlan guztiak I, Klasikoak*. Euskal Editorren Elkarte.
- Mitxelena, K. 1977[2011]. Notas sobre compuestos verbales vascos. In J.A.Lakarra & I.Ruiz Arzallus (eds.), *Luis Michelena. Obras Completas VII. Fonética y Fonología, Morfosintaxis y Dialectología*. University of the Basque Country (UPV/EHU) and Gipuzkoako Foru Aldundia. 269-300.
- Mounole, C. 2011. *Le verbe basque ancien: étude philologique et diachronique*. Doctoral dissertation, University of the Basque Country (UPV/EHU) and Université Michel de Montaigne-Bordeaux III.
- Mujika, J.A. 2008. Adlatiboaren berbalizazioaz. In X.Arriagoitia & J.A.Lakarra (eds.), *Gramatika Jaietan: Patxi Goenagaren omenez, ASJU*. Bilbao: Gipuzkoako Foru Aldundia and University of the Basque Country (UPV/EHU).
- Nash, L. 1994. On BE and HAVE in Georgian. In H.Harley & C.Phillips (eds.), *MITWPL 22: The Morphology-Syntax Connection*. Cambridge, MA: MITWPL.
- Nash, L. 1996. The Internal Ergative Subject Hypothesis. *Proceedings of NELS* 26: 195-210.
- Odria, A. 2014. Differential Object Marking and the Nature of Dative Case in Basque Varieties. *Linguistic Variation* 14-2: 289-317. Amsterdam/Philadelphia: John Benjamins.

- Odria, A. forthcoming. *Differential Object Marking in Basque Syntax. A Microcomparative Survey*. Doctoral dissertation, University of the Basque Country (UPV/EHU).
- Odria, A. & A. Berro. 2011. Subject and Object Marking Alternation in Bivalent Predicates: Dialectal Evidence from Basque. Talk presented in *Typology and Variation: New Trends in syntactic research*. Helsinki.
- Ortiz de Urbina, J. 1989. *Parameters in the Grammar of Basque. Studies in Generative Grammar 33*. Dordrecht: Foris Publications.
- Ortiz de Urbina, J. & M. Uribe-Etxebarria. 1991. Participial Predication in Basque. *Supplements of ASJU 14-2*. 993-1012.
- Oyharçabal, B. 1987. *Etude descriptive de constructions complexes en basque: Propositions relatives, temporelles, conditionnelles et concessives*. Doctoral dissertation. Paris 7.
- Oyharçabal, B. 1992. Structural and Inherent Case-Marking; Ergaccusativity in Basque. In J.A.Lakarra & J.Ortiz de Urbina (eds), *Syntactic Theory and Basque Syntax*. *Supplements of ASJU 27*. Donostia: UPV/EHU and Gipuzkoako Foru Aldundia. 309-342.
- Oyharçabal, B. 2003. Lexical Causatives and Causative Alternation in Basque. In B.Oyharçabal (ed.), *Inquiries into the Syntax-Lexicon Relations in Basque*. *Supplements of ASJU 46*: 223-253.
- Oyharçabal, B. 2006. Basque Light Verb Constructions. *ASJU 40*: 787-806.
- Pancheva, R. 2003. The Aspectual Makeup of Perfect Participles and the Interpretation of the Perfect. In A.Alexiadou, M.Rathert & A.von Stechow (eds.), *Perfect explorations*. Berlin/New York: Mouton de Gruyter. 277-306.
- Pancheva, M.B. 2011. *Decomposing Path. The Nanosyntax of Directional Expressions*. Doctoral dissertation, University of Tromsø, CASTL.
- Parsons, T. 1990. *Events in the Semantics of English*. Cambridge, MA: the MIT Press.
- Perlmutter, D.M. 1978. Impersonal Passives and the Unaccusative Hypothesis. *Proceedings of the 4<sup>th</sup> Annual Meeting of the Berkeley Linguistics Society*. 157-190.
- Perlmutter, D.M. & P.M. Postal. 1984. The I-advancement Exclusiveness Law. In D.M. Perlmutter and C.Rosen (eds.), *Studies in relational grammar 2*. Chicago: University of Chicago Press. 81-125.
- Pietroski. 2005. *Events and Semantic architecture*. Oxford: Oxford University Press.

- Pineda, Ana. 2014. *Les fronteres de la (in)transitivitat. Estudi dels aplicatius en llengües romàniques i basc*. Doctoral dissertation, Universitat Autònoma de Barcelona.
- Piñón, C. 1993. Paths and Their Names. In K.Beals et al. (eds.), *Chicago Linguistics Society 29-2*. Chicago: Chicago Linguistics Society. 287-303.
- Preminger, O. 2012. The Absence of an Implicit Object in Unergatives: New and Old Evidence from Basque. *Lingua* 122(3): 278-288.
- Pylkkänen, L. 2002. *Introducing Arguments*. Doctoral dissertation, MIT.
- Pylkkänen, L. 2008. *Introducing Arguments. Linguistic Inquiry Monograph*, vol. 49. The MIT Press.
- Pustejovsky, J. 1991. The Syntax of Event Structure. *Cognition* 41: 47-81.
- Ramchand, G. 2004. First Phase Syntax. Draft of the *Workshop on Tense, Aspect and Modality* at GLOW. Thessaloniki.
- Ramchand, G. 2008a. *Verb Meaning and the Lexicon: A First Phase Syntax*. Cambridge: Cambridge University Press.
- Ramchand, G. 2008b. Lexical Items in Complex Predications: Selection as Underassociation. In P.Svenonius & I.Tolskaya (eds.), *Tromsø working papers on language & linguistics: Nordlyd 35*, special issue on Complex Predication. 115-141.
- Rappaport Hovav, M. & B. Levin. 2000. Classifying Single Argument Verbs. In P.Coopmans, M.Everaert & J.Grimshaw (eds.), *Lexical Specification and Insertion*. Amsterdam/Philadelphia: John Benjamins.
- Rebuschi, G. 1984. *Structure de l'énoncé en basque*. Paris: SELAF.
- Reichenbach, H. 1947. *Elements of Symbolic Logic*. New York: the Free Press.
- Reinhart, T. 1997. Strategies of Anaphora Resolution. *OTS Working Papers*, TL97-007.
- Reinhart, T. 2002. The Theta System: an Overview. *Theoretical Linguistics* 28: 229-290.
- Rezac, M., P. Albizu & R. Etxepare. 2014. The structural Ergative of Basque and the Theory of Case. *Natural Language and Linguistic Theory* 32: 1273-1330.
- van Riemsdijk, H. & Huijbregts, R. 2002. Location and Locality. In M. van Oostendorp & E. Anagnostopoulou (eds.), *Progress in Grammar: Articles at the 20th Anniversary of the Comparison of Grammatical Models Group in Tilburg*. Amsterdam: Meertens Instituut.1-23.
- de Rijk, R.P.G. 2008. *Standard Basque. A Progressive Grammar*. Cambridge/London: The MIT Press.



- Ritter, E. & S. Rosen. 1998. Delimiting Events in Syntax. In M. Butt & W. Geuder (eds.), *The Projection of Arguments*. Stanford, California: CSLI. 135-164.
- Rothmayr, A. 2009. *The Structure of Stative Verbs*. Amsterdam/Philadelphia: John Benjamins.
- Salaburu, P. 1992. Euskara, hizkuntza ergatiboa ote da? In J.H. Duhalde (ed.), *Luis Villasanteri omenaldia*. Bilbao: Euskaltzaindia. 417-433.
- Salaburu, P., Goenaga, P. & I. Sarasola. 2008-2010. *Basque Grammar Online (Sareko Euskal Gramatika)*. Basque Language Institute. University of the Basque Country (UPV/EHU).
- Salanova, A.P. 2007. *Nominalization and Aspect*. Doctoral dissertation. MIT.
- San Martin, I. 2004. *On Subordination and the Distribution of PRO*. Doctoral dissertation. University of Maryland.
- Sarasola, I. 1977. Sobre la bipartición inicial en el análisis en constituyentes, *ASJU*, XI: 51-90.
- Schwarzschild, R. 2002. The Grammar of Measurement. In B. Jackson (ed.), *Proceedings of SALT 12*. Ithaca, NY: CLC Publications.
- Smith, C.S. 1997[1991]. *The Parameter of Aspect*. Studies in Linguistics and Philosophy. Dordrecht: Kluwer Academic Publishers.
- Sorace, A. 2000. Gradients in Auxiliary Selection with Intransitive Verbs. *Language* 76: 859-890.
- Sorace, A.. 2004. Gradience at the Lexicon-Syntax Interface: Evidence from Auxiliary Selection. In A. Alexiadou, M. Everaert & E. Anagnostopoulou (eds.), *The Unaccusativity Puzzle*. Oxford: Oxford University Press. 243-268.
- Speas, M. 1986. *Adjunctions and Projections in Syntax*. Doctoral dissertation, MIT.
- Starke, M. 2009. Nanosyntax. A Short Primer to a New Approach to Language. In P. Svenonius, G. Ramchand, M. Starke & K.T. Taraldsen (eds.), *Nordlyd* 36.1, special issue on Nanosyntax. CASTL, Tromsø.
- Starke, M. 2014. Towards Elegant Parameters: Language Variation Reduces to the Size of Lexically-Stored Trees. In M.C. Picallo (ed.), *Linguistic Variation in the Minimalist Framework*. Oxford: Oxford University Press.
- Stowel, T. 1993. The Syntax of Tense. Ms., University of California, Los Angeles.
- Stowel, T. 2007. The Syntactic Expression of Tense. *Lingua* 117: 437-463.
- Svenonius, P. 2006. The Emergence of Axial Parts. In P. Svenonius (ed.), *Tromsø Working Papers on Language and Linguistics: Nordlyd* 33.1, special issue on Adpositions. Tromsø: University of Tromsø.

- Svenonius, P. 2007. Adpositions, Particles and the Arguments They Introduce. In K.S.T.Bhattacharya & E.Reuland (eds.), *Argument Structure*. Amsterdam: John Benjamins Publishing Company. 63-103.
- Svenonius, P. 2008. Spatial P in English. In G. Cinque & L. Rizzi (eds.), *The Cartography of Syntactic Structures* vol. 6. New York: Oxford University Press.
- Talmy, L.D. 2000. *Toward a Cognitive Semantics*, vol II. Cambridge, Massachusetts: the MIT Press.
- Taraldsen, K.T. 2010. The Nanosyntax of Nguni noun class Prefixes and ConCORDS. *Lingua* 120: 1522-1548.
- Torrego, E. 2012. The Unaccusative Case Pattern of Hindi and Auxiliary *be*. *Lingua* 122-3: 215-224.
- Travis, L.M. 1984. *Parameters and Effects of Word Order Variation*. Doctoral dissertation, MIT.
- Travis, L.M. 2000. The L-syntax/S-syntax Boundary: Evidence from Austronesian. In I.Paul, V.Phillips & L.Travis (eds.), *Formal issues in Austronesian linguistics*. Dordrecht: Springer. 167-194.
- Travis, L.M. 2005. Articulated vPs and the Computation of Aspectual Classes. In P.Kempchinsky & R.Slabakova (eds.), *Aspectual Inquiries*. 69-94. Dordrecht: Springer.
- Travis, L.D. 2010. *Inner Aspect. The articulation of vP*. Dordrecht: Springer.
- Uribe-Etxebarria, M. 1989. Some Notes on the Structure of IP in Basque. Ms. UConn, Storrs.
- Uribe-Etxebarria, M. 2014. Asymmetries in the Long Distance Reading of Temporal Clauses. *Hizkuntzalartiza Mintegia / Seminario Lingüística*. January 31<sup>st</sup>. Vitoria-Gasteiz. University of the Basque Country (UPV/EHU).
- Vendler, Z. 1957. Verbs and Times. *The Philosophical Review*, 66-2, 143-160. Reprinted in Vendler 1967.
- Vendler, Z. 1967. *Linguistics in Philosophy*. Ithaca, NY: Cornell University Press. 97-121.
- Verkuyl, H.J. 1993. *A theory of Aspectuality: the Interaction Between Temporal and Atemporal Structure*. Cambridge: Cambridge University Press.
- Vlach, F. 1981. The Semantics of the Progressive. In P.Tedeschi & A.Zaenen (eds.), *Syntax and Semantics, vol. 14: Tense and Aspect*. New York: Academic Press. 271-292.
- Vlach, F. 1993. Temporal Adverbials, Tenses and the Perfect. *Linguistics and Philosophy* 16: 231-283.

- Wechsler, S. Resultatives Under the ‘Event-Argument Homomorphism’ Model of Telicity. In N.Erteschik-Shir & T.Rapoport (eds.), *The Syntax of Aspect*. Oxford: Oxford University Press.
- Woolford, E. 2006. Lexical Case, Inherent Case, and Argument Structure. *Linguistic Inquiry* 37.1: 111-130.
- Yamaguchi, K. 2004. *A Typological, Historical and Functional Study of Adpositions in the Languages of the World*. Doctoral dissertation, University of Albuquerque.
- Zabala, I. 1993. *Predikazioaren teoriak gramatika sortzailean (euskararen kasua)*. Doctoral Dissertation, University of the Basque Country (UPV/EHU).
- Zabala, I. 2004. Los predicados complejos en vasco. In I.Zabala, E.Pérez Gaztelu & L.Gràcia Sole (coord.), *Las fronteras de la composición en lenguas románicas y en vasco*. Bilbao: Deustuko Unibertsitatea, Argitalpen Zerbitzua.
- Zagona, K. 1990. Times as Temporal Argument Structure. Ms., University of Washington, Seattle.
- Zagona, K. 2005. The spatio-temporal Path and Aspectual Composition. In P.Kempchinsky & R.Slabakova (eds.), *Aspectual Inquiries*. Dordrecht: Springer. 171-190.
- Zuazo, K. 2008. *Euskalkiak. Euskararen dialektoak*. Donostia: Elkar.
- Zubizarreta, M.L. & E. Oh. 2007. *On the Syntactic Composition of Manner and Motion*. Cambridge, MA: MIT Press.
- Zwart. 2005. Prepositional Aspect and the Algebra of Pahts. *Linguistics and Philosophy* 28: 739-779.

### Corpus:

- Landa, J. 2008. *Corsyntax*. Ametzagaña. [<http://weblingua.ametza.com/cgi-bin/corsyntax/bila.pl?k=&c=libuHego&l=abisatu>]
- Mitxelena, K. & I. Sarasola. 1989-2005. *General Basque Dictionary (Orotariko Euskal Hiztegia)*. Bilbao: Euskaltzaindia. [[http://www.euskaltzaindia.eus/index.php?option=com\\_content&view=article&id=276&Itemid=413&lang=eu](http://www.euskaltzaindia.eus/index.php?option=com_content&view=article&id=276&Itemid=413&lang=eu)]
- Sarasola, I. in progress. *Dictionary of Contemporary Basque (Egungo Euskararen Hiztegia)*. Basque Language Institute. UPV/EHU. [<http://www.ehu.eus/en/web/eins/egungo-euskararen-hiztegia-eeh->]

- Sarasola, I., Salaburu, P. & J. Landa. 2009. *Contemporary Dynamic Prose (Ereduzko Prosa Dinamikoa)*. Basque Language Institute. UPV/EHU. [<http://www.ehu.eus/en/web/eins/ereduzko-prosa-dinamikoa-epd->]
- Sarasola, I., Salaburu, P. & J. Landa. 2011. *Corpus Goenkale (Goenkale Corpusa)*. Basque Language Institute. [<http://www.ehu.eus/en/web/eins/goenkale-corpusa>]
- Sarasola, I., Salaburu, P., Landa, J. & J. Zabaleta. 2011. *Contemporary Reference Prose (Ereduzko Prosa Gaur)*. Basque Language Institute. UPV/EHU. [<http://www.ehu.eus/en/web/eins/ereduzko-prosa-gaur-epg->]



## Abbreviations

|        |                                    |
|--------|------------------------------------|
| ABS    | absolutive case or agreement       |
| ALL    | allative                           |
| APPROX | approximative                      |
| COMP   | comparative                        |
| CMP    | complementizer                     |
| DAT    | dative case or agreement           |
| DEST   | destinative                        |
| ERG    | ergative case or agreement         |
| GEN    | genitive                           |
| INE    | inessive                           |
| INF    | infinitive                         |
| INSTR  | instrumental                       |
| KA     | <i>-ka</i> morpheme (Basque)       |
| MOT    | motivative                         |
| PART   | partitive                          |
| pl     | plural                             |
| PST    | past tense                         |
| SE     | <i>se</i> clitic (Spanish)         |
| sg     | singular                           |
| SOC    | sociative                          |
| SUP    | superlative                        |
| TERM   | terminative                        |
| TU     | <i>-tu/-i/-n</i> morpheme (Basque) |
| TZE    | <i>-t(z)e</i> morpheme (Basque)    |

